

“MULTICONTROL FUNCTIONAL STATIC SYNCHRONOUS COMPENSATOR (STATCOM) IN POWER SYSTEM STEADY STATE OPERATION”

^[1]Pratiksha Deshmukh, ^[2]Dr.A.S.Telang

^[1]ME scholar,Electrical Engineering,P.R.Pote College of Engineering and Management,Amravati.

^[2]Assistant Professor, Electrical Engineering,P.R.Pote College of Engineering and Management,Amravati.

Abstract

The development of the modern power system has led to an increasing complexity in the study of power flow operation and also presents new challenges to system stability. Stability plays a significant role in ensuring the stable operation of power system with continuous power flow operation without any limitations. Flexible alternating current transmission system (FACTS) is an application of a power electronics devices which is used to control the power flow and to improve the power system stability. From family of FACTs devices, STATCOM is one of the recently developed converter based Flexible Alternating Current Transmission System controller which has the ability to control all parameters of power system such as voltage, impedance and phase angle. The study of steady state model of STATCOM is carried out here by the use of Newton-Raphson power flow. Multi-control functional model of a STATCOM for power system steady state operation is studied and discussed and standard IEEE bus test systems are used to illustrate the multi-control functional model of a STATCOM, voltage control specifically. The model is simulated by using MATLAB software.

I.Introduction

The gap between the generation and consumer demand due to continuous increasing load affects on the quality of power system stability and load voltage which may influence on the sensitive electronic equipments.due to the variable load, voltage sag and swell are created at the distribution side. The sensitive electronic equipment's have to be tolerated to operate within its limitation. Also change in demand will give the system towards instability. Hence it is necessary to give the reliable continuous operation by the utility with good power quality. In order to make system reliable with quality of power, different FACTS controllers are developed. The STATCOM is the one of most powerful FACTS device from the family of FACTS devices The static compensator (STATCOM) is one of the most prominent members in the family of flexible AC transmission system (FACTS) devices, plays important role in improving system stability. It is connected in shunt to the transmission grid. Its basic purpose is to provide voltage support to the transmission/ distribution grid through controlled reactive power injection. However, apart from the voltage support, it is also used to provide damping to the transmission grid for enhancing the stability of the system.

The STATCOM is the shunt FACTS devices based on voltage source converter (VSC). The principal advantages of shunt capacitors are their low cost and flexibility of installation and operation. The steady state model of STATCOM is first studied for its implementation in the Newton-Raphson power flow and an attempt has been made to address one of the control function of the STATCOM in power system steady state operation.

II.STATCOM

The Static Synchronous Compensator (STATCOM) is a shunt device of the Flexible AC Transmission Systems (FACTS) family using power electronics to control power flow and improve transient stability on power grids.The STATCOM regulates voltage at its terminal by controlling the amount of reactive power injected into or absorbed from the power system. When system voltage is low, the STATCOM generates reactive power

(STATCOM capacitive). When system voltage is high, it absorbs reactive power (STATCOM inductive). In steady state operation, the voltage V_2 generated by the VSC is in phase with V_1 ($\delta=0$), so that only reactive power is flowing ($P=0$). If V_2 is lower than V_1 , Q is flowing from V_1 to V_2 (STATCOM is absorbing reactive power). On the reverse, if V_2 is higher than V_1 , Q is flowing from V_2 to V_1 (STATCOM is generating reactive power). A capacitor connected on the DC side of the VSC acts as a DC voltage source. In steady state the voltage V_2 has to be phase shifted slightly behind V_1 in order to compensate for transformer and VSC losses and to keep the capacitor charged. Two VSC technologies can be used for the VSC.

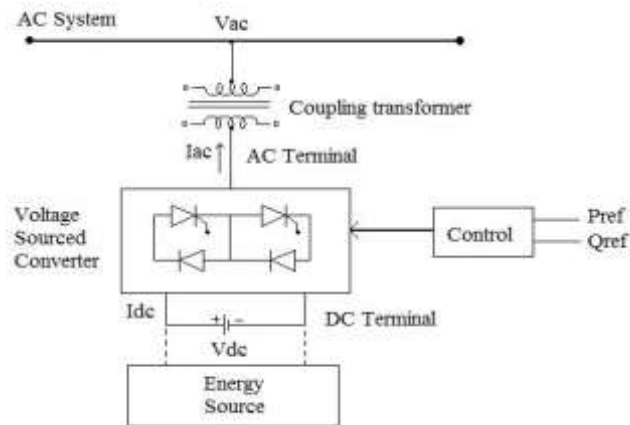

Fig 1. Basic structure of STATCOM

III. Literature Review

The flexible ac transmission system (FACTS) is a new technology, based on power electronics, to enhance power system capability through the ability of high-speed electronic control of ac transmission line parameters [1]. The STATCOM is the one of most powerful FACTS device from the family of FACTS devices [2]. Power system stability is defined as that property of a power system that enables it to remain in a state of operating equilibrium under normal operating conditions and to regain an acceptable state of equilibrium after being subjected to a disturbances [3]. The static compensator (STATCOM) is one of the most prominent members in the family of flexible AC transmission system (FACTS) devices, plays important role in improving system stability. It is connected in shunt to the transmission grid. Its basic purpose is to provide voltage support to the transmission/ distribution grid through controlled reactive power injection. However, apart from the voltage support, it is also used to provide damping to the transmission grid for enhancing the stability of the system [4]. The concept of using solid state, power electronic converters for power flow control at the transmission level has been known as FACTS [5]. A faster solution is obtained using the Newton- Raphson method and is suitable for large-scale problems. In this approach, the partial derivatives are used to construct the Jacobian matrix solution. The Newton-Raphson solution approach is much faster than the other approaches.[6]. Y. Zhang, B. Wu and J. Zhou, provides detail description related Newton Raphson power flow algorithm [7]. Enrique Acha presents an approach for FACTS Modelling [8]. References [9-11] discuss about the concept of STATCOM modeling. The output voltage of a STATCOM is controlled such that it provides the requisite amount of reactive power compensation to any system bus to which it is connected [12]. Suman Bhowmick, Biswarup Das and Narendra kumar, present an approach for STATCOM model for power flow analysis as well power flow equations in proposed STATCOM model [13]. The performance of 30 bus system with and without STATCOM discuss in reference [14]. References [15-22] discuss about the concept of power flow model, controllers etc and discuss about the voltage stability improvement in power system.

IV. Problem definition

The power flow problem is formulated as a set of nonlinear equations. Many calculation methods have been proposed to solve this problem. Among them, Newton-Raphson which is considered as the state of the art power-flow technique adopted for industry applications. The main advantage of the Newton Raphson method is its quadratic rate of convergence, which is faster than any other power-flow method. NR power flow equations given by

$$Q_i = \sum_{k=1}^n V_i V_k Y_{ik} \sin(\delta_i - \delta_k - \theta_{ik}) \quad P_i = \sum_{k=1}^n V_i V_k Y_{ik} \cos(\delta_i - \delta_k - \theta_{ik})$$

V.PROPOSED SOLUTION

The study of steady state model of the STATCOM for NR load flow analysis and one of the control function of the STATCOM. To incorporate STATCOM for steady state operation in power system, following methodology will be adapted.

1. Study load flow using Newton Raphson load flow analysis.
2. Study of STATCOM and its Steady State power flow model.
3. Implementation of steady state model of STATCOM in NR load flow method.
4. Multi-control functions (9 controls) of STATCOM, out of which the control function which is mostly related to the stability will be under consideration and hence will be investigated on standard IEEE bus test systems.

Conclusion:

In this project, STATCOM is used to control the power flow in transmission line. From fact family, STATCOM is custom power device which has many advantages such as low cost, fast control. It has many multicontrol function which has steady state operation in power system. There are two solutions associated with current magnitude control. Alternative formulations of control functions are proposed in this paper. The reactive power flow and apperent power control functions which may be used in either normal control or security control of electric power systems, are interesting and attractive. Numerical results based on IEEE 14 bus system with multicontrol functional STATCOM model for have demonstrated by using MATLAB software. Furthermore, a comprehensive strategy for enforcement of the multi-violated STATCOM internal and external constraints has been proposed. numerical results show that the strategy proposed can enforce successfully the multiple violated voltage and constraints.

Referances

- [1]N. G. Hingorani, L. Gyugyi, "Understanding FACTS – Concepts and Technology of Flexible AC Transmission Systems," IEEE Press, New York, 2000.
- [2] K. R. Padiyar and A. M. Kulkarni, "Flexible AC transmission systems: A status review," Sat/hand, vol. no.22, Part 6, pp.781-796, December 1997.
- [3] Prabha kundur, "Power system stability and control," pp.17-18.
- [4]Annapurna Bhargava, Vinay Pant and Biswarup Das, "An Improved Power Flow Analysis Technique with STATCOM," International Conference on Power Electronic, Drives and Energy Systems, pp.1-5, December 2006.
- [5]Cesar Angeles-Camacho, Enrique Acha , " Three-phase STATCOM Models for Large-scale Newton-Raphson Power Flow Studies," IEEE Lausanne Power Tech, pp.1250-1255, July 2007.
- [6] Ramasami Natarajan, "Computer Aided Power System Analysis," Marcel Dekker, Inc.2002.
- [7] Y. Zhang, B. Wu and J. Zhou, "Power injection model of STATCOM with control and operating limits for power flow and voltage stability analysis," Electric Power System Research, vol. no.76, pp.1003-1010, August, 2006.
- [8] Enrique Acha, FACTS Modelling and Simulation in Power Network, John Wiley & Sons Ltd.
- [9] K. K. Sen, "STATCOM - Static Synchronous Compensator: Theory, Modeling and Applications," IEEE Power Engineering Society, vol. no.2, pp.1177-1183, January 1999.
- [10] Zhiping Yang, Chen Shen, Mariesa L. Crow, Lingli Zhang, "An Improved STATCOM Model For Power Flow Analysis," Power Engineering Society, vol. no.2, pp.1121-1126, July 2000.
- [11] Enrique Acha, and Behzad Kazemtabrizi, "A New STATCOM for Power Flows Using the Newton Raphson Method," IEEE Transaction on Power System, vol. no.28, pp.2455-2465, December 2013.
- [12] Shagufta Khan, Suman Bhowmick, "STATCOM Modeling For Power Flow Analysis," 6th IEEE Power India International Conference (PIICON), pp.1-6, December 2014.
- [13] Suman Bhowmick, Biswarup Das and Narendra kumar, "An Advanced Static Synchronous Compensator Model to Reuse Newton and Decoupled Power Flow Codes," Electric Power Component and System, pp.1647-1665, November 2011.

- [14] S. D. Sundarsingh Jebaseelan, Dr. R. Raja Prabu, "Performance of Thirty Bus System with and without STATCOM," International Conference on Trends in Electrical, Electronics and Power Engineering (ICTEEP'2012), pp.1-5, July 2012.
- [15] Suman Bhowmick, Biswarup Das, Narendra Kumar, "An Advanced IPFC Model to reuse Newton Power Flow Codes," IEEE Transaction Power system, vol. no. 24, pp.1-8, May 2009.
- [16] Laszlo Gyugyi, Kalyan K. Sen, Colin D. Schander "The Interline Power Flow Controller Concept: A New Approach to Power Flow Management in Transmission System," IEEE Transaction Power Delivery, vol. no.14, pp.1-9, July 1999.
- [17] Laszlo Gyugyi Colin, D. Schander, Kalyan K. Sen, "Static Synchronous Series Compensator: A Solid State Approach to the Series Compensation of Transmission Lines," IEEE Transaction Power System Vol. no.12, pp.406-417, January 1997.
- [18] S.K.Sethy and J.K.Moharana, "Design, Analysis and Simulation of Linear Controller of a STATCOM for Reactive Power Compensation on Variation of DC link Voltage," International Conference on Power, Energy and Control (ICPEC), pp.74-79, February 2013.
- [19] Shagufta Khan, Suman Bhowmick, "STATCOM modeling for power flow analysis," 6th IEEE Power India International Conference (PIICON), pp.1-6, December 2014.
- [20] F. Berrouk, B. Ali Rachedi, A. Lemzadmi, K. Bounaya, H. Zeghache, "Application of shunt FACTS controller for voltage stability improvement," International Conference on Electrical Sciences and Technologies in Maghreb (CISTEM), pp.1-6, November 2014.
- [21] Abayomi A. Adebisi and K.T. Akindeji, "Investigating the effect of static synchronous compensator (STATCOM) for voltage enhancement and transmission line losses mitigation," IEEE PES Power Africa, pp.462-467, June 2017.
- [22] Dung Vo Tien, Petr Hawliczek, Radomir Gono and Zbigniew Leonowicz, "Analysis and modeling of STATCOM for regulate the voltage in power systems," 18th International Scientific Conference on Electric Power Engineering (EPE), pp.1-4, May 2017.

