

ANALYSIS OF STRESSES INDUCED IN CONNECTING ROD OF TWO WHEELER ENGINE

Satish Wable¹, Dattatray S.Galhe²

¹M.E. Student, Department of Mechanical Engineering, Jaihind College of Engineering, Kuran, Pune, Maharashtra, India

²Asst. Professor, Department of Mechanical Engineering, Jaihind College of Engineering, Kuran, Pune, Maharashtra, India

ABSTRACT

An automobile engine connecting rod is a high volume production and critical component. Connecting rod is the connecting link between the piston and the crank. And transmit the push and pull from the piston pin to crank pin, therefore converting the reciprocating motion into the rotary motion of the crank. Basically connecting rods are manufactured using carbon steel and recently aluminum alloys are finding its application in connecting rod. In automobile engines, the connecting rod is subjected to cyclic loads. These are seen by high compressive loads due to combustion, and high tensile loads due to the connecting rod mass of inertia. The main objective of this project is the weight optimization of a connecting rod in an automobile engine. To get the idea about designing the connecting rod, various stress to be considered. While going across through design, the connecting rod may be tried by various materials and comparing the result of all materials. Finite Element Method (FEM) is useful for the modeling and analysis of connecting rod. The present work has been established to replace the existing connecting rod made of forged steel with the aluminum MMC connecting rod for weight optimization.

Keywords: connecting rod, stress analysis, ANSYS

1. INTRODUCTION

A Connecting rod is the link between the reciprocating piston and rotating crank shaft. Small diameter side of the connecting rod is connected to the piston by means of gudgeon pin. The big end diameter of the connecting rod is connected to the crankshaft by means of crankpin. The aim of the connecting rod is to convert the reciprocating motion of the piston into the rotary motion of the crankshaft. The connecting rods are usually forged out of the open hearth steel or sometimes even nickel steel or vanadium steel. For low to medium capacity high speed engines, these are often made of duraluminium or other aluminum alloys. However, with the progress of technology, the connecting rods these days are also cast from malleable or spheroid graphite cast iron. The different connecting rod steels are (40Cr8, 37Mn6, 35Mn6 Mo3, 35Mn6 Mo4, 40Cr4, 40Cr4 Mo3, 40NiCr4Mo2) etc. In general, forged connecting rods are compact and light weight which is an advantage from inertia view point, whereas cast connecting rods are comparatively cheaper, but on account of lesser strength their use limited to small and medium size petrol engines.

It has mainly three parts namely- a pin end, a shank region and a crank end. Pin end is connected to the piston assembly and crank end is connected to crankshaft. A combination of axial and bending stresses act on the rod in operation. The axial stresses are product due to cylinder gas pressure and the inertia force arising on account of reciprocating motion. Whereas bending stresses are caused due to the centrifugal effects. To provide the maximum rigidity with minimum weight, the cross section of the connecting rod is made as an I – section end of the rod is a solid eye or a split eye this end holding the piston pin. The big end works on the crank pin and is always split. In some connecting rods, a hole is drilled between two ends for carrying lubricating oil from the big end to the small end for lubrication of piston and the piston pin.

A major source of engine wear is the sideways force exerted on the piston through the connecting rod by the crankshaft, which typically wears the cylinder into an oval cross-section rather than circular, making it impossible for piston rings to correctly seal against the cylinder walls. Geometrically, it can be seen that longer connecting rods will reduce the amount of this sideways force, and therefore lead to longer engine life. However, for a given engine block, the sum of the length of the connecting rod plus the piston stroke is a fixed number, determined by the fixed distance between the crankshaft axis and the top of the cylinder block where the cylinder head fastens; thus, for a given cylinder block longer stroke, giving greater engine displacement and power, requires a shorter connecting rod (or a piston with smaller compression height), resulting in accelerated cylinder wear.

The connecting rod is under tremendous stress from the reciprocating load represented by the piston, actually stretching and being compressed with every rotation, and the load increases to the square of the engine speed increase. Failure of a connecting rod, usually called throwing a rod, is one of the most common causes of catastrophic engine failure in cars, frequently putting the broken rod through the side of the crankcase and thereby rendering the engine irreparable; it can result from fatigue near a physical defect in the rod, lubrication failure in a bearing due to faulty maintenance, or from failure of the rod bolts from a defect, improper tightening or over-revving of the engine. Re-use of rod bolts is a common practice as long as the bolts meet manufacturer specifications. Despite their frequent occurrence on televised competitive automobile events, such failures are quite rare on production cars during normal daily driving. This is because production auto parts have a much larger factor of safety, and often more systematic quality control.

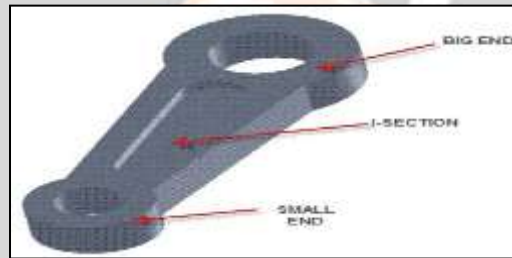

Fig.1 Schematic diagram of connecting rod

Finally, a weight optimization for connecting rod reduces the stresses over the entire rod. Due to its large volume production, it is only logical that optimization of the connecting rod for its weight or volume will result in large-scale savings. It can also achieve the objective of reducing the weight of the engine component, thus reducing inertia loads, reducing engine weight and improving engine performance and fuel economy.

1.1 Types of connecting rod.

1. Connecting rod with nut and bolt-The connecting rod with cap at the larger end is joined by means of bolt and nut as shown in fig.2. This type of connecting rod is most widely used in multi cylinder engines. For example trucks, tractor etc.



Fig.2 Connecting rod with nut and bolt

2. Connecting rod without nut and bolt – This type of connecting rod consists of single parts itself. And mostly used in single cylinder engine. For example bikes, scooter etc. This is shown in fig.3

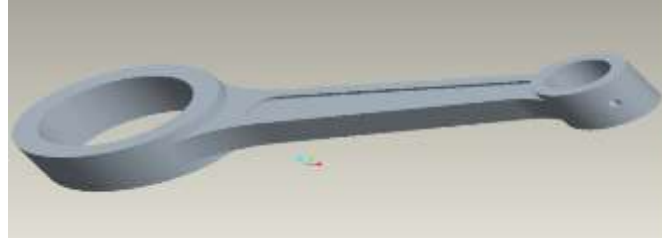

Fig.3 Connecting rod without nut- bolt.

1.2 Design considerations

A number of random designs would be generated by varying the values of the design variables within the specified limits before the Optimizer 'homed' in to the best design. As connecting rod is subjected to stresses caused by,

- combined effect of gas pressure on the piston and the inertia of the reciprocating parts,
- Friction of the piston rings and of the piston force and
- Inertia of the connecting rod.

This leads to stresses and deformation in connecting rod so a structural analysis of connecting rod has been carried out. The main objective of work is to suggest the optimum design parameter for the connecting rod. The optimization of connecting rod also achieve reducing the weight of the engine component, thus reducing inertia load, reducing engine weight and improving the engine performance and fuel economy. The main design parameter of the connecting rod is shown in the fig. 1.4

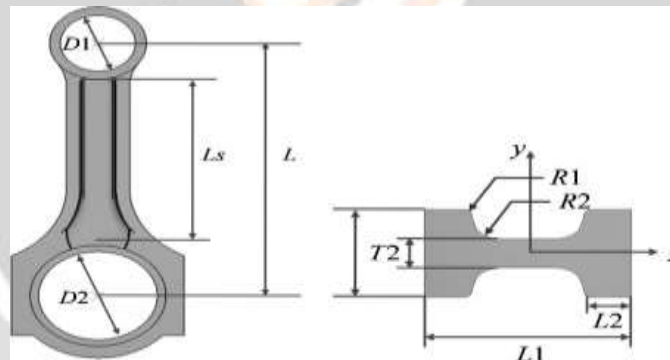

Fig.4 Design parameter of the connecting rod

D2 –Big end diameter connected to crankshaft

D1- Small end diameter connected to piston

Ls- I section length

L - Pitch length

L1- Total length

R2- Inner radius

T2- Thickness

R1-Outer radius

Table 1: Engine specifications for pulsar 180 cc bike

Parameters	Dimensions
No.of cylinders	1
Displacement	178.6cc
Max.Power	17.02@8500(Ps @RPM)
Max.Torque	14.22@6500(Nm@ RPM)
Bore	63 mm
Stroke	56 mm
Length of connecting rod	104.5 mm

Table2: Material properties of comparative materials

	Carbon Steel (16MnCr5)	Aluminum MMC
Young's modulus E [GPa]:	210	72.5
Poisson's ratio ν [-]:	0.3	0.33
Mass density ρ [kg/cm ³]:	7.8	2.8

2. LITERATURE REVIEW

There is a vast amount of literature related to Finite Element Analysis of weight optimization of connecting rod. Many research publications, journals, reference manuals, newspaper articles, handbooks; books are available of national and international editions dealing with basic concepts of FEA. The literature review presented here considers the major development in implementation of FEA.

Shahrulkh shamim et al studied finite element analysis of connecting rod used in single cylinder four stroke petrol engines. Static stress analysis is conducted on connecting rod made up of two different materials viz. E-glass/Epoxy and Aluminum composite reinforced with Carbon nano tubes. Modeling and comparative analysis of connecting rod is carried out in commercially used FEM software ANSYS 14.0. Static structural analysis was done by fixing the piston end and applying load at the crank end of the connecting rod. Output parameters in static stress analysis are von-Mises stress, Shear stress, total deformation and equivalent elastic strain for the given loading conditions. [1]

G. Naga Malleshwara Rao et al worked on Design Optimization and Analysis of a Connecting Rod. The main Objective of this work is to explore weight reduction opportunities in the connecting rod of an I.C. engine by examining various materials such as Genetic Steel, Aluminum, Titanium and Cast Iron. This was entailed by performing a detailed load analysis. Therefore, this study has dealt with two subjects, first, static load and stress analysis of the connecting rod and second, Design Optimization for suitable material to minimize the deflection. In the first of the study the loads acting on the connecting rod as a function of time are obtained. [2]

Pravardhan S. Shenoy et al performed optimization to reduce weight and manufacturing cost of a forged steel connecting rod. Since the weight of the connecting rod has little influence on its total production cost, the cost and the weight were dealt with separately. Reduction in machining operations, achieved by change in material, was a significant factor in manufacturing cost reduction. Weight reduction was achieved by using an iterative procedure. Literature survey suggests cyclic loads comprised of static tensile and compressive loads are often used for design and optimization of connecting rods. However, in this study weight optimization is performed under a cyclic load comprising dynamic tensile load and static compressive load as the two extreme loads. Constraints of fatigue

strength, static strength, buckling resistance and manufacturability were also imposed. The fatigue strength was the most significant factor in the optimization of the connecting rod. [3]

Tony George Thomas et al studied Heavy duty application's connecting rod. The analytically calculated loads acting on the small end of connecting rod were used to carry out the static analysis using ANSYS. A stress concentration was observed near the transition between small end and shank. A piston-crank-connecting rod assembly was simulated for one complete cycle (0.02 seconds) using ADAMS to obtain the loads acting on small end of connecting rod. This force vs. time graph was converted into an equivalent stress vs. time graph. [4]

Deepak G. Gotiwale et al studied redesigning of connecting rod for its weight reduction using c70s6 material. During its operation connecting rod undergoes various types of loads. Fatigue as well as static stresses are mainly responsible for failure of a connecting rod. Initially fatigue testing was carried out for studying failures during its life cycles. But after recognizing these failures during fatigue testing, Fatigue life further enhanced by incorporating few changes and then analyzed with the help of FEA for highlighting critical points on connecting rod. The new connecting rod geometry is lighter than original connecting rod. [5]

Hitesh Kumar et al. did analysis of connecting rod and get idea of stress producing compressive loading. And then give idea about weight reduction opportunities in connecting rod of an I.C. engine by examining two materials, AISI 1040 carbon steel and AISI 4340 alloy steel. This has entailed performing a detailed load analysis. Therefore, this study has deal with two subjects, first, static load and stress analysis of the connecting rod and second optimization for weight reduction and shape. Structural system of connecting rod has been analyzed using FEA. With the use of FEA von-misses stress, strain, shear stress, deformation, and weight reduction etc, were calculated for a particular loading conditions using FEA Software ANSYS WORKBENCH 14.0. The same work was done on the same design for other different materials. Compared to the former material the new material found to have less weight, stress reduction and better stiffness. [6]

3. EXPERIMENTAL PROCEDURE

Analysis done with pressure load applied at the piston end and restrained at the crank end or other load applied at the crank end and restrained at the piston end. The finite element analysis is carried out on carbon steel (16MnCr5) connecting rod as well as on aluminium MMC.

The CAD model of connecting rod of Carbon steel (existing product) and Aluminium MMC is developed in CATIA V5R19 is shown in fig.2.1. These meshed models of connecting rod of Carbon steel (existing product) and Aluminium MMC is shown in fig. 2.2. Analysis is carried out on these meshed models of connecting rod in ANSYS 14. From the analysis the equivalent stress (Von-mises stress), displacements were determined and are shown in figure 5-8. Table 1 shows the comparative results for different materials.

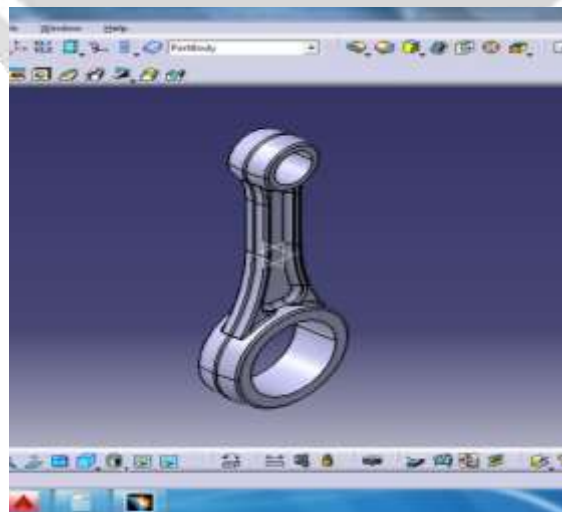

Fig.5 3D model of existing connecting rod

3.1 3D model of connecting rod

A connecting rod of two wheeler engine of pulsar 180cc is designed for two different materials. Existing material of connecting rod is 16MnCr5 (Carbon steel). Alternate material selected for connecting rod is MMC. 3D model of both the connecting rods are as shown below.

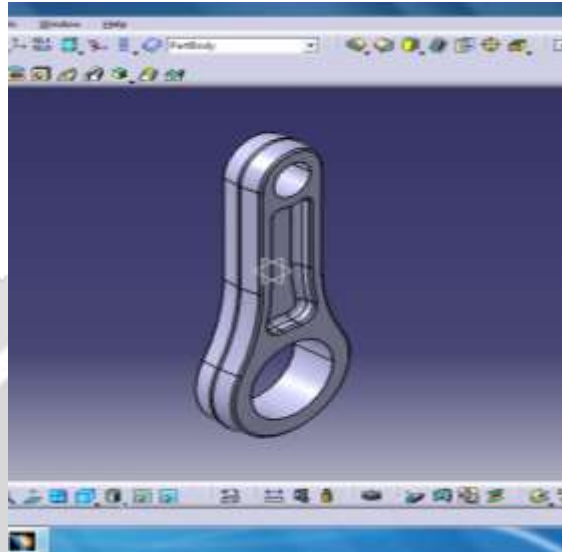

Fig.6 3D model of Aluminum MMC material.

3.2 Meshed model of connecting rod

After preparing 3D model of connecting rod of two different materials, these models are imported in ANSYS 14 software for stress analysis. After importing the models are meshed in finite elements. Meshed model of connecting rods are as shown below.

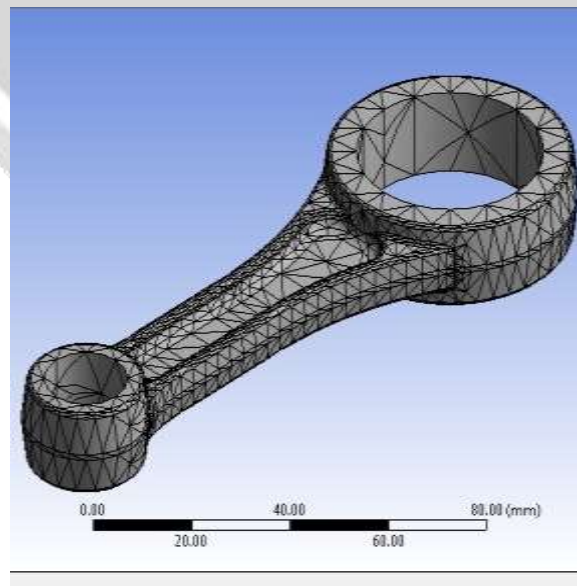

Fig.7 Meshed model of existing connecting rod

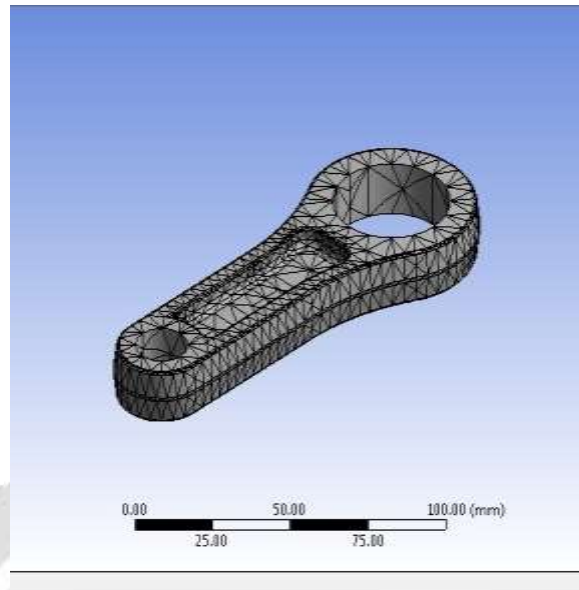

Fig.8 Meshed model of Aluminum MMC connecting rod.

3.3 Stresses induced in connecting rod

Stresses induced in connecting rod due to compression loading are determined from finite element method. Induced stresses are shown in below figures. Stressed induced in existing connecting rod is 421 MPa and in Aluminium MMC is 176 MPa.

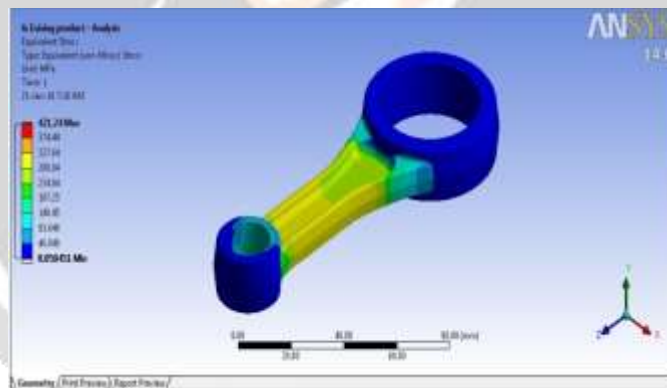

Fig.9 Stresses induced in existing connecting rod

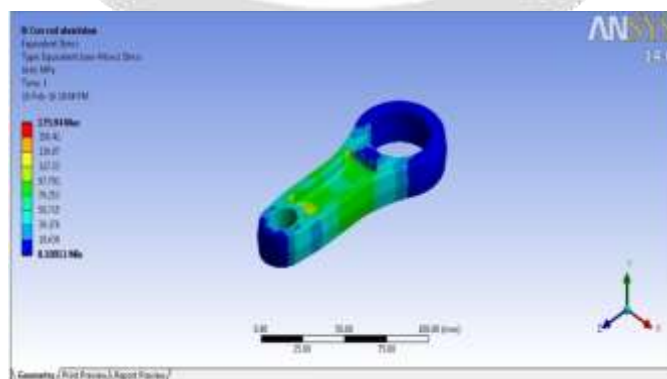

Fig.10 Stresses induced in Aluminum MMC

3.4 Deformation of connecting rod

Deformation of connecting rod due to compression loading is determined from finite element method. Deformation of connecting rod is shown in below figures. Deformation of existing connecting rod is 0.1 mm and in Aluminium MMC is 0.1mm

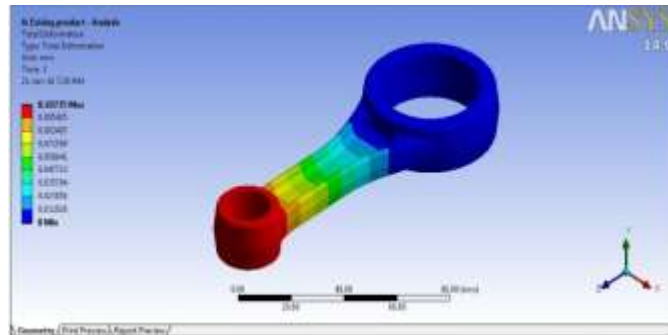

Fig.11 Deformation of existing connecting rod

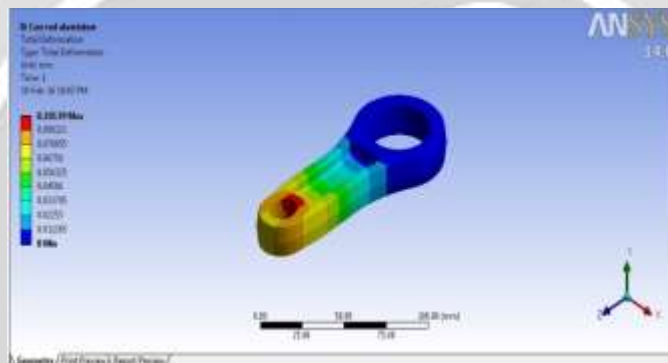

Fig.12 Deformation of Aluminum MMC connecting rod.

3.5 Comparison of FEA results for stresses & deformation

Table 3: Comparison of FEA results

Material	Carbon Steel 16MnCr5	Aluminum MMC
Total deformation	0.1 mm	0.1 mm
Equivalent stress	421 MPa	176 MPa

3.6 Weight comparison of two materials

Table 4: Weight comparison

Material	Carbon Steel 16MnCr5	Aluminum MMC
Total weight	230 gm	155 gm
Weight after drilling and notches	199 gm	150 gm

4. CONCLUSION

The present work was aimed at evaluating alternate material for connecting rod with lesser stresses and lighter weight. This work found alternate material for minimizing stresses in connecting rod. FEA analysis performed using ANSYS 14 software for determining stresses & deformation. The following conclusions can be drawn from this study.

The Aluminum MMC connecting rod shows less amount of stresses (ie.41%) than existing carbon steel (16MnCr5) connecting rod.

The deflection of Aluminum MMC connecting rod is same (ie. 0.1 mm) compared to deflection of existing carbon steel (16MnCr5) connecting rod.

It is also found that the Aluminum MMC connecting rod is light in weight (ie.23%) than existing carbon steel (16MnCr5) connecting rod approximately.

5. FUTURE SCOPE

The connecting rod can be further modified with suitable alternate material for weight optimization.

6. ACKNOWLEDGEMENT

It is a pleasure for me to present this paper where guidance plays an invaluable key and provides concrete platform for completion of the paper. I would also like to express my sincere thanks to my internal guide Asst.Prof. D.S.Galhe, Department of Mechanical Engineering, for his unfaltering encouragement and constant scrutiny without which I wouldn't have looked deeper into my work and realized both our shortcomings and our feats. I am also grateful to other researchers and authors whose work provided a platform for this paper.

7. REFERENCES

- [1]Shahrukh Shamim,Design and Comparative Analysis of Connecting Rod using Finite Element Method,IJERT, Vol. 3 Issue 9, September- 2014
- [2]G. Naga Mallechwara Rao ,Design Optimisation and Analysis of a Connecting Rod using ANSYS, IJSR,Vol.2,Issue 7,July 2013
- [3] Pravardhan S. Shenoy and Ali Fatemi, Connecting Rod Optimization for Weight and Cost Reduction, SAE International,2005
- [4] Tony George Thomas, S.Srikari, M.L.J.Suman, Design Of Connecting Rod For Heavy Duty Applications Produced By Different Processes For Enhanced Fatigue Life , SAS TECH Journal, Vol. 10,Issue 1,May 2011
- [5] Deepak G. Gotiwale, Shailesh D.Ambekar, Design Of Connecting Rod For Weight Reduction Using C70S6 Material. IJSER, Vol.5, Issue5, 2014
- [6]Hitesh Kumar, 2, Vijay Kumar Sharma, Department of Mechanical Engineering Stress Analysis and Optimization of I. C. Engine Connecting Rod by Finite Element Analysis ,IJERT Vol. 4 Issue 04, April-2015
- [7] M Sayeed Ahmed, Sirajuddin Elyas Khany, Syed Hamza Shareef, Design Fabrication and Analysis of a Connecting Rod with Aluminum Alloys and Carbon Fibre,IJRSET,Vol.3,Issue10,2014
- [8] DR. B.K.Roy, Design Analysis and Optimization of Various Parameters of Connecting Rod using CAE Software, IJNIET, Vol. 1 Issue 1 October 2012
- [9] Jones R. M., "Mechanics of composite materials", 2e, McGraw-Hill Book Company, New York. 1990