

# A Wireless Sensor Monitoring Node Based on Automatic Tracking Solar-Powered Panel for Paddy Field Environment

S.Y.Bhangale<sup>1</sup>, A.S.Bhide<sup>2</sup>

*PG Student [CE], Dept. of ECE SSGB College of Engineering & Technology, Bhusawal, Maharashtra, India<sup>1</sup>*

*Assistant professor, Dept. of ECE SSGB College of Engineering & Technology, Bhusawal, Maharashtra, India<sup>2</sup>*

## ABSTRACT

*In order to realize the collection, management, visualization and uploading of real-time information in the paddy field, an information monitoring node based on automatic tracking solar-powered panel is presented in this paper. Initially, the node consists of information collecting sensors, Arduino, LCD, GSM module, automatic tracking solar-powered module and monitoring interface. Secondly, data gathered from sensors can be displayed on the LCD and sent to the mobile phones. The mobile phones are used for examination and analysis. Finally, in test time data's are gathered every ten minutes. At non-test time, the system works in low-power mode to achieve rational use of electric energy. All the gathered parameter values are displayed in the LCD. When the values exceed the normal rates, an alert message will be sent to the farmer's mobile through a GSM module. The results of this project can achieve an accurate transmission and display of data. A microcontroller based design methodology of an automatic solar tracker is presented in this paper. Light dependent resistors are used as the sensors of the solar tracker. The designed tracker has precise control mechanism which will provide three ways of controlling system. A small prototype of solar tracking system is also constructed to implement the design methodology presented here. Solar energy is fast becoming a very important means of renewable energy resource.*

**KEYWORDS:** *Wireless sensor, GPRS, Arduino, LCD, Solar power Panel, STM32, Environment monitoring.*

## I.INTRODUCTION

Rice is one of the most important food crops around the world [1-3], although its planting area is less than 30% of the total area of grain crops, and the yield is close to 40% of the total grain output [4]. Rice is the grain crop that needs more water [5]. It is pivotal to control the water level accurately according to the water requirements rule of rice in different stages, and it can also greatly reduce the waste of water resource, irrigation costs, and make the cultivation in paddy field more scientific. Energy is the prime factor for the development of a nation. An enormous amount of energy is extracted, distributed, converted and consumed in the global society daily. 85% of energy production is dependent on fossil fuels [1]. The resources of the fossil fuels are limited and their use results in global warming due to emission of greenhouse gases. To provide a sustainable power production and safe world to the future generation, there is a growing demand for energy from renewable sources like solar, wind, geothermal and ocean tidal wave. The sun is the prime source of energy, directly or indirectly, which is also the fuel for most renewable systems. Among all renewable systems, photovoltaic system is the one which has a great chance to replace the conventional energy resources. Solar panel directly converts solar radiation into electrical energy. Solar panel is mainly made from semiconductor materials. Si used as the major component of solar panels, which is maximum 24.5% efficient [2]. Unless high efficient solar panels are invented, the only way to enhance the performance of a solar panel is to increase the intensity of light falling on it. A solar tracker is a device used for orienting a photovoltaic array solar panel or for concentrating solar reflector or lens toward the sun. The position of the sun in the sky is varied both with seasons and time of day as the sun moves across the sky. Solar powered equipment work best when they are pointed at the sun. Therefore, a solar tracker increases how efficient such equipment are over any fixed position at the cost of additional complexity to the system. Solar energy is clean and available in abundance. Solar technologies use the sun for provision of heat, light and electricity.

These are for industrial and domestic applications. With the alarming rate of depletion of depletion of major conventional energy sources like petroleum, coal and natural gas, coupled with environmental caused by the process of harnessing these energy sources, it has become an urgent necessity to invest in renewable energy sources that can power the future sufficiently. The energy potential of the sun is immense. Despite the unlimited resource however, harvesting it presents a challenge because of the limited efficiency of the arraycells. The best efficiency of the majority

of commercially available solar cells ranges between 10 and 20 percent. This shows that there is still room for improvement. This project seeks to identify a way of improving efficiency of solar panels. Solar tracking is used. The tracking mechanism moves and positions the solar array such that it is positioned for maximum power output. Other ways include identifying sources of losses and finding ways to mitigate them.

## II. LITERATURE REVIEW

This literature review reveals the detailed work that has been carried out till date on the topic of Solar Tracking H. Luo, G. Li and W. Peng, “Real-time remote monitoring system for aquaculture water quality and two-axis sun tracking system with the use of five LDRs and an Arduino UNO controller [4]. The objective of this research is to design and construct the automatic dual axis solar tracker for maximum sun energy utilization. The only point of worry is that this system should consume energy as minimum as possible so that the difference between power conversion and power consumption would increase and hence the net profit of the system. Arduino UNO controller has been used and it is programmed in C language. LDRs are used to detect the maximum sunlight position in the sky and the program written performs calculations and drives the servo motors to make PV panels perpendicular to the sun [1].

The sun not only travels from east to west but there is a change of angle in north to south direction also. So the north and south directions should also be taken care of. Dual axis trackers do that. These trackers track the sun on a horizontal as well as vertical axis. Because of this operating ability the dual axis trackers have more output power than the single axis trackers. Light Dependent Resistors are used to find the brightest spot of the sun in the sky. LDRs are connected to Arduino UNO controller which gets to know the position of the sun in the sky and hence rotates the motors towards the sun. Two Servo motors are used for panel rotation which also fulfills the low cost and lightweight criteria [1].

EA Chiaradia, A. Facchi, D. Masseroni and D. Ferrari, “An integrated, multisensor system for the continuous monitoring of water dynamics in rice fields under different irrigation regimes and also designed and constructed a microcontroller based solar tracking system using LDRs to sense the intensity of sunlight and stepper motors to move the Photo-Voltaic (PV) panels in accordance with the sun [3].

H. Navarro-Hellín, R. Torres-Sánchez and F. Soto-Valles, have designed and implemented A wireless sensors architecture for efficient irrigation water management .

N. T. Son, C. F. Chen and L. Y. Chang, “A logistic-based method for rice monitoring from multitemporal MODIS-Landsat fusion data The hardware is selected such as it will maximize the power collected and minimize the power consumed as the efficiency parameter lies in between these two power parameters [2].

## III. SYSTEM MODEL AND ASSUMPTIONS

The objective of the project was to design a system that tracks the sun for a solar panel. This was achieved through using light sensors that are able to detect the amount of sunlight that reaches the solar panel. the system is developed under monitoring node such as solar powered panel , lcd, sensors, battery , controller etc,

### Working of System

The two Transceivers are designed here System works in two parts

- 1) Transmitter
- 2) Receiver

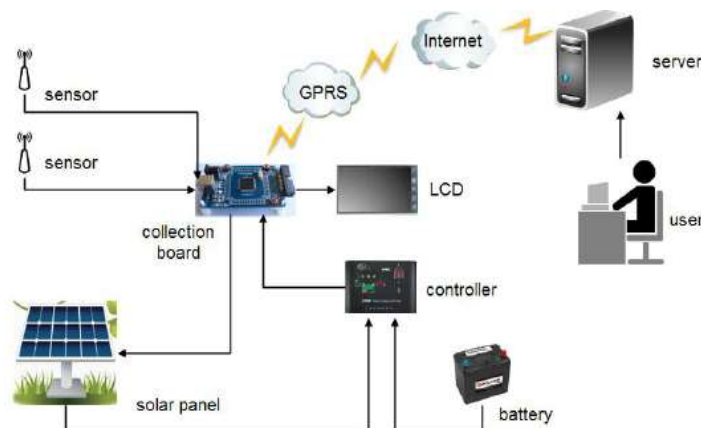



Fig.1 The overall framework of monitoring node

1) Transmitter Section

2) Receiver Section

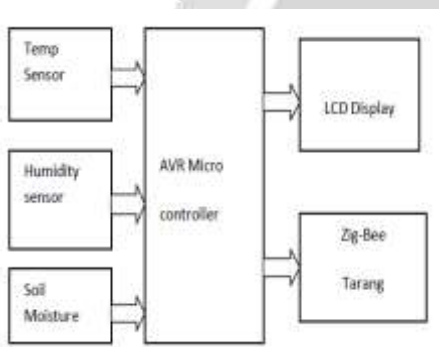

Fig.2 Block Diagram of Transmitter

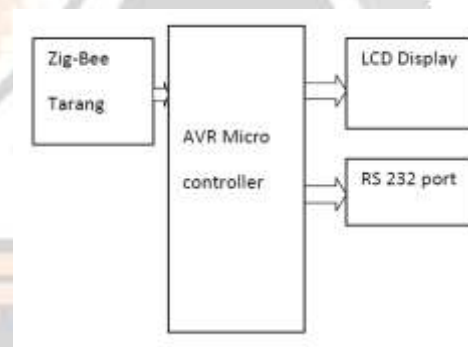

Fig.3 Block Diagram of Receiver

A. Transmitter

Initially power is on. After this system is reset. Signals are read by different sensors and its output is given to microcontroller. Output to microcontroller from sensor is taken through 8 channel ADC pins. The output from microcontroller is given to Zigbee through Rx and Tx pins

B. Receiver

At receiver side ZigBee come into picture. There is only one Tx and Rx pins Signal is send to microcontroller and parameters like temperature, soil moisture and humidity are monitored. These parameters are monitored on computer using RS-232 port. This data can be used for precision farming The actuators can be controlled using microcontroller data. This is how total working takes place of automation irrigation system. Different sensors like moisture and temperature sensor senses the moisture content and temperature required. Thus it helps to provide a proper environment to grow crops easily. A different technique of irrigation has been used to irrigate the field. First water is stored in tanks trough pipes then different sources like sprinklers and drip irrigation can be used as both are suitable to irrigate crops.

In crop field we have to irrigate the land fully. We have to irrigate depending upon the soil, ups and downs of the land and where it needs.

i) We have designed ZigBee wireless sensor network for monitoring the crop field area by deploying moisture sensors in the land to detect the places where the water level is low. From those results we can irrigate to that particular place only. So we can conserve water and minimize the problem of water logging in the land.

ii) We used humidity sensor to sense the weather. By this the farmer can get idea about the climate. If there is any chance for rainfall, the farmer need not irrigate the crop field. Due to this we can conserve water and also power since we dint turn on motors.

iii) Nowadays in the crops the fertilizer level is increasing, which affects people. By using pH sensors we get the information about the soil and analyze the acid level of the soil. By which we can apply fertilizer to the place where it needs, also we can avoid over fertilization of the crops. Temperature is a randomly varying quantity in the environment of paddy field. Temperature reading gives information to the farmer. By using temperature sensors we can detect the temperature.

#### A) ARDUINO

Arduino is an open-source electronics prototyping platform based on flexible, easy-to use hardware and software. It's intended for artists, designers, hobbyists, and anyone interested in creating interactive objects or environments.

Arduino can sense the environment by receiving input from a variety of sensors and can affect its surroundings by controlling lights, motors, and other actuators. The microcontroller on the board is programmed using the Arduino programming language and the Arduino Development Environment. Arduino projects can be stand-alone, or they can communicate with software running on a computer.

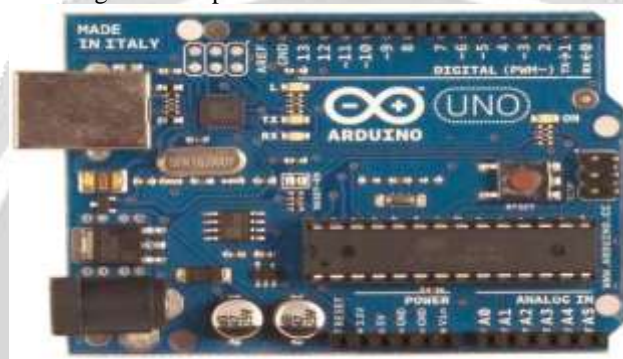

Fig .4 Arduino

Arduino The Arduino Uno is a microcontroller board based on the ATmega328. It has 14 digital Input/output pins (of which 6 can be used as PWM outputs) 6 analog inputs, a 16 MHz crystal oscillator, a USB connection, a power jack, an ICSP header, and a reset button. It contains everything needed to support the microcontroller connect it to a computer with a USB cable or power it with a AC-to-DC adapter or battery to get started.

The Arduino Uno is a microcontroller board based on the ATmega328. It has 14 digital Input/output pins (of which 6 can be used as PWM outputs) 6 analog inputs, a 16 MHz crystal oscillator, a USB connection, a power jack, an ICSP header, and a reset button. It contains everything needed to support the microcontroller connect it to a computer with a USB cable or power it with a AC-to-DC adapter or battery to get started.

#### B)Sensors

There are five types of sensors in this node: temperature, soil moisture content, illumination intensity and water level. temperature sensor When the voltage increases then the temperature also rises. Contact sensors include thermocouples and thermistors that touch the object they are to measure , and non contact Sensors measure the thermal radiation a heat source releases to determine its temperature.

##### A) Temperature sensor

The LM35 series are precision integrated-circuit temperature sensors, whose output voltage is linearly proportional to the Celsius (Centigrade) temperature It is low cost and small size sensor. Its temperature range is  $-55^{\circ}$  to  $+150^{\circ}\text{C}$ .

When the voltage increases then the temperature also rises. Contact sensors include thermocouples and thermistors that touch the object they are to measure , and non contact Sensors measure the thermal radiation a heat source releases to determine its temperature.

DS18B20 temperature sensor adopts the unique single-wire interface mode, when it is connected to microcontroller, there is only one single-wire architrave to realize both-way communication between microcontroller and DS18B20



means that further increasing the light intensity to the CdS cells will not decrease its resistance any further. Light intensity is measured in Lux, the illumination of sunlight is approximately 30,000 lux

Normally the resistance of an LDR is very high, sometimes as high as 1000 000 ohms, but when they are illuminated with light resistance drops dramatically. When the light level is low the resistance of the LDR is high. This prevents current from flowing to the base of the transistors. Consequently the LED does not light. However, when light shines onto the LDR its resistance falls



Fig.7 Light dependent resistor (LDR) with result

The stable position is when the two LDRs having the same light intensity. When the light source moves, i.e. the sun moves from west to east, the level of intensity falling on both the LDRs changes and this change is calibrated into voltage using voltage dividers. The changes in voltage are compared using built-in comparator of microcontroller and motor is used to rotate the solar panel in a way so as to track the light source. A Light Sensor generates an output signal indicating the intensity of light by measuring the radiant energy that exists in a very narrow range of frequencies basically called “light”, and which ranges in frequency from “Infra-red” to “Visible” up to “Ultraviolet” light spectrum



### C) Soil Moisture Sensor

The soil moisture sensor used is capacitive type. The sensor gives analog output of zero volt when there is 100% moisture and 5V for 0% moisture. Soil moisture sensors measure the volumetric water content in soil.[1] Since the direct gravimetric measurement of free soil moisture requires removing, drying, and weighting of a sample, soil moisture sensors measure the volumetric water content indirectly by using some other property of the soil, such as electrical resistance, dielectric constant, or interaction with neutrons, as a proxy for the moisture content.

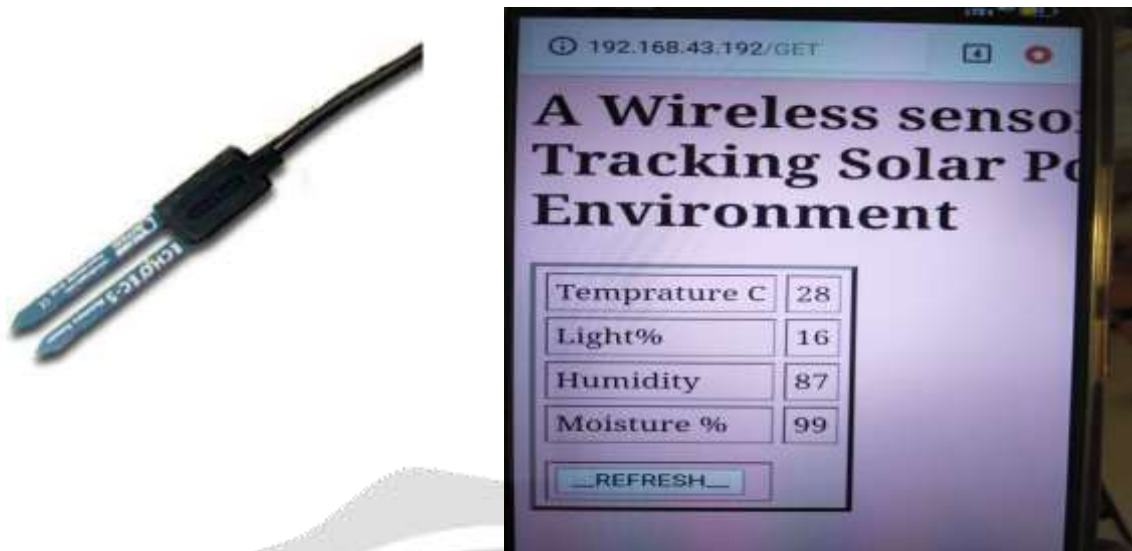

Fig 7 Soil Moisture Sensor with result image

### Photovoltaic Technology

The most abundant and convenient source of renewable energy is solar energy, which can be harnessed by photovoltaic cells. Photovoltaic cells are the basic of the solar system. The word photovoltaic comes from “photo” means light and “voltaic” means producing electricity. Therefore, the photovoltaic process is “producing electricity directly from sunlight”. The output power of a photovoltaic cell depends on the amount of light projected on the cell. Time of the day, season, panel position and orientation are also the factors behind the output power. Photovoltaic cells are the smallest part of a solar panel. Solar panel gives maximum power output at the time when sun is directly aligned with the panel.

Technology To Enhance Power Output From Solar Panel Increasing the cell efficiency, maximizing the power output and employing a tracking system with solar panel are three ways to increase the overall efficiency of the solar panel[4]. Improvement of solar cell efficiency is an ongoing research work and people throughout the world are actively doing research on this. Maximizing the output power from solar panel and integrating solar tracking system are the two ways where electronic design methodology can bring success. Maximum power point tracking (MPPT) is the process to maximize the output power from solar panel by keeping the solar panel's operation on the knee point of P-V characteristics. A number of MPPT algorithms have been developed and employed around the world [5]

#### 1) The Master Control Chip

The master control chip presented in the node is STM32F103VE based on Cortex-M3 ARM kernel, it is widely used in the application of embedded system because of its high-performance, low cost and low power consumption. The working frequency is 72MHz, and there are built-in high speed memory, 512K bytes of flash memory and 64 bytes of SRAM, abundant enhanced I/O ports and peripherals connected to two APB buses, three 12-bit ADC modules, and four general-purpose 16-bit timers. In addition, there are also standard and advanced communication interfaces, two I2C buses, three SPIs, two I2Ss, one SDIO, five USARTs, one USB and one CAN.

#### 2) Sensors

Wireless sensor network refers to a group of spatially dispersed and dedicated sensors for monitoring and recording the physical conditions of the environment and organizing the collected data at a central location. WSNs measure environmental conditions like temperature, sound, pollution levels, humidity, wind, and so on. These are similar to wireless ad hoc networks in the sense that they rely on wireless connectivity and spontaneous formation of networks so that sensor data can be transported wirelessly. WSNs are spatially distributed autonomous sensors to monitor physical or environmental conditions, such as temperature, sound, pressure, etc

There are five types of sensors in this node: temperature, soil moisture content, pH value, illumination intensity and water level. Their models and technical parameters are listed in Table I.

TABLE I  
PERFORMANCE INDEX OF SENSORS

Sensors	Voltage Range (V)	Measurement Range	Collection Means
DS18B20	3.0-5.5	-55-+125(°C)	Single Bus
pH	3.5-5	0-14	ADC1
TSL2561	4.8-5.2	0-40000(Lux)	I2C Bus
FC-28	3.3-5	0-100%(RH)	ADC1
AT35-3	3.3-5	0-30(cm)	ADC1

Table 1 Performance index of Sensor

3) GPRS Module

We use wireless communication mode of GPRS network to realize the data transmission in this node. GPRS service provides point-to-point PPP link, which adopts the wireless IP technology based on packet transfer mode and supports TCP/IP protocol and X.25 protocol, and it is accessed to Internet through GSM network. The initialization of status and frequency of wireless module is required before the dial-up.

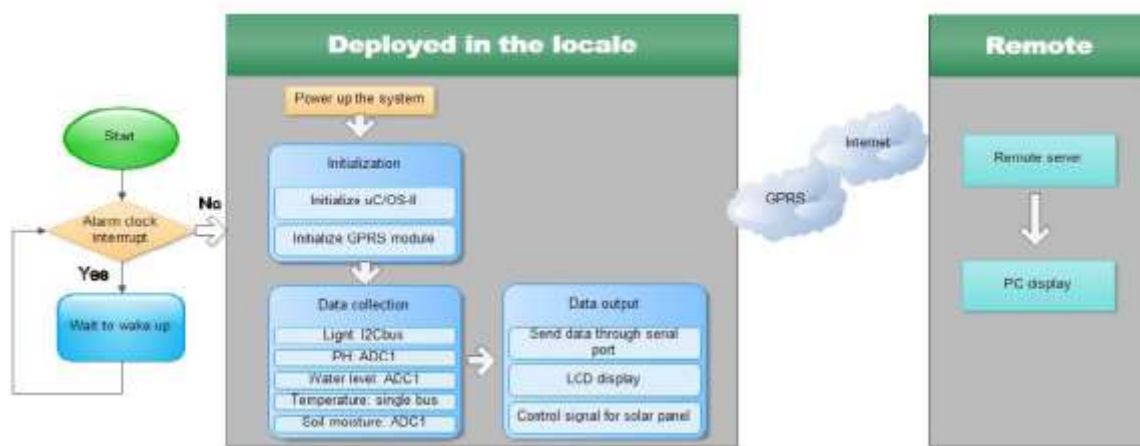

Fig. 13. The flow chart of the software design in the node

GPRS covers a wide range of area and billing according to the flow, and there are just a few seconds spent to build a new wireless connection, and the network connection can be carried out at any time.

VI. CONCLUSION

Zigbee-based agriculture monitoring system serves as a reliable and efficient system for monitoring agricultural parameters. The corrective action can be taken. Wireless monitoring of field not only allows user to reduce the human power, but it also allows user to see accurate changes in it. It is cheaper in cost and consumes less power. The GDP per capita in agro sector can be increased. This project can be extended for cattle monitoring. The paper has presented a means of tracking the sun’s position with the help of microcontroller. Specially, it demonstrates a working software solution for maximizing solar cell output by positioning a solar panel at the point of maximum light intensity. The prototype represents a method for tracking the sun both in normal and bad weather condition. Moreover, the tracker can initialize the starting position itself which reduce the need of any more photo resistors. The attractive feature of the designed solar tracker is simple mechanism to control the system.

ACKNOWLEDGEMENT

I would like to express the deepest appreciation to my guide Prof. A.S. Bhide for their help to complete this paper. I would also like to thank my HOD Dr. G.A. Kulkarni for their great support , also thanks to SSGB College of Engineering to provide lab and instrument to me for my work . At last but not least , I am thankful my parents who support and encourage me for this works



**REFERENCES**

- [1] L. Ranghetti, L. Busetto, A Crema, "Testing estimation of water surface in Italian rice district from MODIS satellite data". *International Journal of Applied Earth Observation & Geoinformation*, vol. 52, no.7, pp. 284-295, Oct. 2016.
- [2] M. Campos-Taberner, F. J. García-Haro and R. Confalonieri, "Multitemporal Monitoring of Plant Area Index in the Valencia Rice District with PocketLAI". *Remote Sensing*, vol. 8, no. 3, pp. 192-209, Mar. 2016.
- [3] EA Chiaradia, A. Facchi, D. Masseroni and D. Ferrari, "An integrated, multisensor system for the continuous monitoring of water dynamics in rice fields under different irrigation regimes". *Environmental*
- [4] H. Luo, G. Li and W. Peng, "Real-time remote monitoring system for aquaculture water quality". *International Journal of Agricultural & Biological Engineering*, vol. 8, no. 16, pp. 136-143, Dec. 2015.
- [5] I. Heimann, V. B. Bright and M. W. McLeod, "Source attribution of air pollution by spatial scale separation using high spatial density networks of low cost air quality sensors". *Atmospheric Environment*, vol. 113, no. 11, pp. 10-19, Jul. 2015.
- [6] Haefke, M., Mukhopadhyay S.C and Ewald, H. "A Zigbee Based Smart Sensing Platform for Monitoring Environmental Parameters". *Proceedings of IEEE International Conference on Instrumentation and Measurement Technology* pp1-8 May 2011.
- [7] HoSeong Cho, DaeHeon Park, Chul-Young Park, Hong-Geun Kim, Chang-Sun Shin, Yong-Yun Cho, and Jang-Woo Park "A study on localization based Zigbee and Monitoring system in Greenhouse environment". *Proceedings of IEEE 3rd International Conference on Data Mining and Intelligent Information Technology Applications* PP190-195 oct 2011..
- [8] Jeong-hwan Hwang and Hyun Yoe "Paprika Greenhouse Management System for Ubiquitous Agriculture"; *Proceedings of IEEE International Conference on Information and Communication Technology Convergence* pp555-556 Nov 2010
- [9] Na Pang "Zigbee Mesh Network for Greenhouse Monitoring"; *Proceedings of IEEE International Conference on Mechatronic Science, Electric Engineering and Computer* PP266-269 Aug 2011.
- [10] *International Journal of Engineering and Innovative Technology (IJEIT)* Volume 2, Issue 8, February 2013 72 A Wireless Remote Monitoring Of Agriculture Using Zigbee Gopala Krishna Moorthy .K, Dr .C.Yaashuwanth , Venkatesh. K.

