

# A study on Zn/C based Pathor Kuchi Leaf (PKL) electrochemical cell

<sup>1</sup>K.A. Khan, <sup>2</sup>Md. Anowar Hossain, <sup>3</sup>Md. Robiul Islam & <sup>4</sup>Md. Abdul Mannan

<sup>1</sup>Department of Physics, Jagannath University, Dhaka-1100, Bangladesh

<sup>2</sup>Center for Research Reactor, Bangladesh Atomic Energy Commission, Bangladesh

<sup>3</sup>Center for Research Reactor, Bangladesh Atomic Energy Commission, Bangladesh

<sup>4</sup>Central Engineering Facilities, Bangladesh Atomic Energy Commission

## Abstract

*It has been studied the performances of Zn/Cu based electrochemical cell previously. This paper shows the performances of Zn/C based PKL electrochemical cell. Carbon (C) electrode has been used instead of Copper (Cu) electrode. Different electric parameters like open circuit voltage, Short circuit current, maximum power, Load power, Load voltage, Load Current, Internal resistance have been studied. It is shown that the internal resistance lies between 3 ohm and 4.2 ohm, which is relatively high to the real values. Carbon (C) electrode use is the novelty of this research article.*

## I. Introduction

Carbon(C) is relatively low price with respect to the Cu electrodes. In this case no secondary salt has been used. PKL is available for everywhere. Because it grows everywhere. It has a great medicinal value. That is why it called miracle leaf. The zinc material is called anode material. It is also called sacrificial electrode. The both carbon and zinc materials are available in the local market and comparatively low price. This work may be the new guide line for near future. Oil, gas and coal are the mineral sources. It will be finished within short time all over the world. Then the renewable energy sources have to used. The renewable energy sources are solar energy, wind energy, geothermal energy, biogas energy, biomass energy, water energy, tidal energy, wave energy and OTEC etc. Our research work is the example of biomass energy.

**Key words:** Zn/C electrodes, PKL extract, PKL electrochemical cell, PKL electricity, Internal resistance

## II. Methodology:

The total observation was for 90 hrs. After certain period the reading was collected by a calibrated multimeter.

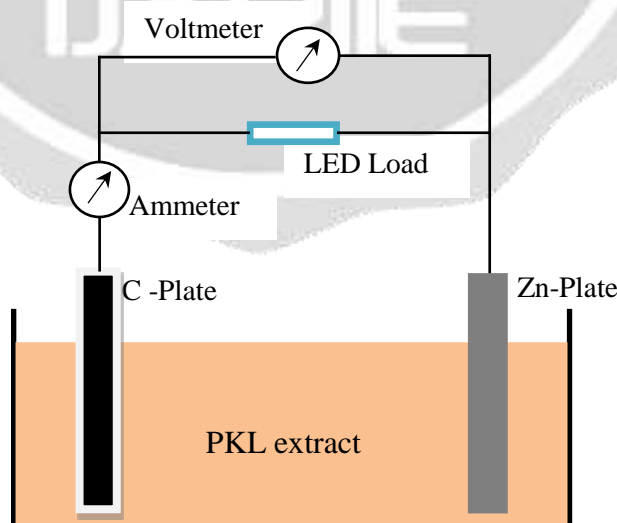

Fig.1 Basic principle of Zn/C based PKL electrochemical cell

Fig.1 shows the experimental set-up of the basic principle of Zn/C based PKL electrochemical cell. Here C-plate acts as a cathode and Zn-plate acts as an anode. PKL (Pathor Kuchi Leaf) acts as an electrolyte.



Fig.2 A PKL tree for leaf collection

Fig.2 shows the PKL tree. Leaves have been collected from this tree. After collection it has been blended by a blender machine. The produced extract has been filtered by the what man paper 41 and 42. The longevity of the PKL extract is around 12 years.



Fig.3 An experimental set up of Zn/C based electrochemical cell

Fig.3 shows an experimental set-up of a PKL electrochemical cell. There are 4- pairs of Zinc electrodes and 4 – pairs of Carbon electrodes. They are in series connection with the connecting wire. A calibrated multimeter has been used to measure the current, voltage and resistance.

### III. Results and discussion

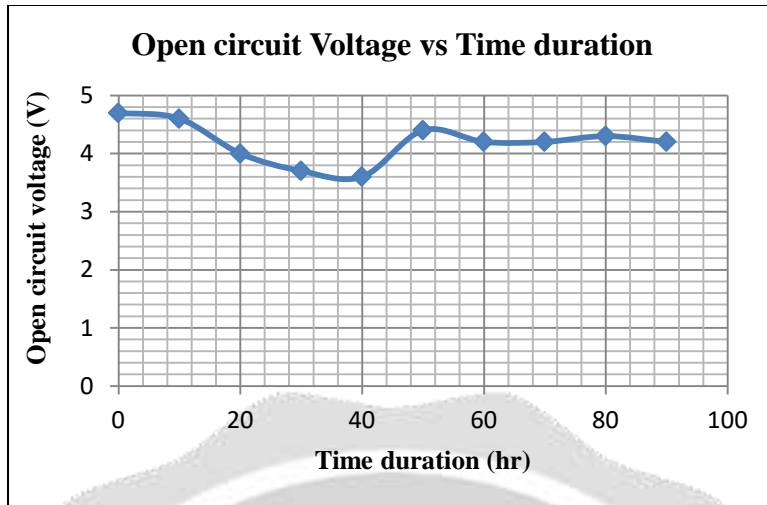

Fig.4 Open circuit Voltage vs Time duration

Fig.4 shows the Open circuit Voltage vs time duration curve. It is shown that the open circuit Voltage decreases slowly up to 40 hrs and then it increases exponentially up to 60 hrs and then after it was almost constant up to 90 hours.

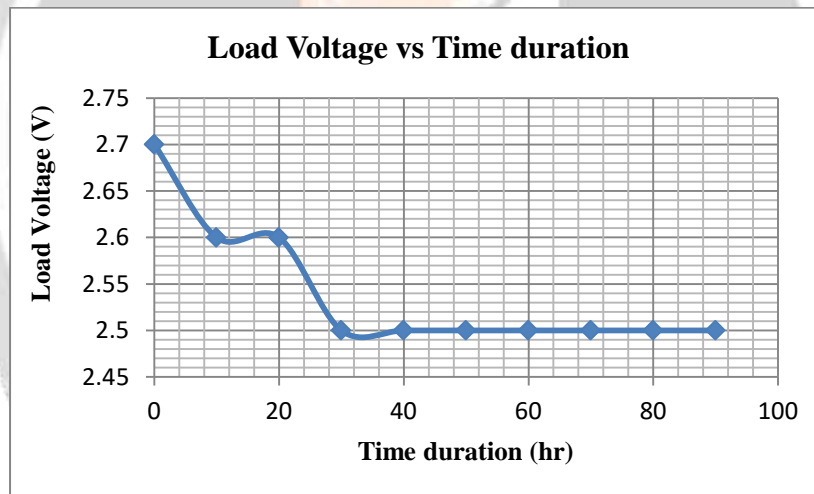

Fig.5 Load Voltage vs Time duration

Fig.5 shows the load voltage vs time duration curve. It is shown that the open circuit voltage decreases exponentially up to 20 hrs and then it decreases exponentially up to 40 hrs and then after finally it was almost constant up to 90 hours.

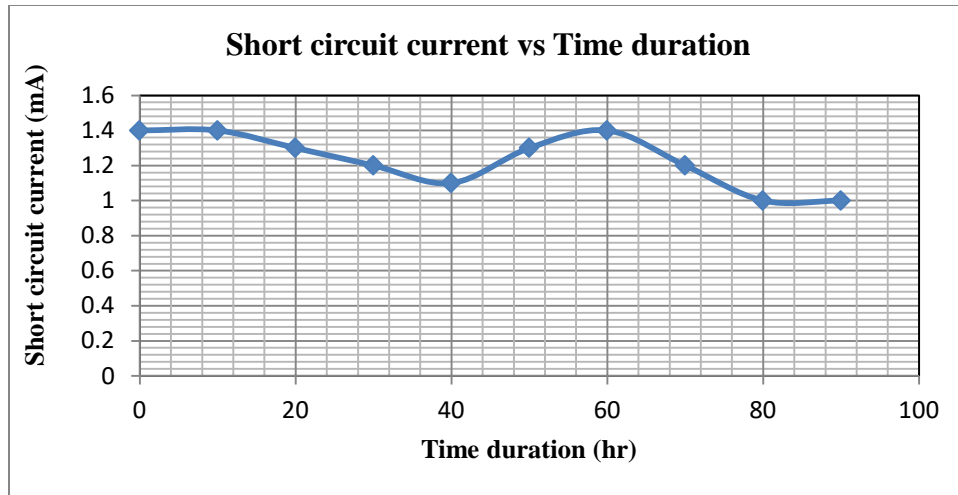

Fig.6 Short circuit current vs Time duration

Fig.6 shows the short circuit current vs time duration curve. It is shown that the short circuit current decreases up to 40 hrs and then it increase exponentially up to 80 hrs and then after finally it was almost constant up to 90 hours.

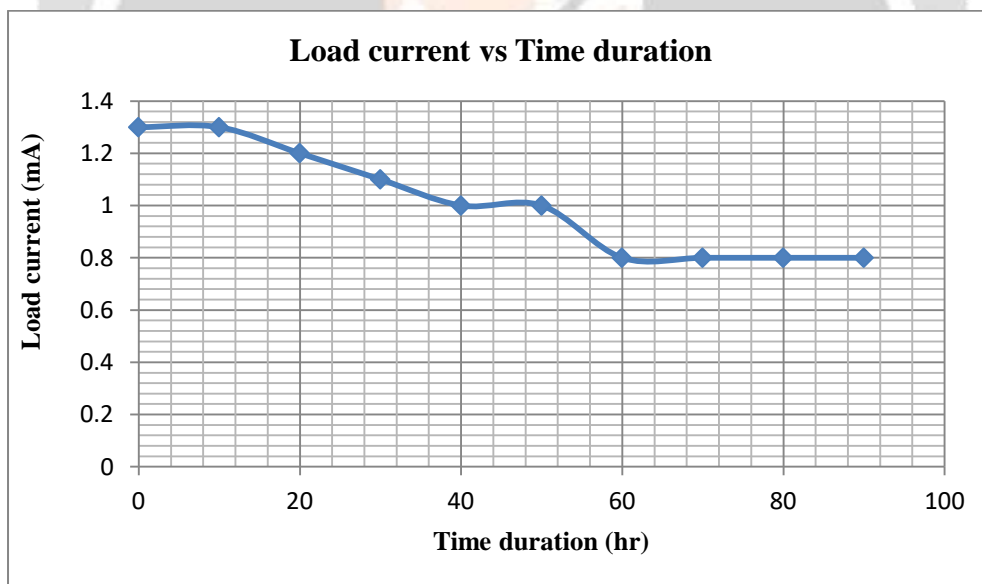

Fig.7 Load current vs Time duration

Fig.7 shows the load current vs time duration curve. It is shown that the load current decreases up to 40 hrs and then it increase exponentially up to 60 hrs and then after finally it was almost constant up to 90 hours.

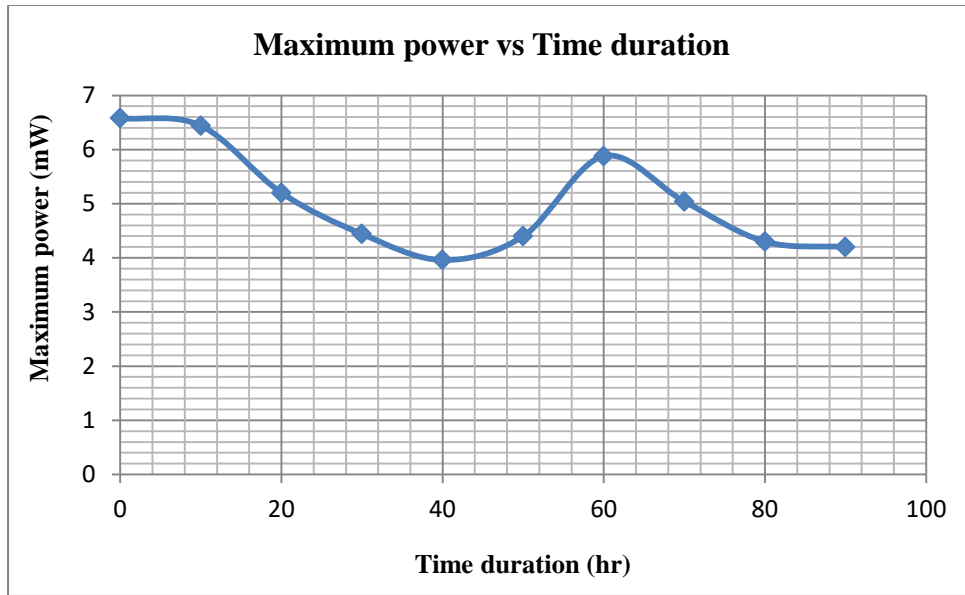

Fig.8 Maximum power vs Time duration

Fig.8 shows the maximum power vs time duration curve. It is shown that the maximum power decreases almost linearly up to 40 hrs and then it increase exponentially up to 80 hrs and then after finally it was almost constant up to 90 hours.

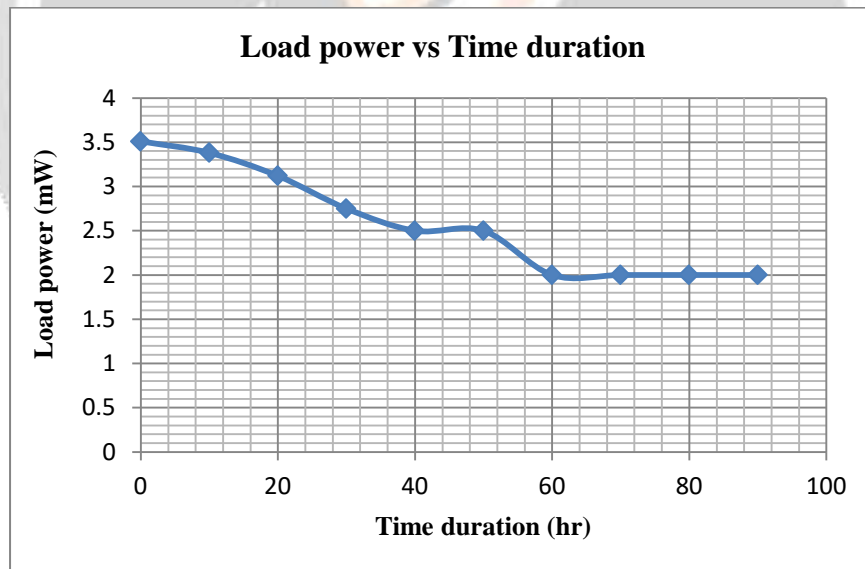

Fig.9 Load power vs Time duration

Fig.9 shows the load power vs time duration curve. It is shown that the load power decreases almost linearly up to 40 hrs and then it increase exponentially up to 60 hrs and then after finally it was almost constant up to 90 hours.

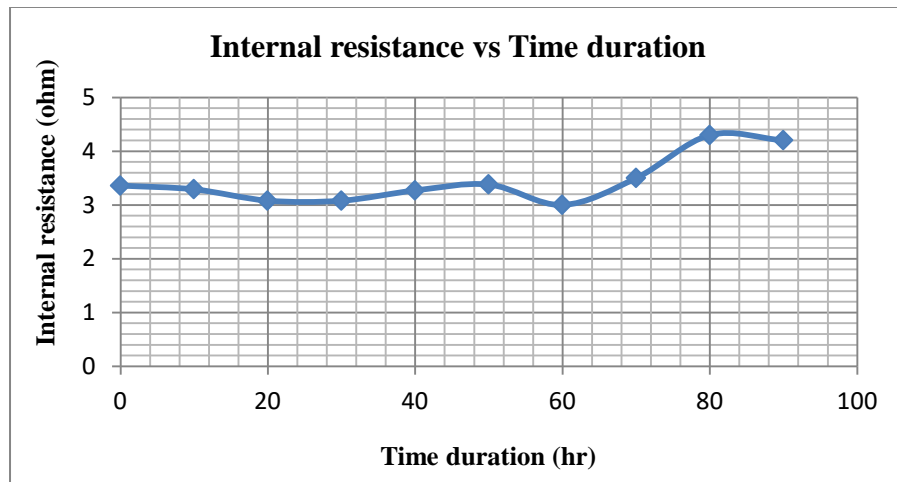

Fig.10 Internal resistance vs Time duration

Fig.10 shows the internal resistance vs time duration curve. It is shown that the internal resistances decreases almost linearly up to 30 hrs and then it increase exponentially up to 60 hrs and then after finally it increases almost exponentially up to 90 hours.

#### IV. Conclusions:

In this experiment no secondary salt was used. It needs to do further work using secondary salt. The internal resistance was relatively high. Next time internal resistance has to measure for secondary salt as comparative study.

#### References

1. Khan KA (1999) Copper oxide coatings for use in a linear solar Fresnel reflecting concentrating collector, Published in the journal. of Elsevier, Renewable Energy, An International Journal, WREN(World Renewable Energy Network), UK, RE: 12.97/859,1998, Publication date 1999/8/1, J. Renewable energy, 17( 4) :603-608. Publisher - Pergamon, 1999
2. T.A. Ruhane, M.Tauhidul Islam, Md. Saifur Rahman, M.M.H.Bhuiyah, Jahid M.M. Islam, T.I. Bhuiyah, K.A.Khan , Mubarak A. Khan (2017) Impact of photo electrode thickness annealing temperature on natural dye sensitized solar cell, Sustainable Energy Technologies and Assessments, Elsevier, <http://dx.doi.org/10.1016/j.seta.2017.01.012>
3. T.A. Ruhane, M. Tauhidul Islam, Md. Saifur Rahaman, M.M.H. Bhuiyan, Jahid M.M. Islam, M.K. Newaz, K.A. Khan, Mubarak A. Khan(2017) Photo current enhancement of natural dye sensitized solar cell by optimizing dye extraction and its loading period, Optik - International Journal for Light and Electron Optics, Elsevier
4. Mehedi Hasan & K. A. Khan (2018) Dynamic model of Bryophyllum pinnatum leaf fueled BPL cell: a possible alternate source of electricity at the off-grid region in Bangladesh, Microsystem Technologies Micro - and Nanosystems Information Storage and Processing Systems, Springer, ISSN 0946-7076, Microsyst Technol DOI 10.1007/s00542-018-4149-y
5. K. A. Khan, M. Hazrat Ali, A. K. M. Obaydullah & M. A. Wadud(2019) Production of candle using solar thermal technology, Microsystem Technologies Micro- and Nanosystems Information Storage and Processing Systems, Springer, ISSN 0946-7076, Microsyst Technol, 25(12), DOI 10.1007/s00542-019-04390-7
6. K. A. Khan, S. R. Rasel & M. Ohiduzzaman(2019) Homemade PKL electricity generation for use in DC fan at remote areas, Microsystem Technologies Micro- and Nanosystems Information Storage and Processing Systems, ISSN 0946-7076, Microsyst Technology, 25(12), DOI 10.1007/s00542-019-04422-2

7. Mehedi Hasan & Kamrul Alam Khan (2019) Experimental characterization and identification of cell parameters in a BPL electrochemical device, Springer, SN Applied Sciences (2019) 1:1008 | <https://doi.org/10.1007/s42452-019-1045-8>
8. Lovelu Hassan and K. A. Khan (2019) A study on harvesting of PKL electricity, Springer Journal, Microsyst Technol (2020) 26:1031-1041 DOI 10.1007/s00542-019-04625-7, 26(3),PP:1032-1041.
9. K. A. Khan, M. A. Mamun, M. Ibrahim, M. Hasan, M. Ohiduzzaman, A. K. M. Obaydullah, M. A. Wadud, M. Shajahan(2019) PKL electrochemical cell: physics and chemistry, Springer Journal, SN Applied Sciences (2019) 1:1335 | <https://doi.org/10.1007/s42452-019-1363-x>
10. M.Hazrat Ali, Unesco Chakma, Debashis Howlader, M. Tawhidul Islam and K.A.Khan (2019) Studies on Performance Parameters of a Practical Transformer for Various Utilizations, Microsystem Technologies, Springer, Accepted:03 Dec 2019, DOI: 10.1007/s00542-019-04711-w
11. Khan, K.A., Hassan, L., Obaydullah, A.K.M. et al. Bioelectricity: a new approach to provide the electrical power from vegetative and fruits at off-grid region. Microsyst Technol (2018). <https://doi.org/10.1007/s00542-018-3808-3>
12. Khan KA, Bhuyan MS., Mamun M A., Ibrahim M., Hasan L., Wadud M.A.( 2018), Organic Electricity from Zn/Cu-PKL Electrochemical Cell, In: Contemporary Advances in Innovative and Applicable Information Technology, Advances in Intelligent Systems and Computing, J. K. Mandal et al. (eds.), © Springer Nature Singapore Pvt. Ltd., 2018, Vol. 812, Chapter 9, p 75-90.
13. AKMAAtiqueUllah, MdMahbulHaque, MahmudaAkteer4, AHossain, ANTamanna, Md.MottalebHosen, AKMFazleKibria, MNIKhanandMKAKhan(2020)GreensynthesisofBryophyllumpinnatumaqueousleafextractmediated biomoleculcappeddiluterferromagnetic $\alpha$ -MnO<sub>2</sub> nanoparticles, Mater.Res.Express7(1)(2020),015088, IOP publishing Ltd.
14. K.A.Khan, M Hazrat Ali, M. A. Mamun, M. Mahbulul Haque, A.K.M. Atique Ullah, M.N. Islam Khan, Lovelu Hassan, A.K.M. Obaydullah, M.A.Wadud (2020), Bioelectrical Characterization and Production of Nanoparticles (NPs) Using PKL Extract for Electricity Generation, Received: 31 July 2018/Accepted: 4 February 2020, Microsystems Technology, Springer Journal, DOI 10.1007/s00542-020-04774-0.
15. Khan DMKA (2002) Prospect of Solar Energy for Food Supply in Bangladesh. Bangladesh J. of Scientific and Industrial Research BJSIR, 37(1-4)
16. Sen BK., Khan KA, Khan MAH, Awal MA(2001) Studies on Optical & thermal properties of black copper solar selective coating on copper substance. Jahang. Phys. Studs. Department of Physics, Jahangirnagar University, Savar, Dhaka, Bangladesh, Vol. 9
17. Ahsan MN, Sen BK, Khan KA & Khan MAH(1999) Performance of a Low Cost Built-in-storage Solar Water Heater. Nuclear Science and Applications, 8(1-2):
18. Khan AJ, Khan KA, Mahmood ZH & Hossain M(1991) Performance of an Intermittently Tracked Linear Solar Fresnel Reflecting Concentrator. The Dhaka University studies, part B (science) vol. 39(2):
19. Khan KA, Khan AJ & Rabbani KS (1998) Design & performance studies of a Linear Fresnel Reflecting Solar Concentrator-Receiver System, Bangladesh J.Sci. Res. 16 (2):143-146
20. Islam S, Khan KA, Islam AKS & Ali MJ(2000) Design, Fabrication & performance study of a Paraboloidal Solar Medical Sterilizer. Bangladesh J.Sci. Res. 18(2): 211-216
21. Khan MKA(1998) Solar Selective Coating for use in Solar Concentrating Collector Bangladesh J. Sci. Res. 16(2) pp: 249-252
22. Khan MKA(1999) The performance of a Fresnel Reflecting Concentrating Collector with Auxiliary Heating Bangladesh J. Sci. Ind. Res. 34(2)
23. Khan MKA(1998) Production of Candles by Solar System in Bangladesh. Nuclear Science & Applications: 7(1-2):
24. Khan MKA (1997) Field Testing of a Fresnel Reflecting Solar Concentrator, Nuclear Science & Applications. AEC, Dhanka, Bangladesh, 6(1-2):
25. Khan MKA, Khan AJ & Rabbani KS(1998) Solar Thermal Steam Production & Distillation Device by Fresnel Reflecting Concentrator – Receiver System, Bangladesh J. Sci. Res. 16(2): 221-228.
26. Khan MKA (2008) Studies on Electricity Generation from Stone Chips Plant (Bryophyllum pinnatum), Int: J.Eng. Tech 5(4): 393-397
27. Islam MS and Khan MKA (2008) Performance Studies on Single Crystal Solar PV Modules for Practical Utilisation in Bangladesh. Int: J.Eng. Tech 5(3): 348-3528
28. Khan MKA (2008) Studies on Fill Factor(FF) of Single Crystal Solar PV Modules For Use In Bangladesh. Int: J.Eng. Tech 5(3): 328-334

29. Khan MKA(2008) Performance Studies of Monocrystalline PV module considering the shadow effect. Int: J.Eng. Tech 5(3): 342-347
30. MS I and Khan MKA (2008) Study the Deterioration of a Monocrystal Solar silicon PV module Under Bangladesh Climate. Int: J.Eng. Tech 5(2):263-268
31. Hassan SJ and Khan MKA (2008) Design, Fabrication and Performance Study of a Single phase Inverter for use in Solar PV system. Int: J.Eng. Tech 5(1):212-216
32. Khan DMKA (2009) Soap Production Using Solar Power. Int: J. Eng. Tech 6(1):414-419
33. Khan DMKA (2009) Wave and Tidal Power Generation: An Overview. Int: J. Eng. Tech 6(1):420-423, March 2009
34. Khan DMKA (2009) Materials Used in Electricity Generation by Solar Thermal System
35. International J. Eng. Tech 6(1):515-520, June 2009
36. 25. Khan DMKA (2009) Comparative Study on Single Crystal and Polycrystalline solar pv modules for use in Bangladesh climate. Int: J. Eng. Tech 6(1):527-529
37. Khan DMKA (2009) Electricity Generation From Pathor Kuchi Leaf(Bryophyllum Pinnatum). Int.J.Sustain.Agril.Tech.5(7):80-84.
38. Khan DMKA (2009) Community Pathor Kuchi Leaf (PKL) Electricity Generation System. Int: J.Sustain.Agril.Tech.5(6):71-73
39. 28. Khan DMKA (2009) Solar Thermal Studies Of Open Sun Drying (OSD) of Various Crops Under Bangladesh Climatic Condition. Int: J. Sustain. Agril. Tech. 5(7): 85-94.
40. 30. Khan DMKA (2009) An Investigation on Various Solar Cells Under the Climatic Condition of Bangladesh. Int: J. Eng. Tech. 6(3): 547-551, September 2009
41. Khan DMKA and Alam MM (2010) Performance of PKL (Pathor Kuchi Leaf) Electricity and its Uses in Bangladesh. Int. J. SOC. Dev. Inf. Syst. 1(1): 15-20
42. Khan DMKA and Alam MM (2010) Comparative Study of Solar Home System and Pathor Kuchi Leaf Home System with Light Emitting Diode. Int. J. Sustain. Agril. Tech. 5(6): 74-79
43. Khan DMKA and Arafat ME (2010) Development of Portable PKL (Pathor Kuchi Leaf) Lantern. Int. J. SOC. Dev. Inf. Syst. 1(1):
44. Khan DMKA and Bosu R (2010) Performance study on PKL Electricity for Using DC Fan. Int. J. SOC. Dev. Inf. Syst. 1(1): 27-30
45. Khan DMKA and Hossain MI( 2010) PKL Electricity for Switching on the Television and Radio. Int. J. SOC. Dev. Inf. Syst. 1(1): 31-36
46. Khan DMKA and Islam MS(2010) Studies on Performance of Solar Photovoltaic System Under the Climate Condition of Bangladesh. Int: J. SOC. Dev. Inf. Syst. 1(1): 37-43
47. Khan KA , Wadud MA, Obaydullah AKM and Mamun MA(2018) PKL (Bryophyllum Pinnatum) electricity for practical utilization. IJARIE-ISSN(O)-2395-4396, 4(1): 957-966
48. Khan DMKA (2009) Application of Solar Thermal Technology for Various Developing Countries. Int: J. Eng. Tech. 6( 6):
49. Saifuddin SM & Khan DMKA(2010) Performance Study of Hybrid SPV, ST and BPL/PKL electricity Generation and storage for Practical Utilization in Bangladesh. Int: J. Eng. Tech : ISSN 1812 – 7711, 7(2)
50. Saifuddin SM & Khan DMKA(2010) Survey of Hybrid Solar Photovoltaic (SPV) and Solar Thermal (ST) Collectors in Bangladesh. Int: J. Eng. Tech : ISSN 1812 – 7711, 7(3)
51. Saifuddin SM & Khan DMKA(2010) Performance Study of Solar Photovoltaic and Solar Thermal Hybrid System Utilized in India. Int: J. Soc. Dev. Inf. Syst. 1 (4) : 10 – 16
52. Khan DMKA(2010) Organic Electricity Generation, Storage and Utilization by PKL (Bryophyllum Pinnatum). Int: Journal of Social Development and Information system( IJSDIS).1(6):
53. Sultana J, Khan KA and Ahmed MU(2010) Present situation of Solar Photovoltaic System in different countries. ASA University Review, 4(2) ISSN:1997-6925
54. Rahman AA and Khan PDMKA (2011) The Present situation of the Wave energy in some different countries of the world. IJCIT, ISSN 2078 5828(print),ISSN 2218-5224(online),2(1) Manuscript code:110754
55. Hasnat A,Ahmed P,Rahman M and Khan KA(2011) Numerical Analysis for Thermal Design of a Paraboloidal Solar Concentrating Collector. Int: Journal of Natural Sciences(2011),1(3): 68-74
56. Khan PDMKA & Rubel AH(2011) Simulated Energy Scenarios of the Power Sector in Bangladesh. ASA University Review, 5(2): 101-110, ISSN:1997-6925
57. Sultana J, Khan KA and Ahmed MU(2011) Studies on Hybrid Pathor Kuchi Leaf (PKL)/Bryophyllum Pinnatum Leaf(BPL) and Solar Photovoltaic Electricity Generation. J.Asiat.Soc.Bangladesh.Sci.,37(2):181-188,



58. Sultana J, Khan KA and Ahmed MU(2011) Electricity Generation from Pathor Kuchi Leaf(Bryophyllum Pinnatum). *J.Asiat.Soc.Bangladesh.Sci.*,37(2):167-179
59. Rashid MA, Rashed-Al-Mamun RA, Sultana J, Hasnat A, Rahman M and Khan KA (2012) Evaluating the Solar Radiation System under the Climatic Condition of Bangladesh and Computing the Angstrom Coefficients, *International Journal of Natural Sciences* . 2(1):38- 42. Received: November 2011, Accepted: March 28, 2012.
60. Sultana J, Khan KA and Ahmed MU(2012) The Present Situation of Solar Thermal Energy in the World. *ASA University Review*, 4(2), ISSN:1997-6925
61. Paul S, Khan KA, Islam KA, Islam B and Reza MA(2012) Modeling of a Biomass Energy based (BPL) Generating Power Plant and its features in comparison with other generating Plants. *IPCBE* vol. 44 (2012) @ (2012) IACSIT Press, Singapore, DOI: 10.7763/ IPCBEE. 44(3):
62. Khan DMKA, Paul S, Zishan SR, Abidullah M, Mahmud S(2012) Design of a Hybrid Model of BPL Electricity Module and Solar Photovoltaic Cell. *Int: J. of Sci. Eng. Research*. 3(12), ISSN 2229-5518.
63. Khan DMKA, Paul S, Zishan SR, Abidullah M, Mahmud S(2012) A Study on Tidal Power Conversion for Use in Bangladesh. *Int: J. of Sci. Eng. Research*. 3(12), ISSN 2229-5518.
64. Bhuiyan MSA, Khan KA and Javed MA(2012) A Computerized study on the metrological parameter conversions for rural agribusiness development. *J.of Innovation & Development Strategy (JIDS) (J. Innov. Dev. Strategy) J. Innov. Dev. Strategy* 6(2):94-98
65. Khan DMKA, Paul S, Zobayer A, Hossain SS(2013) A Study on Solar Photovoltaic Conversion. *Int:J. of Sci. and Eng. Research* , 4(3), ISSN2229-5518
66. Khan DMKA , Shuva Paul, Abdullah M, Sifat SM and Yousufe MR (2013) Performance Analysis of BPL/PKL Electricity Module. *Int:J. of Sci. and Eng. Research*, 4(3),ISSN2229-5518
67. Khan DMKA , Paul S, Zobayer A, Hossain SS(2013) A Study on Solar Thermal Conversion. *Int:J. of Sci. and Eng. Research*, 4(3),ISSN2229-5518
68. Bhuiyan MSA and Khan KA(2013) Software Development Studies on the Metrological Conversions for Local Agri-Business Units of Area and Volume Weight Measures. *J. of Innovation & Development Strategy (JIDS), Canada*, 7(1): ISSN 1997-2571
69. Ahsan MM, Kumar S, Khan MKA, Khanam MN, Khatun R, Akter S, Aheikh MAR, Islam MM, Islam MS, Saha S and Alam MM(2013) Study of Spatial Resolution of a Positron Emission Tomography(PET) System. *Jagannath University Journal of Science*, 2(1),ISSN 2224 – 1698.
70. Paul S, Khan KA and Asaduzzaman (2013) A Analytical Study on Electro chemistry for PKL (Pathor Kuchi Leaf) Electricity Generation System. Published in the Proceedings of IEEE, ENERGYTECH 2013, USA. [Participated and Presented in the “EnergyTech2013Conference sponsored by the Institute of Electrical and Electronic Engineers(IEEE) at Case Western Reserve University in Cleveland, Ohio, USA, 21 May - 23 May, 2013, USA.]
71. Paul S, Khan KA and Kundu RK(2013) Design, Fabrication and Performance Analysis of Solar Inverter. Published in the Proceedings of IEEE, ENERGYTECH 2013, USA. [Participated and Presented in the “EnergyTech2013Conference sponsored by the Institute of Electrical and Electronic Engineers(IEEE) at Case Western Reserve University in Cleveland, Ohio, USA, 21 may-23 May ,2013, USA.]
72. Paul S, Khan KA and Ripon Kumar Kundu RK (2013) Performance Studies of Mono-Crystal Silicon Solar Photovoltaic module with booster reflector under Bangladeshi Climatic condition. Published in the Proceedings of IEEE, ENERGYTECH 2013, USA. [Participated and Presented in the “EnergyTech2013Conference sponsored by the Institute of Electrical and Electronic Engineers(IEEE) at Case Western Reserve University in Cleveland, Ohio, USA, 21 May-23 May ,2013, USA.]
73. Rahman AA and Khan DKA(2013) Feasibility Studies on WEC (Wave Energy Converter) for use in Coastal Belt at Cox’s Bazar of Bangladesh under the Climate Condition of the Bay of Bengal.*Int: J. of Engi. and Innovative Technology*,3660 East Bay Drive, Apartment no.116 Largo, Florida US,33771 (IMPACT FACTOR:1.895) (ISO 9001:2008 Certified)
74. Hossain M , Alam S and Khan KA( 2013) A study on low power generation from Pathor Kuchi Leaf (Bryophyllum ) for practical utilization in Bangladesh. *Int: J. of Engi. and Innovative Technology*,3660 East Bay Drive, Apartment no.116 Largo, Florida US,33771 (ISO 9001:2008 Certified)
75. Bakshi M and Khan KA(2014) “Electricity Generation from Bryophyllum Pinnatum Leaf (BPL)-An Innovative approach for both Physicist and Chemist”. *J. of Int: Organization of Sci. Research (IOSR) Review Report* (Article id: F42028)
76. Khan KA, Latif A, Alam A, Sultana J and Ali H(2014) A Study on Internal Resistance of the Pathor Kuchi Leaf (PKL) Cell. *J. of Agriculture and Environment*. 10(1):24-28.

77. Ahasan MN, Quadir DA, Khan KA and Haque MS (2014) Simulation of a thunderstorm event over Bangladesh using wrf-arw model. *J. of Mechanical Engineering*, 44(2) Transaction of the Mechanical Engineering Division, The Institute of Engineers, Bangladesh.
78. Khan KA, Sultana J, Latif MA, Mamun MA and Saime MA (2014) A new approach of increasing the power output of Pathor Kuchi Leaf (PKL) Cell. *Journal of Agriculture and Environment*.10(2):15-19
79. Kahn MKA, Bakshi MH, Mahmud AA (2014) Bryophyllum Pinnatum leaf (BPL) is an eternal source of renewable electrical energy for future world. *J. of American Journal of Physical Chemistry*3(5):77-83, Published online November 10, 2014(<http://www.sciencepublishinggroup.com/j/ajpc>) doi:10.11648/j.ajpc.20140305.15 ISSN: 2327-2430 (Print); ISSN: 2327-2449 (Online)
80. Uddin MK, Khan MKA, Sobhan MA, Ahmed F and Nabi MN(2015) On the Implications of Dynamic Wireless Spectrum Management Canons Issues in Uncertainty Use of Cognitive Radio Published in the journal of the Bangladesh Electronics Society Journal (BESJ),15(1-2):17-24
81. Uddin MK, Khan MKA, Ahmed F and Nabi MN(2015) A Concept of Potential Radio Spectrum Administration Seeking Easy Access Spectrum (EAS) Paradigm Figured on Signal to Interference Noise Ratio (SINR) and Interference Thresholds. *J. of the Bangladesh Journal of Scientific and Industrial Research*, 2015 (in Review).
82. Uddin MK, Khan MKA, Sobhan MA, Ahmed F and Nabi MN(2015) Dispensation of Commons Radio Spectrum Management Framework Issues in Implementation: Challenges and Opportunities. *J. of Electronic Engineering*, 2015 (in Review)
83. Uddin MK, Khan MKA, Sobhan MA, Ahmed F and Nabi MN(2015) Dispensation of Commons Radio Spectrum Management Using Conceptual Benefit and Cost Analysis Framework Issues in Bangladesh. *J. of the Chittagong University Journal of Science*, 2015 (in Press)
84. Shamsuzzama M, Sikder S, Siddiqua T, Rahman MS, Bhuiyan MMH, Khan KA, and Paul D(2015) Standardization of Gamma Radiation Field for Characterizing Radiation Detecting Instrument at SSDL facilities in Bangladesh. *J. of the Bangladesh Journal of Physics (BJP)*,18: 65-72, ISSN No.: 1816-1081, BPS.
85. Kabir MU, Sobhan MA, Khan MKA, Khan MAR(2015) Broad Network Wide Statistics of TCP Indicator Measurements to Reassume the Status of the Wireless 3G Network Monitoring. *Journal of the University of Information Technology and Sciences (UITS) Journal*. 4(2), ISSN: 2226-3128
86. Khan KA, Islam F, Guha B, Hassan ML and Mostofa MM (2015) Studies on Discharge Characteristics and Temperature effect of PKL (Pathor Kuchi Leaf) Cell. *J. of “ Bangladesh J. of Agriculture and Environment”*. 11(2):07-12
87. Sruti RN, Islam MM, Rana MM, Bhuiyan MMH, Khan KA, Newaz MK and Ahmed MS (2015) Measurement of Percentage Depth of a Linear Accelerator for 6 MV and 10 MV Photon Energies.*J. of Nuclear Science and Applications, AEC, Dhaka, Bangladesh*, 24(1-2):29-32.
88. Uddin MK, Sobhan MMA, Ahmed F, Khan MKAK and Nabi MN(2025) A potential Electrical and Electronic Debris Management Model and Ecological Impact and Awareness Issues in Bangladesh. *Journal of the National University J. of Science*. 2(1), ISSN: 1994-7763
89. Akter T, Rubel A, Ahsan M, Mamun MA and Khan KA (2016) A Comparative study on PKL (Bryophyllum Pinnatum), Aloe Vera, Lemon and Tomato juice for Electricity Generation, *Int: J. of Sci. and Eng. Research (IJSER) - ISSN 2229-5518* 7(11):
90. Hasan MM, Khan DMKA, Rahman MN and Islam MZ (2016) Sustainable Electricity Generation at the coastal areas and the Islands of Bangladesh Using Biomass Resource. *J. of City University*, 2(1): pp 09-13
91. Kabir MU, Ahmed F, Sobhan DMA and Khan MKA(2016) Dispensation of Commons Radio Spectrum Management Framework Issues in Implementation: Challenges and Opportunities. *J. of the Bangladesh Electronic Society (BES)*, (ISSN: 1816-1510), 16(1-2):
92. Khan MKA, Paul S, Rahman MS, Kundu RK, Hasan MM, Muniruzzaman M and Mamun MA(2016) A study of performance analysis of PKL electricity generation parameters:(An experimental analysis on voltage regulation, capacity and energy efficiency of pathor kuchi leaf (PKL) electricity cell). *Power India International Conference (PIICON)*, 7th, 25-27 Nov. 2016, IEEE , Bikaner, Rajasthan, India.
93. Khan KA, Alam MS, Mamun MA, Saime MA & Kamal MM(2016) Studies on electrochemistry for Pathor Kuchi Leaf Power System, *J. of Bangladesh J. Agric. And Envirin*. 12(1): 37-42
94. Akter T, Bhuiyan MH, Khan KA and Khan MH(2017) Impact of photo electrode thickness and annealing temperature on natural dye sensitized solar cell. *J. of Elsevier. Ms. Ref. No.: SETA-D-16-00324R2*

95. Khan MKA(2017) Performance evaluation of Vegetative and fruits Zn/Cu based electrochemical cell. Abstract published and Presented in the APS April meeting, January 28-31,2017, Session T1(Page No.: 200), Washington DC, USA. Bulletin of the American Physical Society, 62(1):
96. Khan MKA(2017) Performance of electricity generation from Bryophyllum Leaf for Practical Utilization, Abstract published and Presented in the APS April meeting, January 28-31,2017, Session T1(Page No.: 201), Washington DC, USA. Bulletin of the American Physical Society. 62(1):
97. Mamun MA, Khan MI, Khan MKA, Shajahan M(2017) A study on the Performance and electrochemistry of Bryophyllum Pinnatum Leaf (BPL) electrochemical cell. Abstract published and Presented in the APS April meeting, January 28-31,2017, Session T1(Page No.: 201), Washington DC, USA. Bulletin of the American Physical Society, 62(1):
98. Khan KA, Alam MS ,Rahman M, Mamun MA and Kamal MM(2017) Studies on energy efficiency for PKL (Pathor Kuchi Leaf) Power System. Bangladesh J. of Agriculture and Environment. Paper Code: BJA/E/15/280
99. Khan KA, Hasan L and Islam A(2017) Electricity Production from Vegetative and fruits. 4th Int: conference on Microelectronics, Circuits and Systems, June 3rd - 4th ,2017, Darjeeling, West Bengal, India.
100. Hasan M, Khan KA and Mamun MA(2017) An Estimation of the Extractable Electrical Energy from Bryophyllum pinnatum Leaf. American Int: J.of Research in Science, Technology, Engineering & Mathematics,ISSN (Print): 2328-3491, ISSN (Online): 2328-3580, ISSN (CD-ROM): 2328-3629
101. Hasan M, Hassan L, Haque S, Rahman M, Khan KA(2017) A study to analyze the self-discharge characteristics of Bryophyllum pinnatum leaf fueled bpl test cell. J.of IJRET, 6(8):
102. Asrafusjaman M, Akter T, Hasan M, Mamun MA and Khan KA (2017) A Comparative study on the Effect of Sodium Chloride as a Secondary Salt use in PKL(Scientific name- Bryophyllum pinnatum) and Lemon Juice for Electricity Generation. Thirty-Second Int: Conference on Solid Waste Technology and Management , Philadelphia, PA U.S.A
103. Ruhane TA, M. Islam MT, Rahaman MS, Bhuiyan MMH, IslamJMM , Newaz MK, Khan KA, Khan MA(2017) Photo current enhancement of natural dye sensitized solar cell by optimizing dye extraction and its loading period. J. of Elsevier Optik- Int: J. for Light and Electron Optics, Available online 6 September 2017
104. Khan KA, and Hossain MS( 2017) Development of 1 KW PKL mini power plant for practical utilization at the off-grid region. National conference (2 days) on Science, Technology & Environment: Prospects and Limitations in the 21st Century(NCSTEPL-2017),Organised by Venue: (B.B Engg College, Assam) Bineswar Brahma Engineering College (A Govt of Assam Institution), Chandrapara, Kokrajhar-783370, Assam, (30 & 31 October)
105. Hasan M, Hassan L, Haque S, Rahman M, Khan KA(2017) A Study to Analyze the Self-Discharge Characteristics of Bryophyllum Pinnatum Leaf Fueled BPL Test Cell. Journal of IJRET, 6 (12 ): (with paper id 20170609104.)
106. Hasan M, Haque S, & Khan KA (2016) An Experimental Study on the Coulombic Efficiency of Bryophyllum pinnatum Leaf Generated BPL Cell. IJARIE-ISSN(o)-2395-4396,2(1):
107. Khan MKA ; Rahman MS ; Das T; Ahmed MN; Saha KN; Paul S( 2017) Investigation on parameters performance of Zn/Cu electrodes of PKL, AVL, Tomato and Lemon juice based electrochemical cells: A comparative study. Published in the Electrical Information and Communication Technology (EICT), 2017 3rd International Conference on IEEE Xplore: 01 February 2018, DOI: 10.1109/EICT.2017.8275150 Publisher: IEEE Conference Location: Khulna, Bangladesh.
108. Hossain MA, Khan MKA, Quayum ME( 2017) Performance development of bio-voltaic cell from arum leaf extract electrolytes using zn/cu electrodes and investigation of their electrochemical performance. Int:l J. of Advances in Science Engineering and Technology, ISSN: 2321-9009, 5(4):, Spl. Issue-1 Nov.-2017.
109. Hassan SJ & Khan KA (2007) Determination of Optimum Tilt angles of Photovoltaic panels in Dhaka, Bangladesh. Int: J. Eng. Trach 4 (3): 139-142
110. Khan MKA,Rahman MS, Das T,Saha KN and Mamun MA(2018) Investigate the Cell efficiency Of PKL Cell. Published in the Int: Conference on Electrical, Electronics, Computers, Communication, Mechanical and Computing (EECCMC) 28th & 29th January 2018 Priyadarshini Engineering College, Chettiyappanur, Vaniyambadi - 635751, Vellore District, Tamil Nadu, India.Paper Code: 01-2018-1158
111. Khan MKA and A K M Obaydullah AKM (2018) Construction and Commercial Use of PKL Cell. Published in the IJARIE-ISSN(O)-2395-4396, 4(2):3563-3570
112. Khan MKA , Obaydullah AKM, Wadud MA and Hossain MA (2018)Bi-Product from Bioelectricity. IJARIE-ISSN(O)-2395-4396, 4(2): 3136-3142

113. Khan KA, Wadud MA, Hossain MA and Obaydullah AKM (2018) Electrical Performance of PKL (Pathor Kuchi Leaf) Power. IJARIE-ISSN(O)-2395-4396, 4(2):3470-3478
114. Khan KA, Hossain MA, Obaydullah AKM and Wadud MA(2018) PKL Electrochemical Cell and the Peukert's Law. IJARIE-ISSN(O)-2395-4396, 4(2):4219-4227
115. Khan KA, Ali MH, Mamun MA, Haque MM, Ullah AKMA, Dr. Mohammed Nazrul Islam Khan DMNI, Hassan L, Obaydullah AKM, Wadud MA(2018) Bioelectrical Characteristics of Zn/Cu- PKL Cell and Production of Nanoparticles (NPs) for Practical Utilization. 5th Int: conf. on 'Microelectronics, Circuits and Systems', Micro2018, 19th and 20th May, 2018, Venue: Bhubaneswar, Odisha, India, Organizer: Applied Computer Technology, Kolkata, West Bengal, India, Page: 59-66, www.actsoft.org, ISBN: 81-85824-46-1, In Association with: International Association of Science, Technology and Management.
116. Hassan MM, Arif M and Khan KA (2018) Modification of Germination and growth patterns of Basella alba seed by low pressure plasma. Journal of Modern Physics, 5(3), pp:17-18
117. Khan KA, Manir SMM, Islam MS, Jahan S, Hassan L, and Ali MH(2018) Studies on Nonconventional Energy Sources for Electricity Generation. Int: J. Of Advance Research And Innovative Ideas In Education. 4(4): 229-244
118. Khan KA, Hasan M, Islam MA, Alim MA, Asma U, Hassan L, and Ali MH (2018) A Study on Conventional Energy Sources for Power Production. Int: J. Of Advance Research And Innovative Ideas In Education. 4 (4) : 229-244
119. Khan KA, Rahman MS, Paul S(2017) Investigation on parameters performance of Zn/Cu electrodes of PKL, AVL, Tomato and Lemon juice based electrochemical cells: A comparative study. Publication Year: 2017, Page(s):1-6, Published in: 2017 3rd International Conference on Electrical Information and Communication Technology (EICT), Date of Conference: 7-9 Dec. 2017, Date Added to IEEE Xplore: 01 February 2018, ISBN Information: INSPEC Accession Number: 17542905, DOI: 10.1109/EICT.2017.8275150, Publisher: IEEE, Conference Location: Khulna, Bangladesh 2018
120. Khan PDMKA(2018) An Experimental Observation of a PKL Electrochemical Cell from the Power Production View Point. Presented as an Invited speaker and Abstract Published in the Conference on Weather Forecasting & Advances in Physics, Department of Physics, Khulna University of Engineering and Technology (KUET), Khulna, Bangladesh. 2018
121. Guha P, Islam F and Khan KA(2018) Studies on Redox Equilibrium and Electrode Potentials. IJARIE-ISSN(O)-2395-4396, 4(4):1092-1102, 2018
122. Islam F, Guha P and Khan KA(2018) Studies on pH of the PKL Extract during Electricity Generation for day and night time collected Pathor Kuchi Leaf, IJARIE-ISSN(O)-2395-4396, 4(4):1103 -1113
123. Hassan SJ & Khan KA (2007) Design, Fabrication and performance study of Bucket type solar candle machine. Int: J. Eng. Trach 4 (3):
124. MAH Khan & Khan DMKA(2005) Selective Black - Nickel coating for use in linear Fresnel Reflecting concentrating collector. Nuclear science and Applications. 14(11) :
125. Khan KA, Rahman ML, Islam MSI, Latif MA, Hossain MA, Saime MA and Ali MH (2018) Renewable Energy Scenario in Bangladesh. J. of IJARII, 4(5) : 270-279, ISSN(O)-2395-4396.
126. Khan KA and Rasel SR (2018) Prospects of Renewable Energy with Respect to Energy Reserve in Bangladesh Published in the journal of IJARII. ISSN(O)-2395-4396. 4(5):280-289
127. Khan KA, Hossain MS, Kamal MM, Rahman MA and Miah I (2018) Pathor Kuchi Leaf : Importance in Power Production. IJARIE-ISSN(O)-2395-4396 , 4(5):
128. Khan KA, Ali MH, Mamun MA, Ibrahim M, Obaidullah AKM, M. Hossain A and Shahjahan M(2018) PKL Electricity in Mobile Technology at the off-grid region. Published in the proceedings of CCSN-2018, 27-28 October, 2018 at Kolkata, India.
129. Khan KA and Hossain A (2018) Off-grid 1 KW PKL Power Technology: Design, Fabrication, Installation and Operation Published in the proceedings of CCSN-2018, 27-28 October, 2018 at Kolkata, India.
130. Khan KA, Mamun MA, Ibrahim M, Hasan M, Ohiduzzaman M, Obaidullah AKM, Wadud MA and Shahjahan M (2018) PKL electrochemical cell for off-grid Areas: Physics, Chemistry and Technology Published in the proceedings of CCSN-2018, 27-28 October, 2018 at Kolkata, India. 2018
131. Khan KA, and Rasel SR (2018) Studies on Wave and Tidal Power Extraction Devices. Int: J. Of Advance Research And Innovative Ideas In Education. 4(6):61-70
132. Khan KA, Ahmed SM, Akhter M, Hossen MRAM (2018) Wave and Tidal Power Generation. Int: J. Of Advance Research And Innovative Ideas In Education. 4(6):71-82
133. Khan KA, Rahman MA, Islam MN, Akter M, and Islam MS(2018) Wave Climate Study for Ocean Power Extraction. Int: J. Of Advance Research And Innovative Ideas In Education. 4(6 ):83-93

134. Khan KA, Miah MS, Ali MI, Sharma KS, and Quader A(2018) Studies on Wave and Tidal Power Converters for Power Production. Int: J. Of Advance Research And Innovative Ideas In Education. 4(6):94-105
135. Khan KA, Ali MH, Obaydullah AKM, Wadud MA( 2018) Candle Production Using Solar Thermal Systems.1st Int: Conference on 'Energy Systems, Drives and Automations', ESDA2018, Page: 55-66.
136. Khan KA, Rasel SR and Ohiduzzaman M(2018) Homemade PKL Electricity Generation for Use in DC Fan at Remote Areas.1st Int: Conference on 'Energy Systems, Drives and Automations', ESDA2018, Page: 90-99.
137. Khan KA and Yesmin F (2019) PKL Electricity- A Step forward in Clean Energy. Int:J. Of Advance Research and Innovative Ideas In Education. 5 ( 1): 316-325
138. Khan KA and Yesmin F(2019) Cultivation of Electricity from Living PKL Tree's Leaf. Int: J. Of Advance Research And Innovative Ideas In Education. 5 (1):462-472
139. Khan KA and Yesmin F(2019) Solar Water Pump for Vegetable field under the Climatic Condition in Bangladesh. Int: J. Of Advance Research And Innovative Ideas In Education. 5 (1):631-641
140. Khan KA, Rasel SR and Ohiduzzaman M(2019) Homemade PKL Electricity Generation for Use in DC Fan at Remote Areas.Accepted and is going to be published in Microsystem Technologies, Springer, MITE-D-19-00131, 27 February, 2019.
141. Khan KA, Ali MH, Obaydullah AKM, Wadud MA (2019) Production of Candle Using Solar Thermal Technology. Accepted and is going to be published in Microsystem Technologies, Springer, MITE-D-1900119-, 04 March, 2019.
142. Khan KA , and Rasel SR(2019) Solar Photovoltaic Electricity for Irrigation under Bangladeshi Climate. Int: J. Of Advance Research And Innovative Ideas in ducation. 5 (2): 28-36
143. Khan KA and Rasel SR(2019) The Present Scenario of Nanoparticles in the world. Int: J. Of Advance Research And Innovative Ideas In Education. 5 (2):462-471
144. Khan KA, Yesmin F, Wadud MA and Obaydullah AKM (2019) Performance of PKL Electricity for Use in Television. Int: Conference on Recent Trends in Electronics & Computer Scienc-2019, Venue: NIT Silchar, Assam, India. Conference date: 18th and 19th of March, 2019. Organizer: Department of Electronics and Engineering, NIT Silchar, Assam, India. Page: 69
145. Mamun MA, Ibrahim M and Shahjahan M and Khan KA (2019) Electrochemistry of the PKL Electricity.Int: Conference on Recent Trends in Electronics & Computer Scienc-2019, Venue: NIT Silchar, Assam, India, Conference dates: 18th and 19th of March, 2019. Organizer: Department of Electronics and Engineering, NIT Silchar, Assam, India. Page: 71
146. Khan KA, Hossain MA , Kabir MA, Rahman MA and Lipe P(2019) A Study on Performance of Ideal and Non-ideal Solar Cells under the Climatic Situation of Bangladesh. Int:J. Of Advance Research And Innovative Ideas in Education.5(2): 975-984
147. Khan KA (1999) Copper oxide coatings for use in a linear solar Fresnel reflecting concentrating collector, Publication date 1999/8/1, J. Renewable energy, 17( 4) :603-608. Publisher – Pergamon, 1999
148. Ohiduzzaman M, Khan KA, Yesmin F and Salek MA (2019) Studies on Fabrication and Performance of Solar Modules for practical utilization in Bangladeshi Climate. IJARIE, 5(2): 2626-2637
149. K.A.Khan and Salman Rahman Rasel (2019) A study on electronic and ionic conductor for a PKL electrochemical cell, IJARIE, 5(2): 3100-3110.
150. M Ohiduzzaman, R Khatun, S Reza, K A Khan, S Akter, M F Uddin, M M Ahasan (2019) Study of Exposure Rates from various Nuclear Medicine Scan at INMAS, Dhaka. IJARIE, 5(3): 208-218
151. K.A.Khan and Salman Rahman Rasel(2019) Development of a new theory for PKL electricity using Zn/Cu electrodes: per pair per volt, IJARIE, 5(3):1243-1253
152. K.A. Khan & M. Abu Salek(2019) A Study on Research, Development and Demonstration Of Renewable Energy Technologies, IJARIE, 5(4):113-125
153. K.A. Khan, Mohammad Nazim Uddin, Md. Nazrul Islam, Nuruzzaman Mondol & Md.Ferdous(2019) A Study on Some Other Likely Renewable Sources for Developing Countries, IJARIE, 5(4):126-134
154. Hasan,M.& Khan, K.A. (2019) Experimental characterization and identification of cell parameters in a BPLElectrochemicaldevice.SN Appl.Sci.,1:1008.<https://doi.org/10.1007/s42452-019-1045-8>
155. K.A. Khan & S.M. Zian Reza(2019) The Situation of Renewable Energy Policy and Planning in Developing Countries, IJARIE, 5(4):557-565
156. K.A. Khan & M. Abu Salek (2019) Solar Photovoltaic (SPV) Conversion: A Brief Study, IJARIE, 5(5):187-204
157. K.A.Khan, Nusrat Zerin , S.M.Noman Chy.,M.Nurul Islam, Ruchi Bhattacharjee(2019) A study on voltage harvesting from PKL living plant, IJARIE, 5(5): 407-415

158. K.A. Khan, M.A. Mamun, M. Ibrahim, M. Hasan, M. Ohiduzzaman, A.K.M. Obaydullah, M.A. Wadud, M. Shajahan (2019), PKL electrochemical cell: physics and chemistry, SN Applied Sciences (2019) 1:1335, <https://doi.org/10.1007/s42452-019-1363-x>
159. M. N. F. Rab, K. A. Khan, Salman Rahman Rasel, M. Ohiduzzaman, Farhana Yesmin, Lovelu Hassan, M. Abu Salek, S.M. Zian Reza and M. Hazrat Ali (2019) Voltage cultivation from fresh leaves of air plant, climbing spinach, mint, spinach and Indian pennywort for practical utilization, 8<sup>th</sup> international conference on CCSN2019, Vol-1, October, 19<sup>th</sup>-20<sup>th</sup>, 2019, Institute of Aeronautical Engineering, Hyderabad, India.
160. M. Hazrat Ali, Unesco Chakma, Debashis Howlader, M. Tawhidul Islam and K.A. Khan (2019) Studies on Performance Parameters of a Practical Transformer for Various Utilizations, 8<sup>th</sup> international conference on CCSN2019, Vol-1, October, 19<sup>th</sup>-20<sup>th</sup>, 2019, Institute of Aeronautical Engineering, Hyderabad, India.
161. K.A. Khan, Md. Shahariar Rahman, Ali Akter, Md. Shahidul Hoque, Md. Jahangir Khan, Eiskandar Mirja, Md. Nasiruddin Howlader, Mohammed Solaiman (2019) A study on the effect of embedded surface area of the electrodes for voltage collection from living PKL tree, 5(6), IJARIE-ISSN(O)-2395-4396
162. K.A. Khan and S.M. Zian Reza (2019) A Study on Maximum Power Harvesting Potential from living PKL tree - Future Energy Resource for the Globe, 5(6), PP:893-903, IJARIE-ISSN(O)-2395-4396
163. M. Hazrat Ali, Unesco Chakma, Debashis Howlader, M. Tawhidul Islam and K.A. Khan (2019) Studies on Performance Parameters of a Practical Transformer for Various Utilizations, Microsystem Technologies, Springer, Accepted: 03 Dec 2019, DOI: 10.1007/s00542-019-04711-w
164. K.A. Khan (2019) Impact of Electrode Surface for Voltage Cultivation from Living PKL Tree, International Journal of Nanotechnology in Medicine & Engineering, 4(5), November 2019
165. K.A. Khan and M. Abu Salek (2019), Future Trends in Vegetative and Fruits Energy- A New Renewable Energy Source for Future Electricity, IJARIE, 5(6), pp:1144-1160
166. K.A. Khan, Alamgir Kabir, Anwar Hossain, Nazmul Alam, Abhijeet Kumar Kundu, Ali Akter (2019) A comparative Study between Lead Acid and PKL Battery, IJARIE, 5(6), pp:1439-1454
167. M. K. A. Khan, A. Rahman, S. Paul, M. S. Rahman, M. T. Ahad and M. Al Mamun (2019), "An Investigation of Cell Efficiency of Pathor Kuchi Leaf (PKL) Cell for Electricity Generation," 2019 International Symposium on Advanced Electrical and Communication Technologies (ISAECT), Rome, Italy, 2019, pp. 1-6.
168. Dr. A K M Obaydullah, Dr. K.A. Khan (2020) Perception of head teachers of primary schools about quality primary science teaching-learning (TL) practice in Bangladesh, SPC Journal of Education, Science Publishing Corporation Publisher of International Academic Journals, DOI: 10.14419/je.v3i1.30593, Vol(3), No(1), Pages:18-21.
169. K. A. Khan, Md. Alamgir Kabir, Mustafa Mamun, Md. Anwar Hossain, Samiul Alim (2020), An Observation of Solar Photovoltaic Electricity across the globe, IJARIE, 6(4), pp:1487-504, ISSN(O)-2395-4396
170. Md. Kamrul Alam Khan (2020) PKL Electrochemical Cell - A New and Innovative Clean Energy Production System, Hendun Research Access, NTNS, 3(1), pp: 73-78
171. K.A. Khan, M. Shaiful Islam, M.N. Islam Khan, Atique Ullah, Shahinul Islam, S. R. Rasel (2020), Zinc Oxide Nanoparticles Production Using *Catharanthus Roseus* Leaf Extract and their Characterization for Practical Utilization, Proceeding of 7<sup>th</sup> International Conference on Microelectronics, Circuits & Systems, MICRO-2020, 25<sup>th</sup> and 26<sup>th</sup> of July, 2020. Venue: Online Conference, In Collaboration with: Delhi Technological University, Delhi, India.
172. K.A. Khan, M. Shaiful Islam, Md. Abdul Awal, M.N. Islam Khan, Atique Ullah (2020), Studies on Performances of Copper Oxide Nanoparticles from *Catharanthus Roseus* Leaf Extract, Proceeding of 7<sup>th</sup> International Conference on Microelectronics, Circuits & Systems, MICRO-2020, 25<sup>th</sup> and 26<sup>th</sup> of July, 2020. Venue: Online Conference, In Collaboration with: Delhi Technological University, Delhi, India.
173. Salman Rahman Rasel and K. A. Khan (2020), A Study on Electrochemical Cell based on soil and living PKL tree, Proceeding of 7<sup>th</sup> International Conference on Microelectronics, Circuits & Systems, MICRO-2020, 25<sup>th</sup> and 26<sup>th</sup> of July, 2020. Venue: Online Conference, In Collaboration with: Delhi Technological University, Delhi, India.
174. Lovelu Hassan & K. A. Khan (2020), Applications of PKL electricity for use in DC instruments, Proceeding of 7<sup>th</sup> International Conference on Microelectronics, Circuits & Systems, MICRO-2020, 25<sup>th</sup> and 26<sup>th</sup> of July, 2020. Venue: Online Conference, In Collaboration with: Delhi Technological University, Delhi, India.
175. K.A. Khan and Md. Abdul Awal (2020), A study on connection between chemistry and electricity, IJARIE-ISSN(O)-2395-4396, Vol-6 Issue-5 2020.

176. K.A.Khan, M.A.Mamun and Sharif Mia(2020), Electrochemical conversion of CO<sub>2</sub> into useful chemicals and PKL electricity, Abstract Published, Proceedings of 9th International Conference on Computing, Communication and Sensor Networks 17th and 18th of October, Organizer: Applied Computer Technology Kolkata, West Bengal, India. www.actsoft.org In Association with: International Association of Science, Technology and Management,Page-19, Venue: Online conference.
177. K.A.Khan and Shahinul Islam(2020), 3R economy of the PKL electrochemical cell, Abstract Published, Proceedings of 9th International Conference on Computing, Communication and Sensor Networks 17th and 18th of October, Organizer: Applied Computer Technology Kolkata, West Bengal, India. www.actsoft.org In Association with: International Association of Science, Technology and Management, Page-26 , Venue: Online conference.
- 178.K.A. Khan, and Md. Abdul Awal. "A Study on Graphite, Graphene, Graphene Oxide (GO) and Reduced Graphene Oxide (rGO) for Practical Utilization" Internation Journal Of Advance Research And Innovative Ideas In Education Volume 6 Issue 6 2020 Page 422-434
- 179.K.A. Khan, Syful islam , and Md. Abdul Awal(2020) "A historical review on silver nanoparticles (AgNPs) synthesis for different leaf, vegetative and plant extracts" Internation Journal Of Advance Research And Innovative Ideas In Education Volume 6 Issue 6 2020 Page 705-724
- 180.K.A. Khan , Shahinul Islam, S. R. Rasel, M. A.Saime, Sazzad Hossain, Md. Atiqur Rahman (2020) Erformance Evaluation Of Pkl (Pathor Kuchi Leaf) Electricity For Use In Television And Radio, Information Management and Computer Science (IMCS) 3(2) (2020) 30-37, DOI: <http://doi.org/10.26480/imcs.02.2020.30.37>
- 181.K.A. Khan, Samiul Alim, Md Khairul Islam, and Sayed Bony Amin. "Living PKL Plants - An Innovative Idea for PKL back up LED lamp along the Coastal Belts of Bangladesh" Internation Journal Of Advance Research And Innovative Ideas In Education Volume 7 Issue 2 2021 Page 112-127
182. Khan KA, Bhuyan MS., Mamun M A., Ibrahim M., Hasan L., Wadud M.A.( 2018), Organic Electricity from Zn/Cu-PKL Electrochemical Cell, In: Contemporary Advances in Innovative and Applicable Information Technology, Advances in Intelligent Systems and Computing, J. K. Mandal et al. (eds.), © Springer Nature Singapore Pvt. Ltd., 2018, Vol. 812, Chapter 9, p 75-90.
183. Kamrul Alam Khan, Salman Rahman Rasel, S.M. Zian Reza and Farhana Yesmin (March 25th 2020). Energy Efficiency and Sustainability in Outdoor Lighting - A Bet for the Future, Energy Efficiency and Sustainable Lighting - a Bet for the Future, Manuel Jesús Hermoso-Orzáez and Alfonso Gago-Calderón, IntechOpen, DOI: 10.5772/intechopen.89413. Available from:
184. K.A.Khan, Farhana Yesmin, Md. Abdul Wadud and A K M Obaydullah (2019), "Performance of PKL Electricity for Use in Television", accepted as a book chapter NAROSA publisher, September 2019.
- 
185. M. N. F.Rab, K. A. Khan, Salman Rahman Rasel, M.Hazrat Ali, Lovelu Hassan , M. Abu Salek , S.M.Zian Reza and M Ohiduzzaman(2020) "Voltage Cultivation from Fresh Leaves of Air Plant, Climbing Spinach, Mint, Spinach and Indian Pennywort for Practical Utilization", Energy Systems, Drives andAutomations, Springer Singapore, Lecture Notes in Electrical Engineering, eBook ISBN: 978-981-15-5089-8, DOI: 10.1007/978-981-15-5089-8, Hardcover ISBN: 978-981-15-5088-1, Series ISSN: 1876-1100, Volume: 664,Page: 150-160.
186. K. A. Khan, Salman Rahman Rasel, S.M.Zian Reza, M. A. Saime, Nazmul Alam, Abu Salek , MehediHasan (2020) "Solar Medical Sterilizer using Pressure Cooker for Rural off-grid Areas", Energy Systems, Drives andAutomations, Springer Singapore, Lecture Notes in Electrical Engineering, eBook ISBN: 978-981-15-5089-8, DOI: 10.1007/978-981-15-5089-8, Hardcover ISBN: 978-981-15-5088-1, Series ISSN: 1876-1100, Volume: 664,Page: 258-269.
187. K. A. Khan, M. A. Saime, M.Hazrat Ali, S. M. Zian Reza, Nazmul Alam, Md. Afzol Hossain, M. N.F.Rab and Shahinul Islam (2020) "A study on PKL electrochemical cell for three different conditions ", Energy Systems, Drives andAutomations, Proceedings of ESDA 2019 , Springer Singapore, Lecture Notes in Electrical Engineering, eBook ISBN: 978-981-15-5089-8, DOI: 10.1007/978-981-15-5089-8, Hardcover ISBN: 978-981-15-5088-1, Series ISSN: 1876-1100, Volume: 664, Page: 374-386.
188. Khan K. et al. (2020) A Study on Development of PKL Power. In: Mandal J.K., Mukherjee I., Bakshi S., Chatterji S., Sa P.K. (eds) Computational Intelligence and Machine Learning. Advances in Intelligent Systems and Computing, vol 1276. Pp151-171, Springer, Singapore. [http://doi-org-443.webvpn.fjmu.edu.cn/10.1007/978-981-15-8610-1\\_17](http://doi-org-443.webvpn.fjmu.edu.cn/10.1007/978-981-15-8610-1_17)
189. ScienceDaily, Electrical circuit runs entirely off power in trees, University of Washington, 9 September 2009.
190. C.D.D. Angel, "Introduction of Electrochemistry", Georgetown University, <http://bourman.chem.georgetown.edu/S02/lect25/lect25.htm>, Retrieved by 16 October 2012.

191. Thermo Elemental, AAS, GFAAS, ICP or ICP-MS? Which technique should I use? An elementary overview of elemental analysis, 2001.
192. M. Garg, J. Singh, "Quantitative AAS Estimation of Heavy Metals and Trace Elements in Marketed Ayurvedic Churna Preparations in India", International Journal of Pharmaceutical Science and Research, vol. 3, no. 5, pp. 1331-1336, 2012.
193. G. D. Christian, J. E. O'Reilly, Atomic Absorption Spectroscopy, 2nd ed., Instrumental Analysis, Boston: Allyn and Bacon, 1986, ch. 10.
194. K. Sukender, S. Jaspreet, D. Sneha, G. Munish "AAS Estimation of Heavy Metals and Trace elements in Indian Herbal Cosmetic Preparations", International Science Congress Association, vol. 2, no. 3, pp. 46-51, 2012.

