

# Enhancement of Security System in Elevator using RF.

Sagar Athare<sup>1</sup>, Nilesh Aamluk<sup>2</sup>, Bhupesh Gosavi<sup>3</sup>, Narendra Jamadar<sup>4</sup>, Prof. R.V.Patel.<sup>4</sup>

<sup>1</sup> Student, Department. of Electrical Engineering, SIEM, Nashik, Maharashtra, INDIA  
atharesagar@gmail.com

<sup>2</sup> Student, Department of Electrical Engineering, SIEM, Nashik, Maharashtra, INDIA  
nileshaamluk@gmail.com

<sup>3</sup> Student, Department of Electrical Engineering, SIEM, Nashik, Maharashtra, INDIA  
Bhupeshgosavi98@gmail.com

<sup>4</sup> Student, Department of Electrical Engineering, SIEM, Nashik, Maharashtra, INDIA  
Narendrrajput9689@gmail.com

<sup>5n</sup> Professor, Department of Electrical Engineering, SIEM, Nashik, Maharashtra, INDIA  
Rajankumar.patel@siem.org.in

## ABSTRACT

The elevators have become one of the most necessary parts of buildings like commercial malls, Hospitals, residential apartments, offices etc. The usual security systems adopted in conventional elevators is a CCTV camera for surveillance which is not enough for the modern world. The security implemented in this project will alert the authorized personnel in case of any emergency. In order to know the location of the elevator IR modules are used. This IR module can also be used to calculate the time taken by the elevator to reach the next floor. If the time period exceeds the limit, this indicates that the lift may have been stopped in the middle due to power failure or other issues. This circuit is also designed to detect smokes and other poisonous gasses along with the basic surveillance.

**Keyword :** - Gas sensor, IR module, GSM module, Condenser microphone.

## 1. INTRODUCTION

In last decades, technology has been improved drastically in the field of security systems. But, it is not extended to all areas especially in elevators. The advanced elevator security system is a project to ensure complete safety for the people while using the elevator. This project will provide advanced security in addition to the basic surveillance systems. This circuit is completely independent of the elevator circuit. In this paper it is introduced new surveillance system that senses voice, poisonous gasses through various sensors and alerts the controlling person through short message service. This short message service is accompanied by GSM module.

## 2. RELATED WORK

In the system uses IR sensor to sense the unauthorized person entering the home and sends SMS to the concerned personnel through a GSM module. It uses IR transmitter and receiver at each side of the door. A person entering the home will disturb the IR sensor and it triggers the GSM module for sensing the SMS. In [2], the system deals with the CCTV camera which gets triggered if any illegal entrance is found. This entrance is detected using IR

module. Once the IR module is triggered, the CCTV camera starts recording the happenings in the dedicated area followed by a SMS through GSM module. In [3], the system uses gas sensor in order to sense the smoke in case of any fire accidents. In the presence of smoke or fire, the information is sent to the server through Wi-Fi. In [4], system uses Radio Frequency for transmission and reception of the serial data. The information to be sent is converted into a series of data and transmitted through the RF transmitter. The RF receiver is used at the receiver section to receive the serial data which is further converted to the original information.

### 3. EXISTING SYSTEM

The existing system comprises of a CCTV camera integrated with the elevator control room for surveillance. A weight measuring system is used in order to know the amount of load present in the elevator. This is used to alert the passengers in case of overload. A switch is present inside the elevator for the passengers to use in case of any emergency.

Drawbacks:

The elevator may get stuck in between the floors due to power failures. Physical effort is required in order to activate the security system.

### 4. BLOCK DIAGRAM

Advanced elevator security system mainly consists of the Microcontroller 8051, gas sensor, condenser microphone, IR module and Global system for mobile communication module. GSM module is interfaced for alerting the controlling person from the client.

This circuit can be activated by four methods.

- 1) Switch: The conventional method where pressing the emergency button triggers the circuit.
- 2) Noise sensor: If the victim is in such a position that he cannot press the button, then a loud voice will activate the circuit automatically.
- 3) Gas sensor: The presence of harmful gases such as chloroform, smoke, Benzene is also an emergency situation.

IR sensor: This sensor is placed in each floor. It is used to calculate the time taken by the elevator to reach the next floor. If this time exceeds the limit, then this indicates that there is problem in the movement of elevator or the elevator is stuck between floors. This is also triggers the circuit

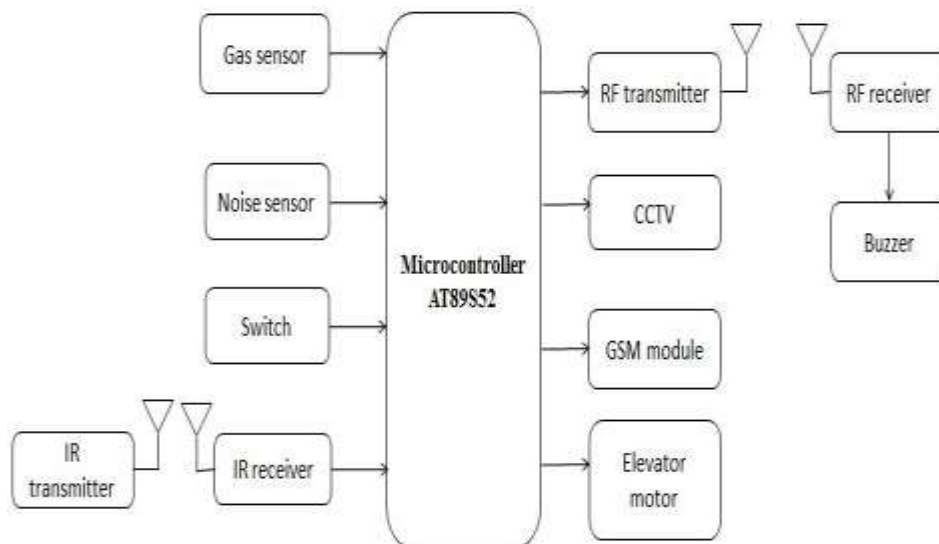

Fig 1. Block Diagram



Fig.2 RF transmitter



Fig.3 RF receiver

Once the circuit is activated, a number of parallel operations are carried out simultaneously. The Alarm will be set off throughout the building letting the people know about the emergency in the elevator. The elevator is opened in the next corresponding floor regardless of its original destination by the use of backup battery. An immediate intimation about the incident will be sent to the security personnel through GSM module.

## 5. HARDWARE REQUIREMENTS

### A. AT89S52 (Microcontroller):

The AT89S52 is a low power, high power CMOS 8 bit microcontroller with 8Kbytes of in-system programmable flash memory. The appliance is feigned using ATMEL high density non-volatile memory skill and is companionable with the industry standard 89S52 training set and pin out. The on-set flare permits the program memory to be reprogrammed in-system or by conventional non-volatile memory programmer. By combining a versatile 8-bit CPU with in-system programmable flash on a monolithic chip, the Atmel AT89S52 is a powerful microcontroller which provides a highly-flexible and cost-effective solution to many embedded control applications. The AT89S52 provides the following standard features: 8K bytes of flash, 256 bytes of RAM, 32 I/O lines, Watchdog timer, two data pointers, three 16-bit timer/counters, a Six-vector two-level interrupt architecture, a full duplex serial port, on-chip oscillator, Down to zero frequency and supports two software selectable power saving modes: Low-power Idle and power down Modes. The sensors and other components are integrated to this microcontroller. The components used in this circuit are Gas sensor, Condenser Mic, GSM Module, IR Module and an RF Module for connecting the buzzer with the input.

### B. RF Module:

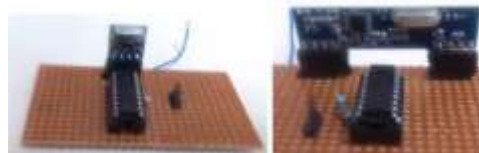

Fig.4 RF transmitter and Receiver

The RF module is an electronic used to transmit and/or receive radio signal between two devices. This RF module pair operates at the frequency of 434MHz and the range is 500ft. The RF transmitter receives serial data from the encoder HT12E (fig.2) and transmits it wirelessly through Radio Frequency by its antenna. The transmission occurs

at the range of 1Kbps to 10Kbps. The transmitted data is received by the RF receiver operating at the same frequency as that of the transmitter and it is changed to the parallel data using HT12D.

### C. MQ-6 (Gas sensor):

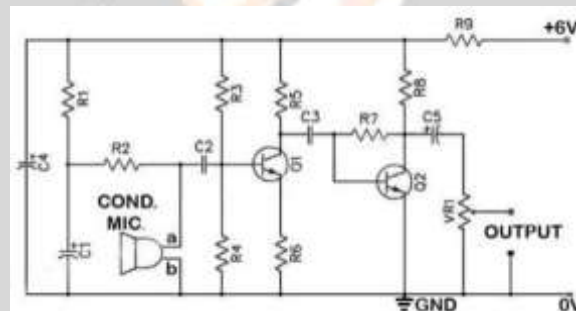

*Fig.6 Gas sensor Inetrfacing*

MQ-6 gas sensor modules are used in detecting the presence of gases in an area, space often as part of a safety system. This type of equipment is used to detect the smoke and interface with a microcontroller a process can be automatically shut down. This type of module is important because there are many gases that are harmful to life. A dedicated voltage comparator chip LM234 is designed to interface with the analog output of the gas sensor.

### D. Condenser Microphone:

Fig.7 shows the sound sensor circuit using 2-pin condenser microphone



*Fig.7 Sound sensor*

A condenser microphone is a device used to convert the audio signals into voltage signals. This voltage signal is directly proportional to the level sound produced (i.e. decibel level). Thus by measuring the decibel level we can identify whether a person is shouting or talking normally.

### E. GSM Module (SIM 900)

GSM is to be referred as Global System for Mobile Communication. It is of various types such as SIM (300), SIM (900), SIM (1200) etc. In this system it is used for home automation system. Basically it is used for sending messages. When an emergency situation occurs in the elevator, it sends SMS to the security personnel regarding the emergency situation.

## 6. SOFTWARE DESCRIPTION

For software realization in this research work, software named Keil is used.  $\mu$ Vision4 incorporated improvement atmosphere that summarized a development supervisor, built capability, device design, editor and a grateful

debugger.  $\mu$ Vision4 is used to write down and assemble the programs via the apparatus. It could move the assembly language as well as C code into the hex file.

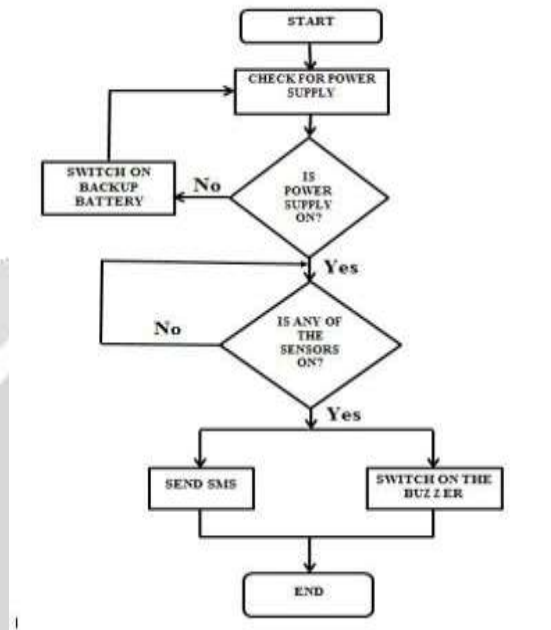

## 7. RESULT

The security system is can be enabled by Gas Sensor due to poisonous gases or by sound sensor when a person is unable to press the emergency button and shouts. Once the security system is enabled, the control room is alerted by a buzzer and a message by the GSM. Then the elevator automatically moves to the nearest floor and the door opens. Fig.9 shows the overall security system implemented in the elevator.

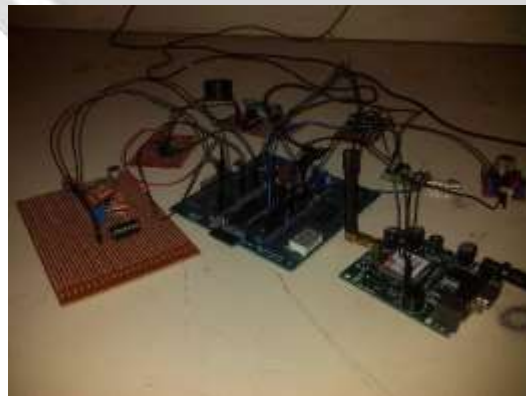

## 8. CONCLUSION

Our country has a large number of commercials and hospital buildings. In such buildings, the elevators play a major role for transportation between the floors. These elevators deserve a better security than the current systems. If proposed work is applied then elevators which are not secure would be secured.



## 9. FUTURE ENHANCEMENT

Pressure sensor plates can be employed at the floor of the elevator. This is used to sense if the passengers fall on the ground. When the passenger falls to the ground, the pressure plates will send an abnormal image in the system. This image will be detected automatically by the controller using image processing methods.

## 10. ACKNOWLEDGEMENT

I would like to thank my project guide Prof. R.V.PAEL for giving us guidance and help for the project. I am pleased to them for their support.

I am also thankful to Dr. D.P.KADAM HOD, SIEM NASHIK for her support and opinion.

## 11. REFERENCES

- [1] Al-Kodmany, K. *Eco-Towers: Sustainable Cities in the Sky*; WIT Press: Southampton, UK, 2015.
- [2] Nemeth, B. *Energy-Efficient Elevator Machines*; ThyssenKrupp Elevator: Frisco, TX, USA, 2011
- [3] Pederick, G. *How Vertical Transportation is Helping Transform Modern City*; CTBUH: Chicago, IL, USA, 2014; pp. 853–860.
- [4] Kwatra, S.; Essig, C. *The Promise and the Potential of Comprehensive Commercial Building Retrofit Programs*; ACEEE: Washington, DC, USA, 2014.
- [5] Gilleo, A.; Chittum, A.; Farley, K.; Neubauer, M.; Nowak, S.; Ribeiro, D.; Vaidyanathan, S. *The 2014 State Energy Efficiency Scorecard*; ACEEE: Washington, DC, USA, 2014.
- [6] Gifford, H. Elevator Energy Use. *Home Energy Magazine*, 12 February 2010.
- [7] Bass, P. *Energy Efficient Elevator Solutions for High-Rise Buildings*; CTBUH: Chicago, IL, USA, 2014.