

HYDROGEN POWERED PETROL VEHICLE (HHO ENGINE)

¹Prof.R.K.Pohane, ²Prof.S.M.Pimpalgaonkar, ³Prof. S.P.Daf
^{1,2,3}Asst.Prof. Priyadarshini Bhagwati College ,Nagpur,Maharashtra, India
¹raj.pohane@gmail.com, ²sandeepv17@gmail.com, ³shailu_daf@gmail.com

ABSTRACT- In this paper we have studied the basic properties of gas generated through electrolysis of water and then used this gas in the bike as a fuel with gasoline by mixing it with air. This results the increased mileage of bike 30 to 60% and reduce the polluting contents from the exhaust gases. The threat posed by climate change and the striving for securities of energy supply are issues high on the political agenda these days. Governments are putting strategic plan motion to decrease primary energy use, take carbon out of fuels and facilitate modal shifts. Taking a prominent place in these strategic plans is hydrogen as a future energy carrier. Energy stored in hydrogen would be available at any time and at any place on Earth, regardless of when or where the solar irradiance, the hydropower, or other renewable sources such as biomass, ocean energy or wind energy was converted.. Hydrogen gas combined with the standard air/fuel mixture increases the mileage. This form of alternative fuel is provided by a hydrogen generator mounted in the vehicle. Once set up is ready, the hydrogen gas (fuel) will be produced from water, an electrolyte compound, and electricity supplied from a battery provided. Here we are designing a mixed fuel two wheeler engine.ie in a conventional SI engine we are incorporating traces of hydrogen along with gasoline in order to minimum consumption of gasoline as well as to increase the power of vehicle. Here in addition, a hydrogen generating unit is made to produce hydrogen .It is actually an electrolysis unit having high grade stainless steel/graphite/semiconductors as electrodes in a closed container and mixture of distilled water & suitable ionic solution(KOH or NaOH) as electrolyte. Power for electrolysis is taken from an additional battery provided (12V).This battery can be recharged from a dynamo/alternator/motor provided on the vehicle.

Keyword- KOH, NaOH, SI engine, electrolysis of water, hydrogen cell.

INTRODUCTION-

Hydrogen powered bikes are those in which “**HYDROGEN CELL**” is used to produce a fraction of power for driving the bike. This results in decrease the fuel (petrol) thus increasing the mileage of the bikes. Hydrogen gas kit is latest innovation to increase mileage and power of vehicle.HHO kit. Combustion of fossil fuels has caused serious problems to the environment and the geopolitical climate of the world. The main Negative effects on the environment by Fossil fuel combustion are emissions of NO_x, CO, CO₂, and unburned hydrocarbons. The main negative effect of burning fossil fuel on the geopolitical oxygen and both are proportional to the total electrical charge conducted by the electrodes solution.

ELECTRICAL CONNECTION-

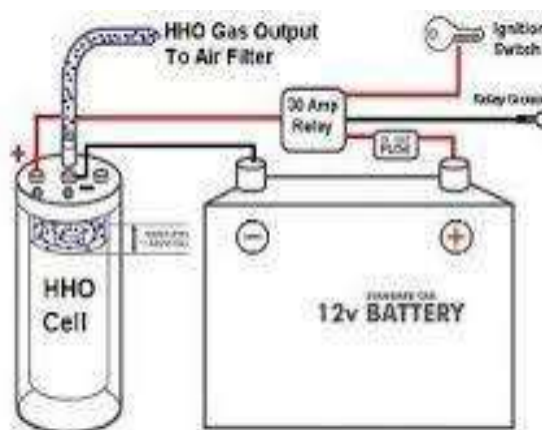

Climate is the lack in supply of these fuels and the effect pollution has on politics. Hydrogen is a clean fuel which on combustion produces water vapor as the only product. The use of hydrogen in IC engines not only helps increase the Monoxide, nitrous oxide etc. The use of using your engine using your engine hydrogen helps to reduce their use and hence prevent the depletion of these hence prevent the depletion of these Precious natural resources. Through a process of electrolysis water that is in a sealed container under your hood is converting to HO gas. This gas is then introduced to airflow in the intake manifold Vacuum. This gas is then mixed with the fuel providing better mileage. efficiency of it but also it helps to reduce pollution and reduce the poisonous gases like carbon

WORKING PRINCIPAL-

This works on the principal of electrolysis process. Electrolysis is the process that converts water to gas. The electrical supply for the process is used from your Vehicles battery and alternator. An electrical power source is connected to the two electrode materials which are placed in the water. Hydrogen will appear at the cathode (the negatively charged electrode, where electrons enter the water), and oxygen will appear at the anode material (the positively charged electrode).ie reduction at cathode and oxidation at anode occurs According to ideal faradaic efficiency. The amount of hydrogen generated is twice the number of moles of.

WORKING PROCESS-

The hydrogen generated at cathode is fed to the inlet manifold that is in air hose pipe of the carburetor, then this gas mix with the coming air from the air filter when the vacuum is created by the piston movement from TDC to BDC. As the hydrogen or HO gas mixed with air then it goes to engine cylinder with gasoline during suction stroke of the engine. At the end of compression stroke the spark is generated from the cold rated spark plug the combustion of gasoline and HO gas occurs.HHO itself contains 1/3 oxygen by volume and 2/3 hydrogen (which is only on gasoline. Therefore chances of blasting are reduced to zero.

COMBUSTIVE PROPERTIES OF HYDROGEN(brown gas)-

Low Ignition Energy-Hydrogen has very low ignition energy.

Ignition system- Avoid uncontrolled ignition, the spark plug gap can be decreased

High Auto ignition Temperature-The high auto ignition temperature of hydrogen allows larger compression ratios to be used in a hydrogen engine than in a hydrocarbon lower the ignition voltage; this is no problem for hydrogen engines as there will be almost no deposit formation. Spark plug gaps as small as 0.25mm has been used.

Carburetor setting-After having installed engine

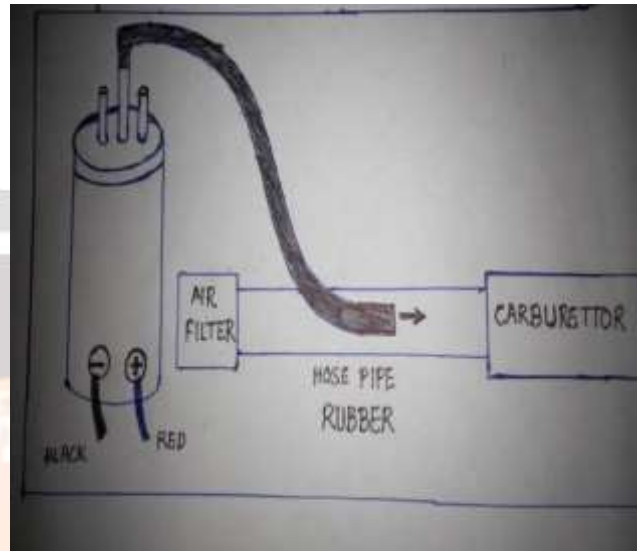

High Flame Speed- Hydrogen has high flame speed at stoichiometric ratios. Some basics the burn speed of hydrogen is 0.098 to 0.197 ft/min (3 to 6 cm/min) compared gasoline's 0.00656 to 0.0295 ft/min (0.2 to 0.9 cm/min). the Cell and electrical connections made properly, we set the carburetor correctly to achieve better mileage. 1) Adjust the Fuel Control Valve so that the fuel supply is decreased to minimal and engine runs in idle condition smoothly

High Diffusivity- Hydrogen has very high Diffusivity. Firstly, It facilitates the formation of a uniform mixture of fuel and Air. Secondly, if a hydrogen leak develops, The hydrogen disperses rapidly. Thus, unsafe conditions can either be avoided or Finer setting of fuel supply will result in Increased mileage of the vehicle. 2) Make sure to Fine Tune the Air Control Valve and Fuel Control Valve after running the vehicle for every 200 - 300 Kms until better mileage is achieved. As the Minimized. carbon deposits on the inside wall of the engine is removed, the vehicle performance.

Low Freezing point- Thus this creates no starting problem in the cold environment will increase gradually.

DESIGN MODIFICATION-

Spark plugs- Use cold rated spark plugs to avoid spark plug electrode temperatures exceeding the auto-ignition limit and causing backfire.

Use RTD (Resistance temperature detector)- RTD provide safety us because when the temperature of the engine of the bike exceed a particular limit then it cut off the gas supply consequently the bike will 3) Trick is to find Fine setting by "Allow Maximum Air" at maximum RPM and "Reduce Fuel Supply".

HARDWARE REQUIREMENT – A bike Hydrogen cell Connection pipes and cables Resistance temperature detector (RTD).

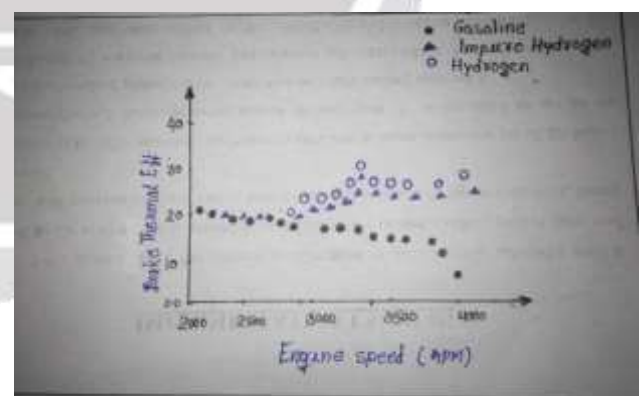
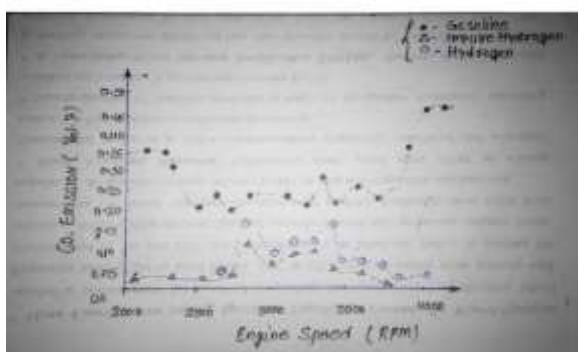
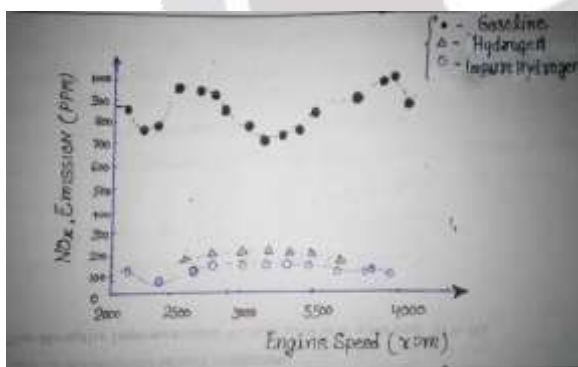

Cold rated spark plug Relay (30 amp) , fuse And others auxiliaries such as machine tools etc.

FEASIBILITY, NEED AND FUTURE SCOPE OF THE TOPIC- This project has reliability in itself being an automobile. This project is also very economical since the major factor of high level of fuel(petrol) prices in the country, would be reduced. All the components used in the project are real and available easily. Such type of bikes or Automobiles are needed more in india.

CHARACTERISTICS

the amount of money involved in the fuel consumption. Currently, in India, air pollution is widespread in urban areas where vehicles are the major contributors and in a few other areas with a high concentration of industries and thermal power plants. Hydrogen is a fuel with heat content nearly three times that of gasoline. From our work we experimentally found out that the efficiency of an IC engine can be rapidly increased by mixing hydrogen with gasoline. Hydrogen is the Key to a Clean Energy Future. Thus the hydrogen powered bike would be the major automobile used by the country since the fuel used have more advantages as compare to the conventional fuels

ADVANTAGES OF THE PROJECT-

- Eliminate harmful exhaust emission that pollute the environment and contribute to global warming. Your engine will add oxygen to the environment instead of polluting it. Increase in mileage of vehicle 45% to 60%.
- Increase in life of engine oil more than 2 to 3 times
- Increase in pick-up of vehicle
- Better smoother running engine
- Remove carbon deposits upto 50% and prevent future carbon buildup
- Reduce knocking of engine
- Reduce the operating temperature of the engine.
- Decreases oil consumption of engine
- Fuel Saving can be between 30% to 60 % depending up on viscosity of fuel, Driving style, Road conditions & other parameters.

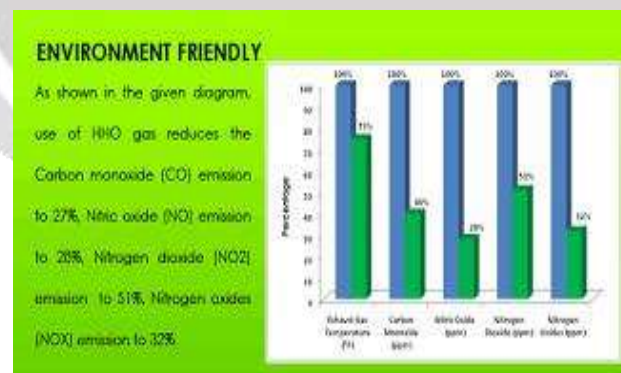

CONCLUSIONS

It is advantageous to use Brown's gas enriched air as a fuel in internal combustion engines. Significant impact on brake thermal efficiency And brake power is observed upon **the addition of Brown's gas enriched Air.** Fuel consumption and other emissions via: NO_x and smoke emissions are reduced to considerable amount. Hydrogen fuel enhancement from electrolysis (utilizing automotive alternators) has been promoted for use with gasoline-powered and diesel trucks, although electrolysis-based designs have repeatedly failed efficiency tests and contradict widely accepted laws of thermodynamics. This project will help our country to be energy

independence if it is used in a proper way. It will make India free from pollution that is going to be a major problem of the world.

REFERENCES-

1. NASA Technical Note, May 1977, " Emissions and Total Energy Consumption of a Multicylinder Piston Engine Running on Gasoline and a Hydrogen–Gasoline Mixture"
 - a. (Accessed 2008-08-08)
2. Hydrogen Internal Combustion Engine Vehicles Idaho National Laboratory.
3. G. Fontana, . Galloni, Jannelli and M. Minutillo (January 2002). "Performance and Fuel Consumption Estimation of a Hydrogen Enriched Gasoline Engine IJSER at Part-Load Operation". *SAE Technical Paper Series* (2002–01–2196): 4–5.
4. Mathur H.B., Das L.M. (1991). "Performance characteristics of a Hydrogen Fueled SI Engine using Timed Manifold Injection". *Int. J. Hydrogen Energy* (vol 16, pp.115–117, 1991).
5. Per Tunestal, Magnus Christensen, PatrikEinewall, Tobias Andersson, and Bengt Johansson (January 2002). "Hydrogen Addition for Improved Lean Burn Capability of Slow and Fast Natural Gas Combustion Chambers". *SAE Technical Paper Series* (2002–01–2686): 7–8.
6. Tsolakis A, Megacities A, Wyszynski ML, "Application of exhaust gas fuel reforming in compression ignition engines fueled by diesel and biodiesel fuel mixtures" *Energy & Fuels* 17 (6):1464–1473 NOV-DEC 2003.
7. Yougen Kong, Sam Crane, Palak Patel and Bill Taylor (January 2004). "NO_x Trap
8. Regeneration with an On-Board Hydrogen Generation Device". *SAE Technical Paper Series* (2004–01–0582): 6–7.
9. Thorsten Allgeier, Martin Klenk and TiloLandenfeld (January 2004). "Advanced Emissions and Fuel Economy Control Using Combined Injection of Gasoline and Hydrogen in SI-Engines". *SAE Technical Paper Series* (2004–01–1270): 11–12.
10. See list of devices tested under EPA Gas Saving and Emission Reduction Devices Evaluation.
11. US Environmental Protection Agency, "Devices and Additives to Improve Fuel Economy and Reduce Pollution - Do They Really Work?"