

Hybrid Power System with Different Controllers and Tracking Methods -A Review

Sachin Pal (MTech Scholer), Bhopal Institute of Technology, Bhopal
Namrata Sant(Asst.Prof.), Bhopal Institute of Technology, Bhopal

Abstract

For fulfilling the global energy demand hybrid energy system is the better option. Hybrid energy system is the integration of wind, solar, hydro etc different renewable energy sources to that of existing transmission distribution system. This paper is a review on stability of hybrid power system. In this paper analysis of stability problem and different controllers which affects the output power of hybrid power system are discussed. The main problems of hybrid system is involved with stability and power quality. For these problems improvement many types of facts devices and other methods are used. Nowadays hybrid power system are increasingly used. The majority of the work is based upon the use of different controllers and controlling techniques which is used for maximum power generation of hybrid system with good power quality.

Keywords: MPPT, Facts devices, multilevel-inverter, fuzzy logic, neural net

I. INTRODUCTION

Hybrid energy system is the combination of conventional and renewable energy sources like wind, solar, hydro etc. These provide a clean and eco-friendly energy. These hybrid systems can be standalone or can be grid connected. The grid connected hybrid system are more reliable to deliver continuous power to the grid because if there is any shortage of power or fault in the renewable energy sources then the loads are directly connected to the grid. Since the wind and sunlight are not constant at all the time in a day these causes stability problem of hybrid system. For improving the stability problem in the system various types of FACTS devices are used. The UPFC, IPC, Fuzzy logic, SVC, STATCOM etc are used for maintaining the stability of the system.

And for maximum power generation and continuous operation, maximum power point tracking techniques are used in which extraction of maximum wind and sunlight is done for generating maximum power of hybrid system.

II. CONTROLLER FOR SOLAR AND WIND HYBRID POWER SYSTEM

The major issues involved in wind and solar hybrid power system are power quality and voltage stability. As both the sources are renewable, the output of each source depends upon the nature. The wind speed is not constant at all the time and also the sunlight varies throughout the day. In rainy season the solar power system will not operate. Due to this, voltage will not be constant and power quality is affected. For this different controllers are used to maintain the stability and to improve the power quality. The UPFC D-STATCOM, IPFC, SVC, SSSC, Fuzzy logic controllers are used for power stability and for improving power quality. The Voltage stability of power system is reduced due to voltage swell, sag and the harmonics generated in the system. The FACTS devices are connected at the output terminal of the inverter before supplying to the load. These FACTS devices helps in reducing the harmonics present in current waveform which improves the power quality. The STATCOM used is a Static Synchronous Compensator used as a shunt compensating device for reducing reactive power compensation, improving the steady state of system and also transient stability. It is used both for the reactive and active power compensation.

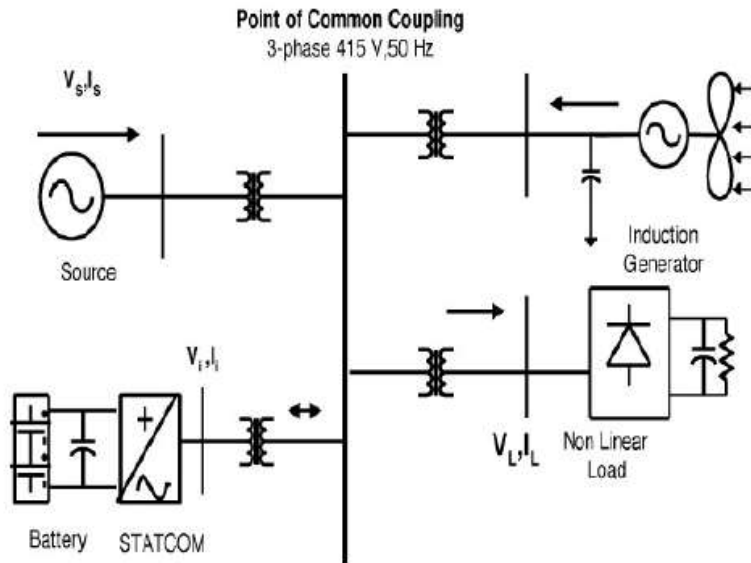

Figure 1: Grid connected FACTS system for power quality improvement

Fuzzy logic controller for Hybrid system

Hybrid system consisting of PV and wind are the main energy sources. The output of PV is dc but output of wind is ac, this ac is converted to dc by the help of inverter. The dc to dc converters are also connected in this system. And at the grid side inverter is connected for changing dc to ac. The power is controlled in the system by the help of fuzzy logic controller. The Fuzzy logic controller reliable and stable. They have low power dissipation and optimized cost. They are based on fuzzy set theory and it is a non-linear control method. This is used for providing constant knowledge. The power is managed in the system by fuzzy logic controller. There are 3 steps in Fuzzy logic controller, these are

1. Fuzzification
2. Fuzzy inference system
3. Defuzzification

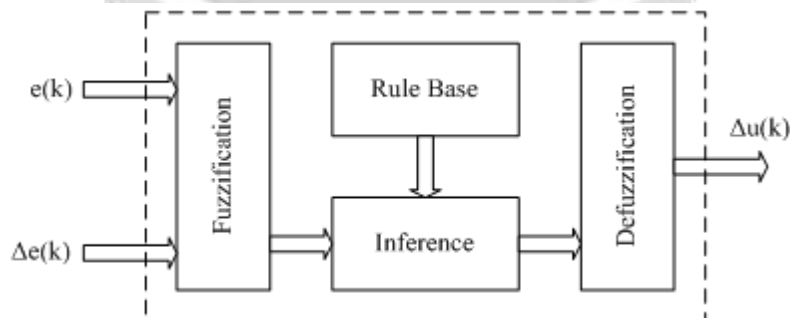

Figure 2: Structure of Fuzzy logic controller

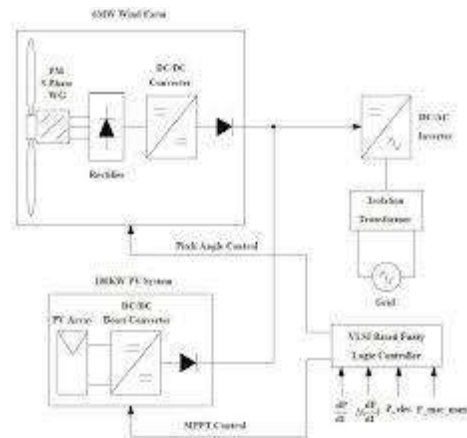

Figure 3: Block diagram of Hybrid system with Fuzzy logic controller

Fuzzification includes designing of input and output membership function. The fuzzy data are obtained from the classical data. In Fuzzy inference system, the relationship between input and output membership functions is designed. The control rules are combined with the membership functions. In Defuzzification, the output of the fuzzy logic controller is obtained. The lookup table is used for the value and by the help of different methods the value is calculated.

III.IMPROVEMENT OF POWER QUALITY IN HYBRID SYSTEM WITH MULTILEVEL INVERTER

The power quality of multilevel inverter depends on the number of levels. The main advantage of multilevel inverter is that the output voltages can be generated with low harmonics. These inverters are used for high power applications. The harmonics causes the increase in current which results in increase of current in neutral. In hybrid system, the sources are first connected to dc-dc converter and then to multilevel inverters. Different topologies of converters are used, like Two-Level Voltage Source Converters; Three-Level Diode clamped Voltage Source Converters, Four- Level Flying Capacitor Voltage Source Converters and Series Connected H-Bridge Voltage Source Converters. The most commonly used multilevel converter topology is the diode clamped inverter, in this the diode is used as the clamping device to clamp the dc bus voltage so as to achieve steps in the output voltage level three, seven inverters can be considered. The low order harmonics amplitude will decrease when the number of level increases. Since high frequency harmonics are easy to filter so the inverter used is usually followed by a low pass filter. Thus the performance of multilevel inverters can be improved by reducing lower order harmonics. PI controller can also be used for regulating the DC bus voltage at a constant value.

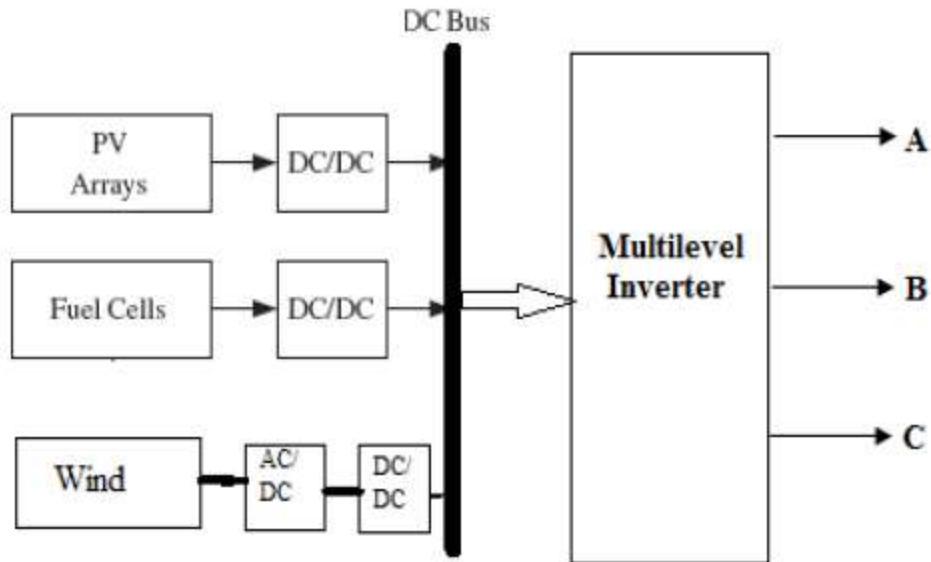

Figure 4 : Block Diagram of Hybrid System with Multilevel Inverter

IV. NEURAL NETWORK CONTROL FOR HYBRID SYSTEM

Artificial neural networks are useful in improving efficiency of renewable energy system for solar energy. The neural networks are used in time series forecasting for solar energy it is used for prediction of solar irradiance and also used for sizing application. Artificial neural network (ANN) system are also used for maximum power point tracking (MPPT) and applications for PV power system. Artificial neural network is used for wind energy conversion system which is mostly dependent on the controlling of pitch angle of wind turbine. These are used for the propeller of wind turbine for gaining maximum performance from wind energy. ANN applications of wind turbine are used for the prediction of wind speed and direction. The architecture of an ENN includes the input layer, the hidden layer, the context layer, and output layer .

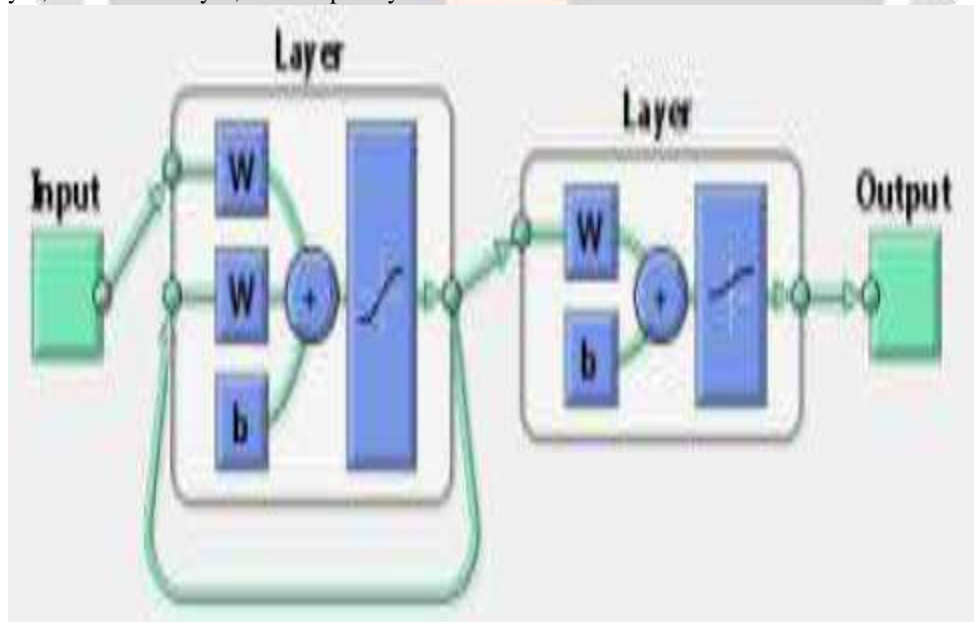

Figure 5 : Simple Elman Neural Network

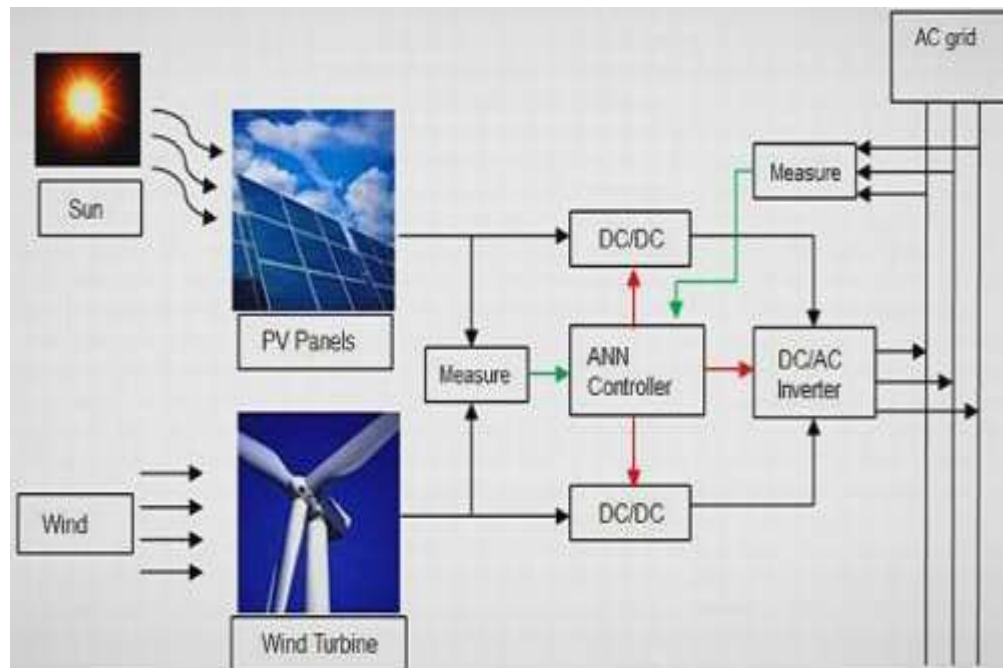

Figure 6 : Hybrid power system with neural network controller

V. MAXIMUM POWER POINT TRACKING (MPPT) IN WIND AND SOLAR HYBRID POWER SYSTEM

Renewable energy sources are increasingly used due to limited use of conventional energy sources. The hybrid energy system consist of main sources but mainly used sources are wind and solar. These energy sources are of variable nature. The wind speed and sun light are not constant throughout the day, it changes all the time. So there is a problem in extraction of maximum power from these sources. For extracting maximum power from wind and solar, we use maximum power tracking system. Due to this the electrical power output of hybrid system is increased. The MPPT used in solar energy gives the control signal to the dc to dc converter and these controlled outputs is given to the grid or to the load. Similarly for wind energy also maximum power point tracking is used for getting maximum power by controlling wind speed. The MPPT maximizes the efficiency of the system. There are many algorithms which help in tracing the maximum power point of the PV module. They are following:

1. P&O algorithm
2. IC algorithm
3. Parasitic capacitance
4. Voltage based peak power tracking
5. Current Based peak power tracking

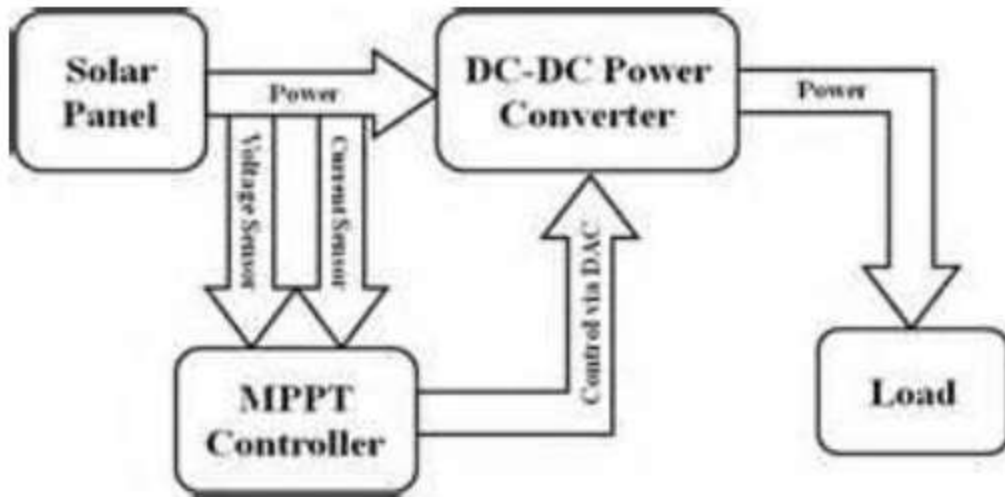

Figure 8: Tip speed ratio control of WECS

VI USE OF HYBRID FILTERS

The power quality can be improved by the use of hybrid filters. The renewable energy sources are connected to the grid by dc-dc converter and hybrid filter. The gate pulses for hybrid system are controlled by the help of hysteresis controller. By using synchronous reference frame the reference current for hysteresis controller is obtained. The hybrid controllers are not only used for controlling harmonics and also for compensating positive and negative sequence reactive power. Hybrid Filters are of different types, it can be of shunt active power filter and passive filter acts as hybrid filter. It ensures the compensation of source current harmonics. Series and Parallel resonance are eliminated by this hybrid arrangement. The active and passive filters are connected in Series and the arrangements are connected parallel to the grid. Because of these filters the non linear loads that produce the harmonic current are reduced.

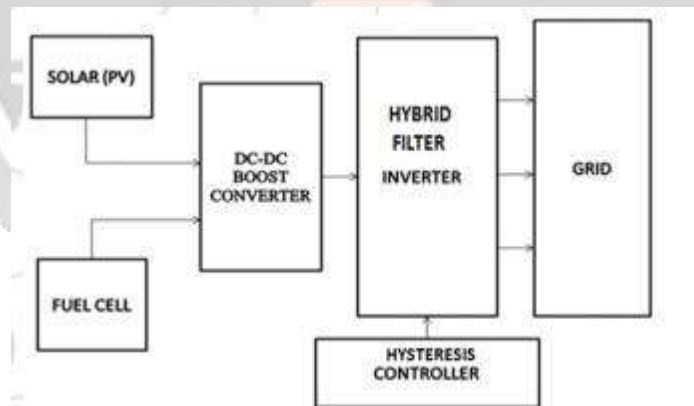

Figure 9: Block diagram of hybrid system

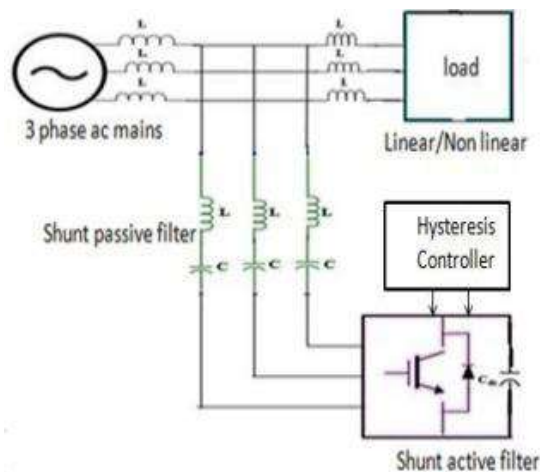

Figure 10: Hybrid filter connected to grid

VII. ECONOMIC EVALUATION OF THE HYBRID SYSTEM

The hybrid system cost maintains the capital cost, maintenance cost and replacement cost. By using renewable energy sources, mainly wind and solar, lower adverse effects on environment is done. The evaluation is done of the wind and solar hybrid plant connected to entire network. All analysis done by HOMER software. The economic analysis is done by the help of life cycle cost method. In this method, it includes all cost that are involved over the life. This method is used for the hybrid power system. Thus economic evaluation is done of the hybrid power system.

VIII. CONCLUSIONS

In this paper review of the power quality improvement of hybrid power system is discussed. By using various types of FACTS devices. The Fuzzy logic controller is used for controlling the power in system and by making system stable. In this paper also discussed about the maximum power point tracking method of maximum wind and sunlight for hybrid power system. The harmonics in hybrid power system is reduced and power quality is improved by the use of multilevel inverters. The artificial neural network is used for improving the efficiency of the system. Another method of improving the power quality in hybrid power system is by the use of hybrid filters. The economic evaluation of hybrid power system can be done by the use of life cycle cost method.

REFERENCES

- [1] K.R. Padiyar, Nagesh Prabhu, "Analysis of SSR by three-level three inverter VSC –based interline power flow controller", IEEE transaction on power delivery, vol 22, no.3.
- [2] Natsheh, Albarbar "Hybrid Power Systems Energy Controller Based on Neural Network and Fuzzy Logic" *Smart Grid and Renewable Energy*, 2013, 4, 187-197
- [3] Swati Negil and Lini Mathew "Hybrid Renewable Energy System: A Review" *International Journal of Electronic and Electrical Engineering*. ISSN 0974-2174, Volume 7, Number 5 (2014)
- [4] T.Shanthi, Vanmukhil "Fuzzy Logic based MPPT Control of Hybrid Power Generation System" *International Journal of Computer Applications (0975 – 8887) Volume 86 – No 1, January 2014*
- [5] In-Su Bae, Jin-O Kim, "Reliability evaluation of distributed generation based upon the operation mode", IEEE transaction on power system, vol.22 no.2.(2007)
- [6] Gyugi, K.Sen, Schauder (1999), "the interline power flow controller concept: a new approach to power flow management in transmission system", IEEE transaction on power delivery
- [7] Dali, M., Belhadj, J., and Roboam, X., "Hybrid solar-Wind System with Battery Storage Operating in Grid-Connected and Standalone Mode: Control and Energy Management – Experimental Investigation," *Energy*, Vol. 35, No. 6, pp. 2587-2595, 2010.
- [8] Roopesh, Ashish Chubby (2014) "voltage stability improvement using svc and fuzzy logic controller in multimachine", *international journal of electrical and electronics research*. Vol. 2, Issue 2
- [9] Karunakaran Karthikeyan (2011), "Reactive power management for wind electric generator", *International Journal of Scientific & Engineering Research* Volume 2, Issue 5.

- [10] Aghera, Savasani “Solar-Wind Hybrid System Generation and Control Using Power Electronics Devices” 2014 IJEDR | Volume 2, Issue 3 | ISSN: 2321-9939
- [11] Whei-Min Lin, *Member, IEEE*, Chih-Ming Hong, and Chiung-Hsing Chen “Neural-Network-Based MPPT Control of a Stand-Alone Hybrid Power Generation System” IEEE TRANSACTIONS ON POWER ELECTRONICS, VOL. 26, NO. 12, DECEMBER 2011
- [12] Wang, Freitas (2008), “impact of positive feedback anti islanding methods on small signal stability of inverter based distributed generation”, IEEE transaction on energy conversion, vol.no. 23, no.3.
- [13] Dr.K.S.Srikanth, T.Krishna Mohan” A Novel Grid-Connected PVFC Hybrid System for Power-Management” *International Journal of Research in Advent Technology, Vol.2, No.4, April 2014*
- [14] Giraud and Salameh, “Steady-State Performance of a Grid- Connected Rooftop Hybrid Wind–Photovoltaic Power System” IEEE TRANSACTIONS ON ENERGY CONVERSION, VOL. 16, NO. 1, MARCH 2001 1 with Battery Storage
- [15] Djamel and Abdallah, “Power Quality Control Strategy for Grid- Connected Renewable Energy Sources using PV Array, Wind Turbine and Battery,” Proc. of 2013 Fourth International Conference on Power Engineering, Energy and Electrical Drives (POWERENG), pp. 1671-1675, 2013.
- [16] Meshram, S., Agnihotri, G., and Gupta, S., “Performance Analysis of Grid Integrated Hydro and Solar Based Hybrid Systems,” *Advances in Power Electronics*, Vol. 2013, pp. 1-7, 2013.
- [17] Ibrahim et al, “Performance investigation of photovoltaic grid Connection for shunt active power filter with different pwm generation”, *Journal of Theoretical and applied Information Technology*, 2, 2013
- [18] Srividya.P.K and Vivek, “Power Quality Improvement techniques in Hybrid systems”, *International Journal of Advanced Technology and Engineering Research*, 3(5), Sept 2013.

