

MEDICINE REMINDER SYSTEM USING ARDUINO

Pallavi Somnath Gaikwad¹, Tanvi Santosh Bharade², Vikas Solanke³

¹ Student, Department of Computer Engineering, M. M. Polytechnic, Pune, Maharashtra, India.

² Student, Department of Computer Engineering, M. M. Polytechnic, Pune, Maharashtra, India.

³ Lecturer, Department of Computer Engineering, M. M. Polytechnic, Pune, Maharashtra, India.

ABSTRACT

We always want to stay them healthy and fit. But what will happen if they get ill and forget to take medicine on time. We would be worried, At hospitals, there are many patients and it is difficult to remind every patient to take medicine on time. The traditional ways require human efforts to remind them to take medicines on time. The digital era doesn't follow that and we can use machines to do that. The application of Smart Medicine Reminder System is very wide and can be used by patients at home, doctors at hospitals, and at many other places. When it comes to reminding, there can be many ways to remind it

Keyword : - Medicine alarm System, Notification sound, Sensing capability, Arduino, Patient Health, Medicine

1. INTRODUCTION

The In recent times, the rate of consumption of medicines has highly increased due to the wide spreading of different diseases and illnesses across the globe. While some diseases are temporary, many diseases have a toll on human health for a lifetime. In the pursuit of maintaining a healthy lifestyle, we often find ourselves to be sick. This could be threatening if not properly treated. A visit to the doctor and consumption of the medical prescription becomes a necessity. Nevertheless failing to consume the medicine regularly could cause a lot of problems. Keeping in mind this problem, the idea of creating a smart device that alerts the patient to take medicines right on time, so that they would recover soon and stay healthy without any issues in the body.

2. SYSTEM AND COMPONENTS

2.1 Arduino Nano

The Arduino Nano is Arduino's classic breadboard friendly designed board with the smallest dimensions. The Arduino Nano comes with pin headers that allow for an easy attachment onto a breadboard and features a Mini-USB connector.

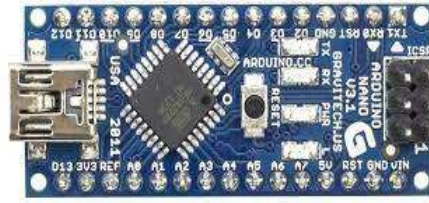

Fig -1: Arduino Nano

2.2 DS3231 RTC Module -1

RTC means Real Time Clock. RTC modules are simply TIME and DATE remembering systems which have battery setup which in the absence of external power keeps the module running. This keeps the TIME and DATE up to date. So we can have accurate TIME and DATE from RTC module whenever we want.

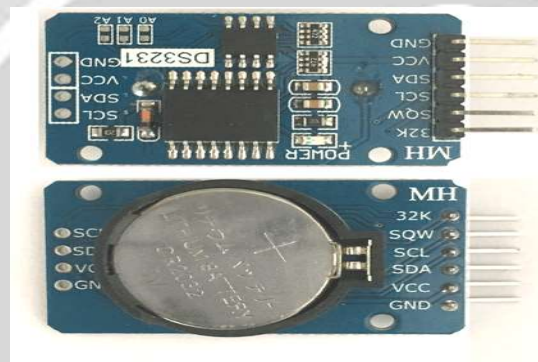

Fig -2: DS3231 RTC Module

2.3 LCD

In LCD 16x2, the term LCD stands for Liquid Crystal Display that uses a plane panel display technology, used in screens of computer monitors & TVs, smartphones, tablets, mobile devices, etc. Both the displays like LCD & CRTs look the same but their operation is different. Instead of electrons diffraction at a glass display, a liquid crystal display has a backlight that provides light to each pixel that is arranged in a rectangular network.



Fig -3: LCD

2.4 Push-Button

The "push-button" has been utilized in calculators, push-button telephones, kitchen appliances, and various other mechanical and electronic devices, home and commercial.

In industrial and commercial applications, push buttons can be connected together by a mechanical linkage so that the act of pushing one button causes the other button to be released. In this way, a stop button can "force" a start button to be released. This method of linkage is used in simple manual operations in which the machine or process has no electrical circuits for control.



Fig - 4: Push button

2.5 Potentiometer

Potentiometers also known as POT, are nothing but variable resistors. They can provide a variable resistance by simply varying the knob on top of its head. It can be classified based on two main parameters. One is their Resistance (R-ohms) itself and the other is its Power (P-Watts) rating.



Fig – 5 : Potentiometer

2.6 Resistor

A resistor is a passive two-terminal electrical component that implements electrical resistance as a circuit element. In electronic circuits, resistors are used to reduce current flow, adjust signal levels, to divide voltages, bias active elements, and terminate transmission lines, among other uses. High-power resistors that can dissipate many watts of electrical power as heat may be used as part of motor controls, in power distribution systems, or as test loads for generators. Fixed resistors have resistances that only change slightly with temperature, time or operating voltage. Variable resistors can be used to adjust circuit elements (such as a volume control or a lamp dimmer), or as sensing devices for heat, light, humidity, force, or chemical activity.

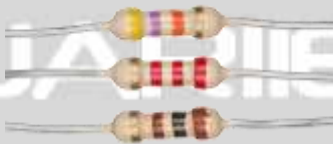

Fig – 6 :Resistor

3.METHODOLOGY

Method We can combine ways depending upon the need. To keep things simple here we made a Medicine Reminder using Arduino which reminds us to take medicines 1 or 2 or 3 times a day. The time slot can be selected using push buttons. Also, it shows the current Date and Time.

II. BLOCK DIAGRAM

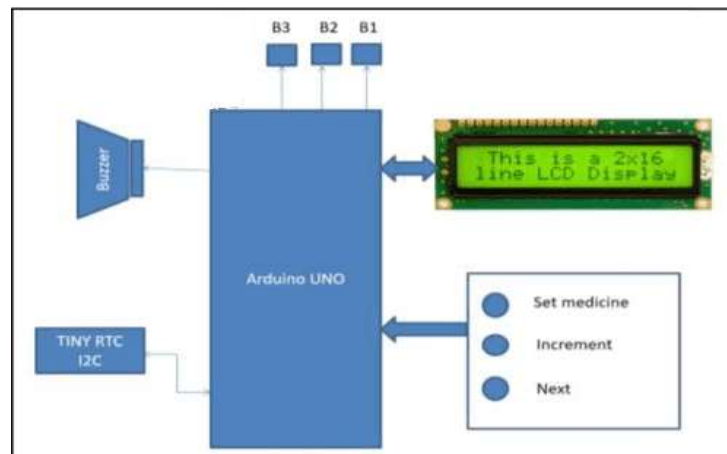

Fig – 7: Block Diagram

3.1 Explanation of Project :

1) Arduino NANO: We are using Arduino NANO because it use 8 bit microcontroller ATmega328P and it has 32KB flash memory. These features are beneficial in our project and that's why we used Arduino NANO. Arduino NANO board is connected with all other modules also it controls all other modules & made the interfacing easier. It also has internal EEPROM which stores real time data in it. Our project is based on embedded system we are using Arduino Uno for interfacing all things In that Arduino is an open-source which is easy-to-use hardware and connected software. So Arduino is path between hardware and software. Arduino boards read inputs from a press a button- and turn it into an output, turning on an LED and buzzer, you can tell your board what to do by sending a set of instructions to the microcontroller of Arduino. To do so you use the Arduino programming language , and the Arduino Software (IDE), based on Processing. The programming platform is Arduino IDE and programming language is standard C. we made program for all different module that we are using in our project. Like RTC module, LCD module 16*2 so firstly we have to add library in Arduino IDE software and after that we made programming.

2)LCD interfacing: We used 16*2 LCD module in our project which is connected to Arduino NANO through a LCD interface IC or directly to its address and data bus and few control pins. LCD shows the current time and date which RTC sends the data to LCD module.

3)RTC module: We used Tiny RTC I2C module which uses I2C protocol and it is useful in our project. RTC module has internal CMOS cell so it does not needs external power supply to update time and date.

4)Buzzer: Buzzer will ring at proper time when pills have to be taken.

5)LED: We have 7 boxes having an LED in each box which blinks to show us the specific box from which the pills needs to be taken at given time.

6)Pushbuttons: We used 3 push buttons from which first one is used for setting medicine, second one is used for increment and third one is used for next. First button takes us to the menu of setting medicine, second button is used to increment the number of hour and minute which we needs to set and third button takes us forward from hour to minute and from minute to the next time.

4.WORK FLOW

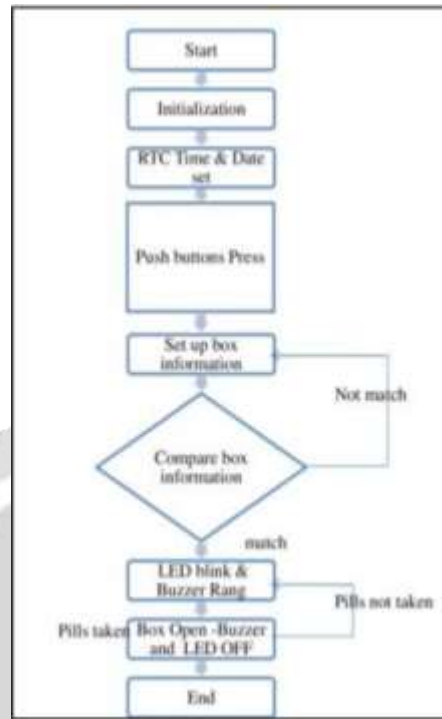

5.RESULT



6. CONCLUSIONS

The goal of our project is to provide healthy and tension free life to those users who are taking regularly pills and to provide this product at affordable cost also. Our project's objective is to help elderly people. We conclude the results that our project is useful for those elderly people who take pills regularly and whose course of prescription is very long and difficult to remember. This device will notify them at the right time, the right medicine to be taken. This in turn helps them to stay fit and healthy without any issues.

7. REFERENCES

- [1] <https://www.maxiaids.com/t/pill-boxes>
- [2] https://www.researchgate.net/publication/329299641_Smart_drugsImproving_Healthcare_using_Smart_Pill_Box_for_Medicine_Reminder_and_Monitoring_System
- [3] www.google.com
- [4] <https://www.sciencedirect.com/science/article/pii/S2314728818300230>
- [5] www.youtube.com
- [6] <https://create.arduino.cc/projecthub/thestevenbell/arduino-alarm-system-db084a>

