

# Monthly Electricity Billing via SMS using GSM

**Pallavi R. Borade, Shraddha S. Birari, Prajakta B. Morade**

*B.E (E&TC) Student, S.V.I.T, Chincholi, Nasik, Maharashtra, India.*

## ABSTRACT

*The previous method of meter reading was manual where person have to go physically and should take the photo of meter reading then he have to add the reading in the cell phone according to consumer no then the bill is generated. Due to this process the extra time required to this so we have come with no idea. The main objective of the project is to develop a GSM based energy meter reading system and load control through GSM. Electricity department sends employees to take meter reading every month, which is an expensive and time consuming job. The proposed project provides a convenient and efficient method to avoid this problem. The electricity department and the user can get the readings of the energy meter of consumers via SMS. The loads can also be controlled by the user of this system via GSM using this project. A Controller input is effectively in GSM Based to a digital energy meter that takes the reading from the energy meter and displays the same on an cell phone display. The reading of the energy meter is also sent to the control room by GSM. This GSM can also receive commands from the Software to control the owners electrical loads. On receiving command it can switch ON/OFF the loads.*

**Keywords:** -. *Monthly electricity billing by sms system(MEBS); GSM; PIC; Short messaging system(SMS);C.*

## 1. INTRODUCTION

Electrical power has become indispensable to human survival and progress. Apart from efforts to meet growing demand, automation in the energy distribution is also necessary to enhance peoples life standard. Traditional meter reading by human operator is inefficient to meet the future residential development needs. So there is increased demand for Automatic Meter Reading (AMR) systems which collects meter readings electronically, and its application is expanding over industrial, commercial and utility environment.

Electronic utility meters are an important step towards automating the utility metering process. Automated utility meters have many new features that help to reduce the cost of utilities to customers and the cost of delivering utilities to the utility provider. The onset of rural electrification provides opportunities for new and more efficient metering technologies to be implemented. Traditional electro-mechanical meters, still widely used today, are prone to drift over temperature and time as a result of the analogue and mechanical nature of the components in these meters. Collection of meter readings is also inefficient, because a meter reader has to physically be on site to take the readings. This method of collecting of meter readings becomes more problematic and costly when readings have to be collected from vast, and often scattered rural areas. Meter readers are reluctant to make the effort to travel to such areas and will often submit inaccurate estimations of the amount of electricity consumed. For households at the top of high buildings and luxury housing plots, traditional meter reading is highly inefficient.

There exists chance for missing bills, absence of consumer etc. Even though these conventional meters were replaced with more efficient electronic energy meters these problems still persists. So a system which will provide the bill in users mobile will be more suitable in the current scenario. Here a new method of postpaid electronic energy metering is introduced in this paper which will automatically sense the used energy, records these reading continuously, then sends it to the billing point through the existing GSM network. Finally after processing the collected data bill is generated using a web based system software and is send back to the customer as SMS (Short

Messaging System). As it is web oriented once the data is updated, the registered users and authority can monitor and analyse the generated bill of any month by sitting anywhere in the world.

Also, if 3 phase supply is connected for residence or office or college anywhere we need. Then sometimes there may be any phase will be absent because of some critical situations. So, in this condition if any phase is absent then it will be detected that which phase is not present among R Y B phases. User will know by SMS about absence of phase.

## **2. LITERATURE SURVEY**

For this work existing meter reading techniques in India are analyzed and conducted an extensive study on different energy measuring instruments available now. In existing system either an electronic energy meter or an electro-mechanical meter is fixed in the premise for measuring the usage. The meters currently in use are only capable of recording kWh units. The kWh units used then still have to be recorded by meter readers monthly, on foot. The recorded data need to be processed by a meter reading company. For processing the meter reading, company needs to firstly link each recorded power usage datum to an account holder and then determine the amount owed by means of the specific tariff in use. In this project the front end is User friendly and any employee with minimum knowledge of computers can work on this software. Employees can read the meter by sitting in their office.

## **3. EXISTING SYSTEM**

In existing system method of meter reading was manual where person have to go physically and should take the photo of meter reading then he have to add the reading in the cell phone according to consumer no then the bill is generated. Due to this process the extra time required to this so we have come with no idea

## **4. PROPOSED SYSTEM**

In our proposed system, . The main objective of the project is to develop a GSM based energy meter reading system and load control through GSM. Electricity department sends employees to take meter reading every month, which is an expensive and time consuming job. The proposed project provides a convenient and efficient method to avoid this problem. The electricity department and the user can get the readings of the energy meter of consumers via SMS. The loads can also be controlled by the user of this system via GSM using this project.

## **5. SYSTEM ARCHITECTURE**

When system will be in ON condition, LCD will show the current reading in meter. After some time the reading will changing. Microcontroller sends SMS of reading in meter to user by using GSM system. Also if any phase will be absent, then user will know about absent phase by SMS.

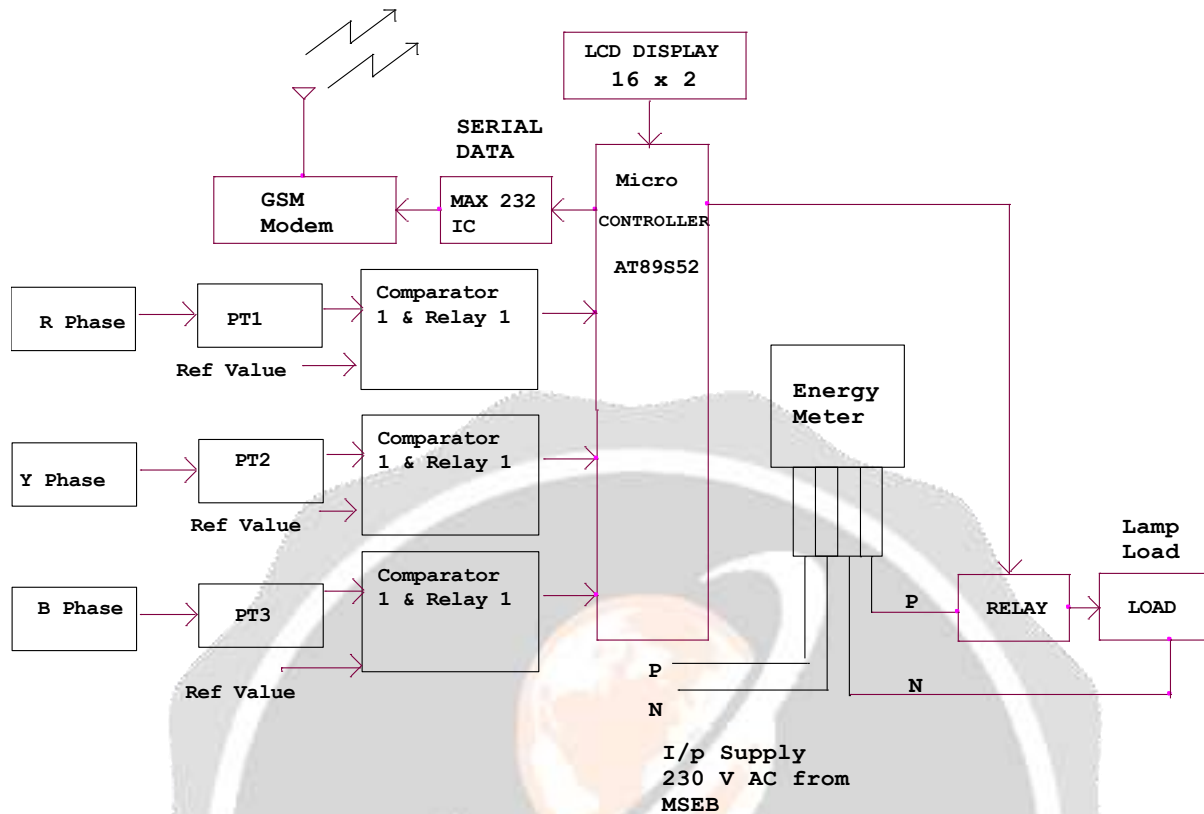

Fig -1: Block Diagram

a. **Power Supply:**

For our system we require power supply, for microcontroller and its peripheral devices. It is used to supply the power to Max232 and microcontroller, LCD, etc

b. **Microcontroller:**

In this project we have used a microcontroller 89S52. Which is the heart of the project. This controls all the functions of project. Which will Continuously Monitor the Meter reading.

c. **Comparator:**

Comparators are designed to operate in open loop configuration without any negative feedback. In most cases, they are not internally compensated. The speed (propagation delay) and slew rate (rise and fall time) are maximized. The overall gain is also usually higher. The use of an op amp as a comparator leads to an un optimized situation, where current consumption versus speed ratio is low. The opposite is even worse. Normally, a comparator cannot be used instead of an op amp. Most probably, the comparator shows instability under negative feedback. Generally speaking, comparators and operational amplifiers cannot substitute each other except for low performance designs.

**d. 16\*2 LCD:**

We are using LCD display to display the meter reading. It is interfaced with microcontroller. Alphanumeric displays are used in a wide range of applications, including palmtop computers, word processors, photocopiers, point of sale terminals, medical instruments, cellular phones, etc. The 16 x 2 intelligent alphanumeric dot matrix display is capable of displaying 224 different characters and symbols. A full list of the characters and symbols is printed on pages 7/8 (note these symbols can vary between brand of LCD used). This booklet provides all the technical specifications for connecting the unit, which requires a single power supply (+5V). Available as an optional extra is the Serial LCD Firmware, which allows serial control of the display. This option provides much easier connection and use of the LCD module. The firmware enables microcontrollers (and microcontroller based systems such as the PICAXE) to visually output user instructions or readings onto an LCD module. All LCD commands are transmitted serially via a single microcontroller pin. The firmware can also be connected to the serial port of a computer

**e. GSM modem:**

GSM modem using for communication with MSEB and user through SMS

**f. Relay:**

Relays are electromechanical switches. They have very high current rating and both AC and DC motors can be controlled through them because motor will be completely isolated from the remaining circuit. Relays consist of an electromagnet, armature, spring and electrical contacts. The spring holds the armature at one electrical contact and as soon as a voltage is applied across the electromagnet, it coils the armature, changes its contact and moves to another electrical contact.

**4. SYSTEM REQUIREMENT SPECIFICATION****4.1 SOFTWARE REQUIREMENTS**

- Protel (For making PCB)
- Keil Software ( For writing Code )

**4.2 HARDWARE REQUIREMENTS**

- Energy Meter.
- Microcontroller 89c52
- Transformers.
- GSM Modem
- LCD Display.
- Load.
- MAX232.

**5. TECHNICAL SPECIFICATIONS****5.1 ADVANTAGES**

- Reduce Man power
- Reduce Time
- Reduce Paper
- Due to easy phase cut detection, further problems can be avoided.
- If Customer not paying bill MSEB officer can Cut power Supply Remotely
- After Customer paying bill MSEB officer can ON power Supply Remotely

## 5.2APPLICATIONS

- Dynamic Update of Meter reading on mobile.
- Reduce Man power & paper work for Sending Energy Bill Manually.
- Complete Automation of Sending Meter Reading.

## 6. CONCLUSION

The microcontroller based GSM METER READING WITH AUTOMATIC LOAD ON/OFF and 3 PHASE DETECTION we designed is working properly. We can easily know about the absent phase among R Y B. By doing the project, we got a lot of experience with the electronic components and more over we learn the PCB designing tips.

## 7. ACKNOWLEDGEMENT

We take this opportunity to express our hearty thanks to all those who helped us in the completion of the paper. We express our deep sense of gratitude to our guide Prof. P. A. Chaudhari Asst. Prof., E&TC Engineering Department, Sir Visvesvaraya Institute of Technology, Chincholi for her guidance and continuous motivation. We gratefully acknowledge the help provided by her on many occasions, for improvement of this project report with great interest. We would be failing in our duties, if we do not express our deep sense of gratitude to Prof. R. R. Bhambhare, Head, Electronics And Telecommunication Engineering Department for permitting us to avail the facility and constant encouragement. Lastly we would like to thank all the staff members, colleagues, and all our friends for their help and support from time to time.

## 8. REFERENCES

- i. Masood Khan, Pratik Bhosle, Sandesh Dalvi "Wireless Electronic Notice Board Using GSM Technology," International Journal For Research in Applied Science & Engineering Technology, Volume-3, Issue-V, May-2015.
- ii. H.G. Rodney, Tan IEEE, C.H. Lee and V.H. Mok 2007. Automatic Power Meter Reading system using GSM Network. The 8th International power Engineering Conference, PP:465-469
- iii. Power Meter Store. Measure Power Meter at the plug. Web. 30 November 2010
- iv. T El-Djazairy, B J Beggs and I F Stewart, Investigation of the use of the Global System for Mobile Communications (GSM) network for metering and load management telemetry, Electricity Distribution. Part 1: Contributions. CIRED. 14th International Conference and Exhibition on (IEE Conf. Publ. No. 438)
- v. Li Kaicheng, Liu Jianfeng, Yue, Congyuan, Zhang Ming. Remote power management and meter-reading system based on ARM microprocessor, Precision Electromagnetic Measurements Digest, 2008. CPEM 2008. Conference on Digital Object Identifier