

Numerical Simulation of Fins Mounted On Inner Tube of Single Tube Fire Water Heater

Mr. Dandge A.G. Mr. Pingale Rohit

Abstract

The rate of heat transfer to water around a pipe can be greatly enhanced by the use of extended fins. The main objective in improving the performance of thermal system is to enhance heat transfer. To increase thermal performance of water heating boiler, it is necessary & effective to employ extended surface, referred to as fins, on the central pipe, to compensate for the low heat transfer coefficient. The prototype finned tube consists of equi spaced fins mounted on the outer surface of tube, in order to locally augment heat transfer between the fin base area & the surrounding fluid. Because heat conducted through fins is very efficient for metals, it results in high fin surface temperature and an increase of total active area.

Index Terms—CFD, enhancement of fin, effectiveness, heat transfer rate

I. INTRODUCTION

The rate of heat transfer to water around a pipe can be greatly enhanced by the use of extended fins. The main objective in improving the performance of thermal system is to enhance heat transfer. To increase thermal performance of water heating boiler, it is necessary & effective to employ extended surface, referred to as fins, on the central pipe, to compensate for the low heat transfer coefficient. The prototype finned tube consists of equi spaced fins mounted on the outer surface of tube, in order to locally augment heat transfer between the fin base area & the surrounding fluid. Because heat conducted through fins is very efficient for metals, it results in high fin surface temperature and an increase of total active area.

Objectives of project study:

1. To determine optimum design specification for water heater.
2. Analysis of water heater with and without fins.
3. To analyzing the shape, size, orientation and spacing of fins for optimum design specifications of water heater.

II. LITERATURE SURVEY

V. N. Kapatkar discovered that the experimental analysis of the results obtained over a range of fin heights and heat dissipation rate. Attempts are made to establish a comparison between the experimental results and results obtained by using CFD software.

Piotr Wais (Poland) discovered that in order to intensify the heat transfer from the heat exchanger surface to fluid, it is possible to increase convection coefficient (by growing the fluid velocity), widen temperature difference between surface and fluid or increase the surface area across which convection occurs. Extended surfaces, in the form of longitudinal or radial fins are common in applications where the need to enhance the heat transfer between a surface and an adjacent fluid exists.

M. Siddique 'Recent Advances in Heat Transfer Enhancements: a says that the way to improve heat transfer performance is referred to as heat transfer enhancement (or augmentation or intensification). Nowadays, a significant number of thermal engineering researchers are seeking for new enhancing heat transfer methods between surfaces and the surrounding fluid. Due to this fact classified the mechanisms of enhancing heat transfer as active or passive methods. Those which require external power to maintain the enhancement mechanism are named active methods. Examples of active enhancement methods are well stirring the fluid or vibrating the surface. On the other hand, the passive enhancement methods are those which do not require external power to sustain the enhancements' characteristics. Examples of passive enhancing methods are: (a) treated surfaces, (b) rough surfaces, (c) extended surfaces, d) displaced enhancement devices, (e) swirl flow devices, (f) Coiled tubes, (g) surface tension devices, (h) additives for fluids, and many others.

Jan Taler discovered that the fin and tube geometry affects the flow direction and has the effect on the temperature changes. Numerical analyses are carried out to examine finned tube heat exchanger. Three dimensional models are performed to find heat transfer characteristics between a finned tube.

III. SOFTWARE SIMULATION

The commercial CFD code FLUENT is used to analyze the model flow characteristics of tube with and without fins. Modeling and mesh generation are however performed in Gambit environment. Water will be taken as the fluid medium. Assumptions :

1. No heat loss from upper and lower surfaces of the tube.
2. No phase change of the water during the analysis.
3. Fluid flow is considered as Laminar.
4. There are no heat sources or sinks in the fin.
5. The thermal resistance between the fin and the base is negligible.
6. The thermal conductivity of the fin material is uniform and constant.

A. Geometry creation

As mention above, in CFD generally 3D,2D analysis is carried out. In our case the geometry is also axis symmetric hence conversion of geometry into simple geometry means simplification of the analysis. The below figure shows the tube without fin

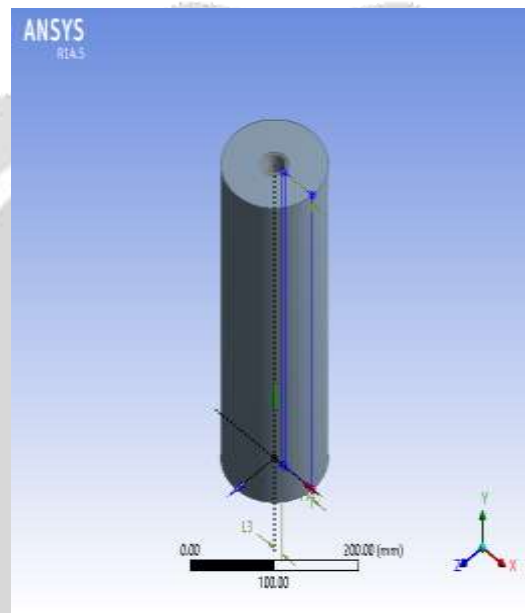

Fig.1.3D Diagram of Tube Without Fin

So for simplicity we convert the geometry into symmetric geometry which is shown in following figure .

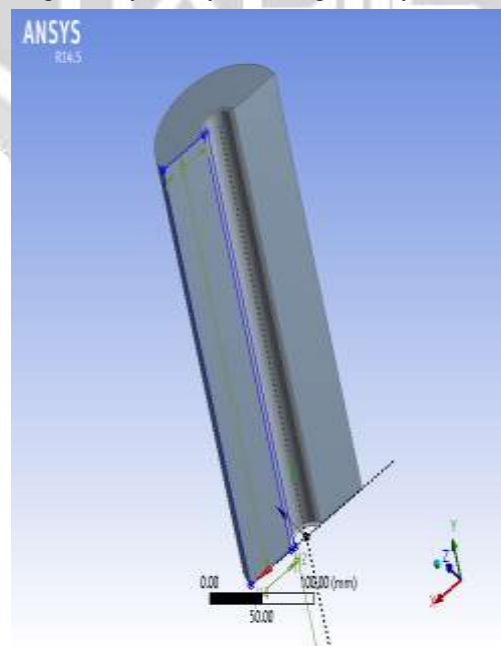

Fig.2.Symmetric Diagram of Tube Without Fin

The below figure shows the axis symmetric tube with fin,

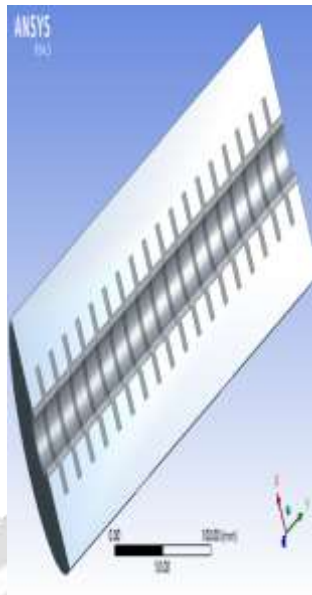

Fig.3.Symmetric Diagram of Tube With Fin

When we talking about the meshing, we must think about the element type, element quality and aspect ratio. For better and accurate analysis the element type must be the quad, element quality must be nearer to the zero.



Fig.4..Mesh Model of Tube With Fins

The setup is important part of the CFD analysis in which we decide the different parameters of the analysis like analysis type, material, cell zone condition and boundary conditions. In this analysis the different parameter is assigned by following way.

Name of Medium	Density Kg/m ³	Sp. Heat j/kgk	Thermal Cond. W/m-k	Visco. Kg/ms
Water liquid	1000(Boussinseq)	4182	0.6	0.00103
Al.	2719 (constant)	871	202.4	-
Copper	8978(constant)	381	387.6	-
M.Steel	7850 (constant)	620	45	-

I. Properties of Material Assigned

Location	Heat Transfer coefficient W/m ² K	Temperature K	Heat Flux W/m ²
Tube Id	-	-	2703.18
Topwall	-	-	-
Bottomwall	19.45	300	-
OuterShell	-	300	-

II. Boundary Condition Assigned at Different Condition

IV. RESULT AND DISCUSSION

The analysis of tube without fins is carried out by giving the boundary conditions as mentioned above, we get the analysis result of tube without fins. Fig. shows that the temperature profile.

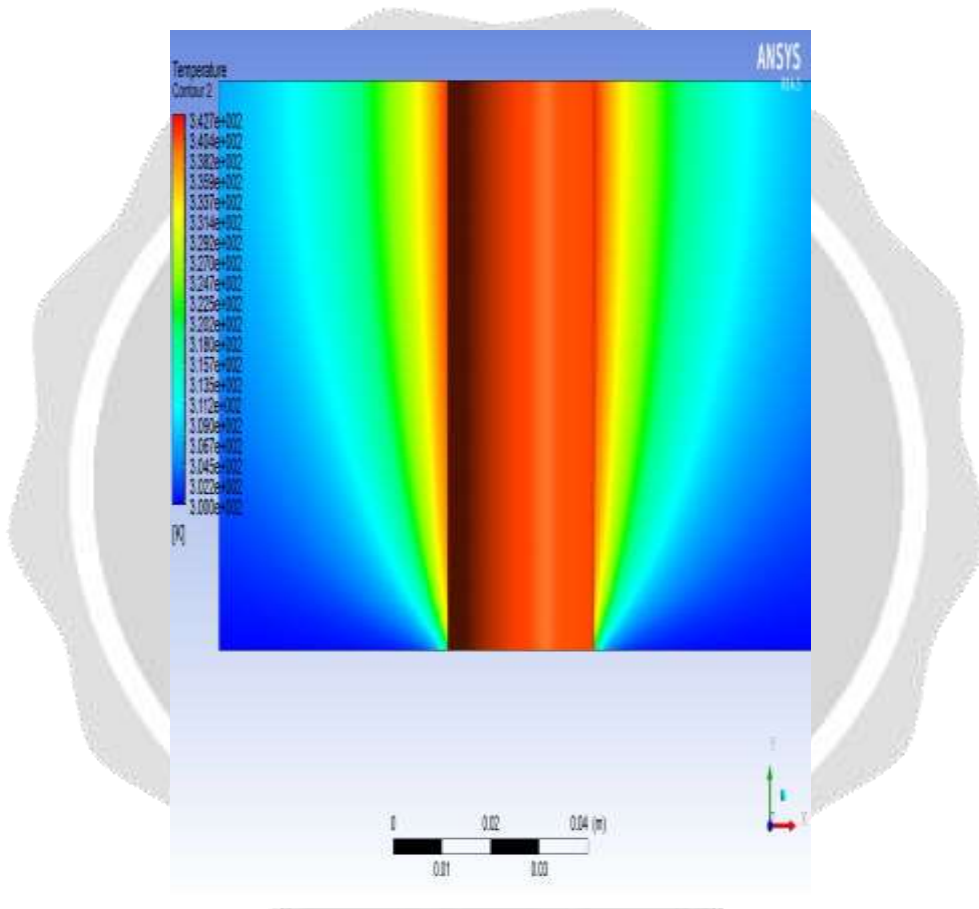

Fig.5. Contours of Total Temperature For Tube Without Fins

Fig.5 shows that the temperature profile which shows that in the absence of fin, water moves along the tube surface only. Middle portion of the water remains at the same temperature. Water which is in contact with tube, get heated. That indicates the heat is not uniformly distributed in the water-liquid zone.

Optimization parameters of fins:

Shape of fin:

As mentioned in the assumption, we only consider fins which are circumferentially mounted. When we think about the shape of the fins then generally three type of fins which are triangular, rectangular and trapezoidal fins. The following figures show the analysis of the these fins

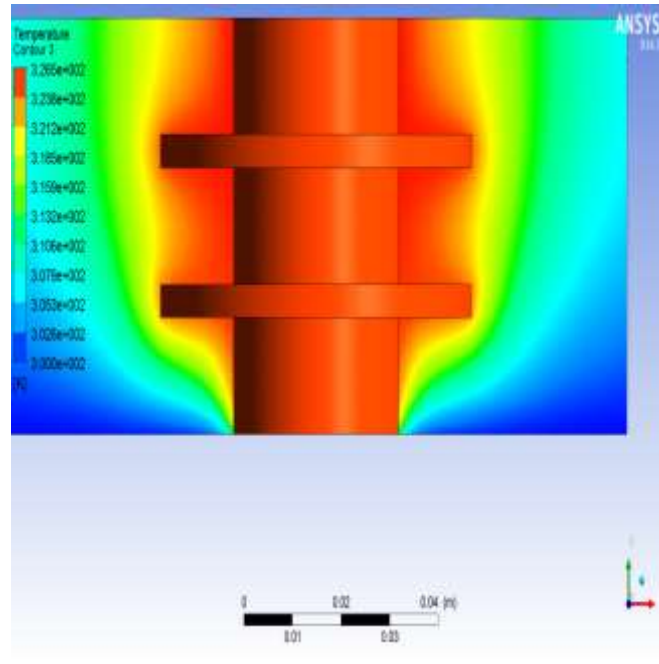

Fig.6.Contours of Total Temperature For Tube With Rectangular Fin

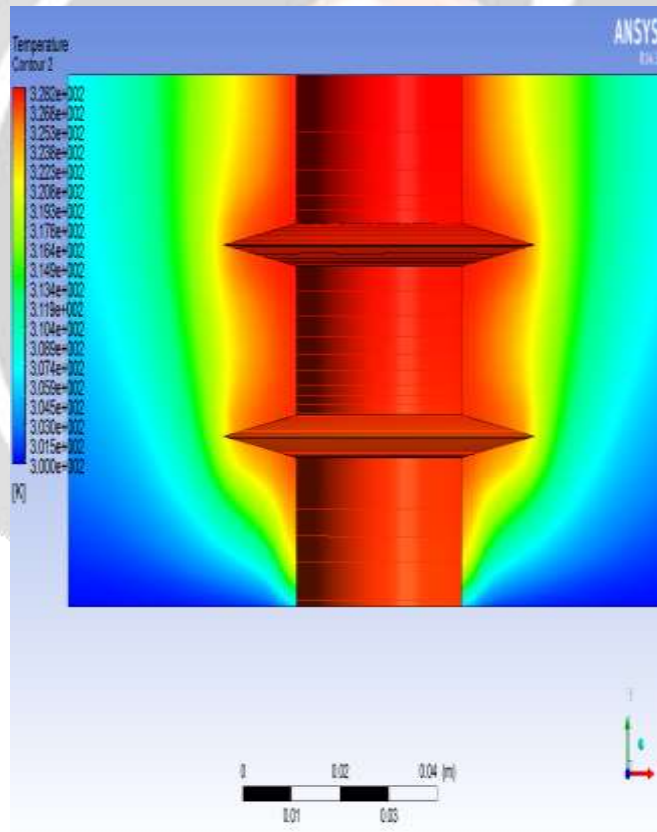
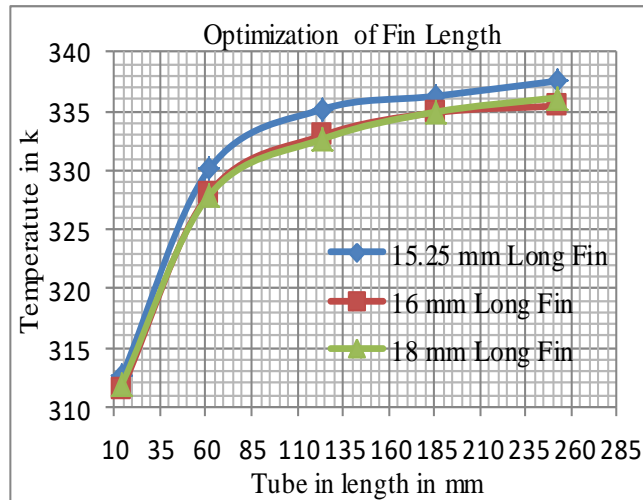

Fig.7.Contours of Total Temperature For Tube With Single Trapezoidal Fin

After analyzing different fin shapes the rectangular fin gives better result as compare to other fin shapes. So selection of rectangular as better for increasing of heat transfer rate. Then next parameter of fin is its length is selected form the comparison of different length fins as per shown in below graph.



Graph No.1..Optimization of Fin Length

After optimizing fin length and fin parameters required to analyzed which fin material can give better result. For this optimization different material are tested and result obtained for different material is as per shown in below table,

Total heat transfer rate (W)	Surface heat transfer coefficient (W/ m ² K) for Aluminium	Surface heat transfer coefficient (W/ m ² K) for Copper	Surface heat transfer coefficient (W/ m ² K) for mild Steel
11	93.68	93.65	93.68
12	97.95	97.996	97.46
13	101.59	101.78	100.69
14	104.85	104.98	104.5
15	107.83	107.98	106.48
16	110.38	110.86	108.93
17	113.76	113.98	112.4
18	115.39	115.96	114.69
19	117.99	118.94	116.91
20	120.86	121.13	118.91

III. Surface heat transfer coefficient and heat transfer rate for different material

From above table the value for surface heat transfer coefficient is less for mild steel as compare to aluminum and copper. Aluminum and copper have nearly same surface heat transfer coefficient for the lower value of the heat transfer rate but by considering cost parameter mild steel is also give close result towards the copper and aluminum material.

By running experimental setup for a some period of time which give different reading of temperature at different location as per following table,

Time in Sec	Fin base	Fin middle	Fin tip	Water base	Water top
0	300	300	300	300	300
100	317.27	315.21	314.1	313.04	315.76
250	322.68	319.09	318.09	316.15	318.96
350	336.89	327.95	327.05	319.88	332.01
500	340.58	336.91	334.94	327.93	340.8

IV. Temperature Variation at Various Location Obtained by Experimental Setup.

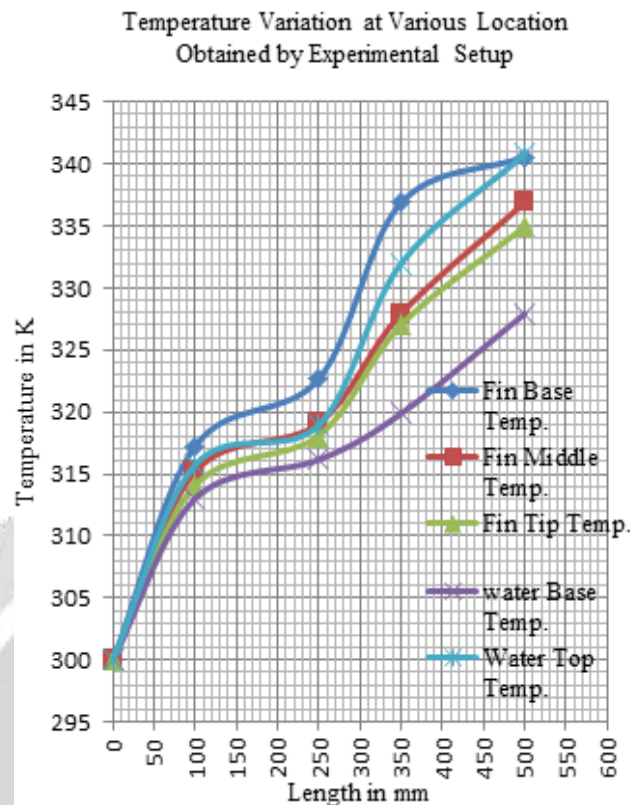

Graph No.2 Temperature (K) Vs Time (sec) for Experimental setup

Comparison of temperature after 500 sec at location 15 mm from tube surface

Tube without fins = 325 K

Tube with fins = 342 K

Nearly about 17⁰C difference occurred in the temperature. Which cause more heat transfer rate in tube with fin.

Therefore from above graphs we conclude that temperature variation is more by using fins as compare to tube without fins. Therefore fins are suitable for increasing the temperature of water.

V. CONCLUSION

Various types of water heating boilers available in market are firstly studied. From that analysis, a water heater is designed and manufactured for finding optimum parameters such as shape, size, cross-section, orientation, spacing etc. of fins by taking inner tube and heater as base parameters. To reduce time and cost of manufacturing, some parameters are also analyzed with the help of CFD software. Following important conclusions are drawn from the work carried out on water heating boiler:

The efficiency of water heater is greatly enhanced due to extended surfaces (fins). Required temperature of hot water is achieved in less time. The amount of energy required for heating the water is reduced which result in saving of energy.

REFERENCES

- [1] Piotr Wais, "Fin-Tube Heat Exchanger Optimization", Journal of Engineering Research and Studies, Vol.II, 2001, page no.345-360.
- [2] Abdullah H. Alessa and Mohammed Q. Al-Odat, "Enhancement of natural convection heat transfer from a fin by triangular perforations of bases parallel and toward its base", the Arabian Journal for Science and Engineering, Volume 34, Number 2B, May 27, 2009
- [3] Narayan K. Sane and Sanjeev D. Suryawanshi, "Natural Convection Heat Transfer from Horizontal Rectangular Inverted Notched Fin Arrays", Journal of Heat Transfer, August 2009, Vol. 131.
- [4] N. Kapatkar, "Computational analysis and optimization for heat transfer through fins with different types of notch", Journal of Engineering Research and Studies, 2011, page no.133-138.
- [5] Shakuntala Ojha, "CFD analysis on forced convection cooling of electronic chips "for the degree of Master of Technology (Research) In Mechanical Engineering, 2009, page no.48-73.

- [6] Jan Taler, "Fin shape optimization in tube heat exchangers by means of CFD program", second International Conference on Engineering Optimization, September 6 - 9, 2010.
- [7] M. R. Chopade, "Experimental and computational analysis and Optimization for heat transfer through fins with different types of notch", Journal of Engineering Research and Studies, Vol.II, Issue I/January-March 2011.
- [8] V.K. Patel, R.V. Rao, "Design optimization of shell-and-tube heat exchanger using particle swarm optimization technique" Journal at Science Direct Applied Thermal Engineering, March 2010.

