

SMART BULB USING IOT

Diksha kamble¹, Sayali Ghude² Shraddha Ingle³, , Shruti Ghagre⁴, Rahul R. Burange⁵

^{1,2,3,4} Students Electronics Engineering, KDKCE, Nagpur, Maharashtra, India

⁵ Assistant Professor, Electronics Engineering, KDKCE, Nagpur, Maharashtra, India

ABSTRACT

This project deals with the design & analysis of the Microcontroller based Smart battery charger specifically designed for multimode operation to ensure no power cut. The main objective of this project is to provide uninterrupted power supply to a load by selecting the power supply from multiple sources such as Mains, Solar Power, Battery Bank and Generator automatically on the basis of their preference. The design and performance analysis of a power factor corrected (PFC), single switch forward buck converter proposes Smart Charger is carried out for low power battery charging applications. The main features of battery charger are low cost, fast charging, high power factor, high efficiency, minimum ripple and high reliability. The concept of this project is the combination of solar power inverter, wireless power transfer concept used for the generation of power and Internet of Things (IoT) based home automation system. The advantage of this project is to provide access to an everlasting and pollution free source of energy. This option is provide to use the system in two possible operating modes; the stand alone mode which is used to satisfy this needs, and the grid connected mode which used to sell electricity to utility when in excess; thus eliminating the need of battery storage.

Keyword: - Internet of things, Sensors, Wireless networks.

1. INTRODUCTION:-

The insistence for electricity is increasing day by day and frequent cuts are causing many problems in various areas like industries, hospitals and houses. The backup arrangement for power source is a must. We are facing many real time challenges in daily activities due to short electricity supply. Even after having electrification, solar panels and backup of different sources, simultaneous functioning of their operations and handling are herculean tasks.

Out of these challenges, important one is availability of electricity which is variable and unreliable. These are economically not available for heavy load since there is a need of excess backup capacity. Also due to fluctuating weather conditions makes the system more vulnerable to power outage.

Objective of this project is to combine the concept of solar power inverter, wireless power transfer concept used for the generation of power and Internet of Things (IoT) based home automation system.

The proposed design concept is used to monitor and control electrical energy consuming devices like switches, bulb, in order to effectively balance energy generation and usage.

The project aims at gathering the energy from renewable energy sources like sun and to effectively use the harvested energy for the benefit of mainly the remote villages (villagers) facing the serious power problems.

2. AIM AND OBJECTIVE

2.1 Aim of the project

Aim of the Project is to modify a simple bulb to such a bulb which will continuously glow and does not depends on only one that is AC power supply and with that it can be controlled through internet.

2.2 Objective of the project

The main and operates in dual mode, supplying independent AC loads or the grid, while minimizing its cost and size. Objective of our project is to design and construct a system that produces electric energy.

The system's main properties are:-

Manufacture of quality electricity from a replicable source to reduce dependence on fossil fuels and the associated emissions of pollutants. Reduce cost of energy consumption by being able connect

1. Bulb can be operated through internet.
2. The schematic of the IoT bulb in the proteus software and test of the remote user interface for the circuit.
3. Integrate secondary source of power, in case absence of AC Supply.

3. PROPOSED WORK

In this project we are going to design multimode uninterrupted Led bulb, which is charge through AC current and DC current, this bulb can control through internet.

LED lighting has recently been promoted as an emerging technology to replace incandescent and fluorescent lamps. This project targets the design methodology for LED lighting systems that may be powered by weakly regulated power grids and AC current. The essence of the project is to highlight the advantageous features of properly designed LED systems as a new generation of smart loads that may adapt to possible voltage and power fluctuations due to the intermittent nature of renewable energy sources.

Examples of applications being considered include public lighting systems such as road lighting. The prime objective is to reduce, as far as possible, the luminous flux variation in the presence of fluctuating mains voltage. The second objective is to adopt reliable lighting technology that has minimum maintenance requirements and long lifetime because public lighting may be subject to extreme weather conditions such as wide temperature changes and lightning.

4. BLOCK DIAGRAM

The general purpose of bulb is only depend on the power supply. We are going to make the system that can continuously provide a power supply to the bulb without any stop. The system of bulb is given below in the figure.

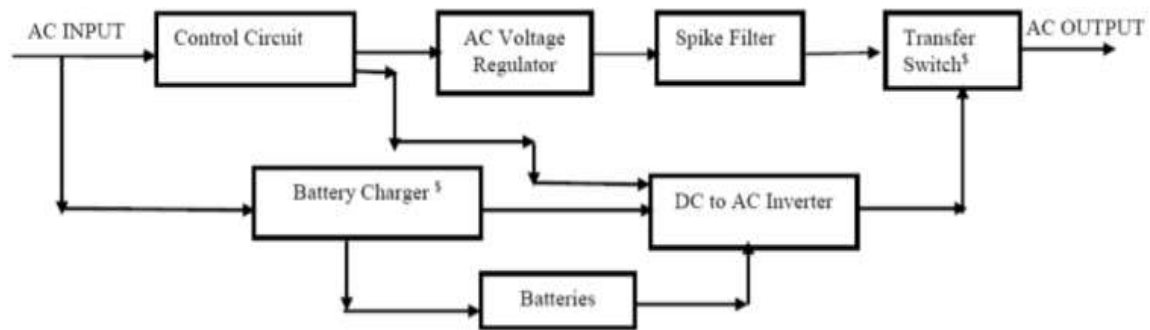

Fig1. Block Diagram

5. CONCLUSIONS

The experimental results shows the developed charger is highly effective and meets the regulatory requirement of emission standards, since it has high power factor with low current harmonics. It also meets green product criteria as it gives priority to renewable energy source and charge battery bank to its utmost capacity by matching the charging current to change in impedance according to charging state.

LED systems to be designed as smart loads that are adaptive to the power and voltage fluctuations of renewable energy systems. Since the power consumption of the LED systems under the design methodology will change with the power profile of the renewable energy source, it is an example of future smart load with load demand following the power generation. Therefore, it has the potential of reducing the energy storage requirements in future smart grids because of the reduction of power difference between the load demand and power generation.

6. REFERENCES

- [1] S. El-Faouri Fares, Munther Sharaiha, Daoud Bargouth, Ayman Faza, "A Smart Street Lighting System Using Solar Energy", IEEE, February 2017.
- [2] Giuseppe Cacciatore, Claudio Fiandrino, Dzmitry Kliazovich, Fabrizio Granelli, Pascal Bouvry, "Cost analysis of smart lighting solutions for smart cities", IEEE International Conference on Communications (ICC), pp. 1-6, 2017.
- [3] Bhagyashree Beeraladinni, Ankita Pattebahadur, Suraj Mulay, Vijay Vaishampayan, "Effective street light automation by self responsive cars for smart transportation", IEEE, February 2017.
- [4] Prabu V Parkash, Dandu Rajendra, "Internet of Things Based Intelligent Street Lighting System for Smart City", International Journal of Innovative Research in Science Engineering and Technology, vol. 5, no. 5, May 2016.
- [5] MENESES Maria, ALBUQUERQUE Manuela, FONSECA Antonio ALVES, CARREIRA Pedro, "ENERGY EFFICIENCY IN STREET LIGHTING — CITIZENS POINT OF VIEW", CIRED Workshop-Helsinki, pp. 14-15, June 2016.
- [6] J. Sherly, D. Somasundareswari, "INTERNET OF THINGS BASED SMART TRANSPORTATION SYSTEMS", International Research Journal of Engineering and Technology, vol. 02, no. 07, Oct 2015.
- [7] Akshay Balachandran, Murali Siva, V. Parthasarathi, Surya, Shriram K. Vasudevan, "An Innovation in the Field of Street Lighting System with Cost and Energy Efficiency" in Indian Journal of Science and Technology, vol. 8, August 2015.