

SMART ROLLING E-NOTICE BOARD USING BLUETOOTH TECHNOLOGY

B.S. kavya¹, K. purnima², R. Meena³, S. Veda⁴, TK. Prasanna⁵

¹ Student, ECE Department, Gandhiji Institute of Science and technology, Andhra Pradesh, India

² Student, ECE Department, Gandhiji Institute of Science and technology, Andhra Pradesh, India

³ Student, ECE Department, Gandhiji Institute of Science and technology, Andhra Pradesh, India

⁴ Student, ECE Department, Gandhiji Institute of Science and technology, Andhra Pradesh, India

⁵ Assistant Professor, ECE Department, Gandhiji Institute of Science and technology, Andhra Pradesh, India

ABSTRACT

This paper presents the overall design of "Smart rolling LED Display using Arduino and Bluetooth" with low cost and user can access multiple applications. If anyone wants to display the message they can send message through using android Bluetooth by using this project. This project deals with advanced wireless Arduino development board. The main objective of this project is to design a wireless board that displays messages sent from android phone user using Bluetooth. The main controlling device of the whole system is Arduino. Matrix LED Display module, Bluetooth module are interfaced to Arduino and android development tool with APK application.

Keyword. *Arduino, bluetooth, matrix LED display, android, APK application.*

1. Introduction

The project aims at designing a LED based scrolling message display controlled from an android mobile phone. The proposed system makes use of Bluetooth technology to communicate from android phone to LED display board. This project is to develop an embedded system, which is used for instant information display using LED's by using android bluetooth module. Now a day's every advertisement or information is displayed digitally. The big shops and shopping centres are using the digital moving/scrolling displays now. In railway station, bus stands everything that is ticket information, platform number etc is displaying in digital moving display. But in these displays if they want to change the message they can send message through using android Bluetooth by using this project. If they want to display messages about something crucial within minimum time, it displays whatever wants. LED displays are used in variety of applications, like store signs, billboards and many more. In recent years it is commonly used in destination signs on public transport vehicles. LED panels are also used for the purpose of general illumination, task lighting and for stage lighting. Display systems are classified into single line displays, and multiline displays. A standard LED display board consists of led lights arranged in 3 sets of 16 rows x 32 columns, with each led placed at a pixel of 5mm. Displays boards of any length and breadth can be made by combining more than one of these standard units. These display units are capable of displaying messages of any kind, including alphanumeric, numbers etc., in static or scrolling formats. This system is comprised of a red colour matrix display panel. It also includes an executive program that runs on the Arduino for the display control of data information on the display board. Led provides several advantages over traditional light bulbs, such as small size and longer life. A red colour led can be used to advertise even day-light conditions. The led display board displays images and messages entered by using a microcontroller

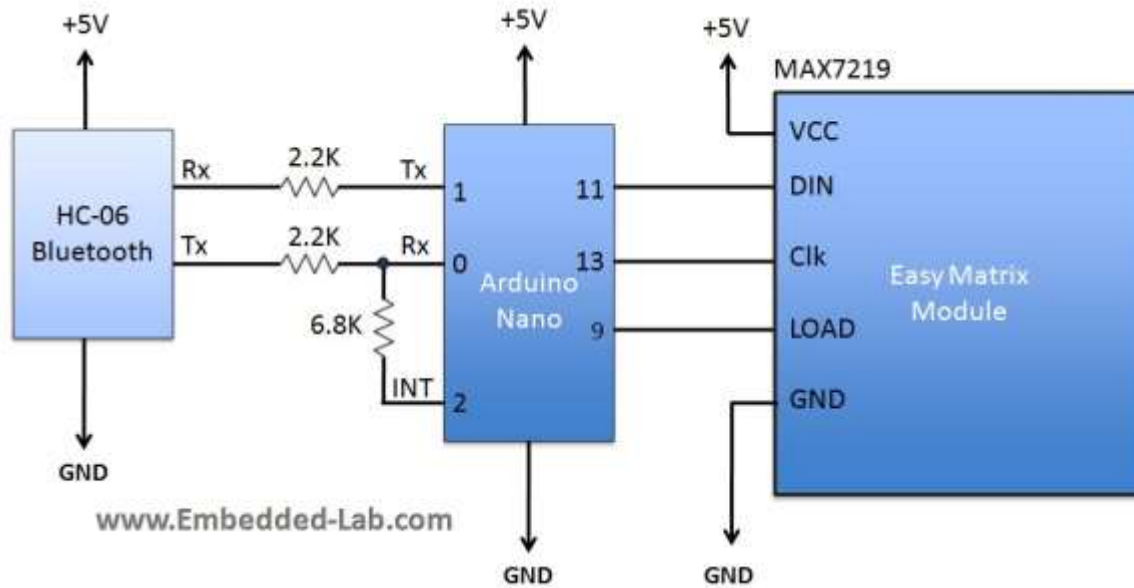

Fig-1: Bluetooth and Arduino board

2. System Description

This system is actually divided in main two parts, one is message transmission section which is android phone and another is reception and displaying section. The Android phone is service which is used to transmit the text message which is to be displayed on LED board. At the input/transmitter side the android phone is used to generate input to the system. The software used is arduino development tool. In that tool APK application is used for sending texts or numbers using Bluetooth access. The message sent by Bluetooth is in the form of ASCII codes. At the receiver side Bluetooth receiver is used. It receives ASCII codes from transmitter and gives to arduino development board which is controlled by AVR controller. The board is connected to 3 sets 16 rows x 32 columns LED display through SPI interface. The LED board displays this message using scrolling technique. So required information displayed on that board.



Fig-2: Bluetooth module

3. Hardware Requirements

Power Supply/SMPS

A 12 volt power adapter is used here which acts as power Supply. It is an important part of a circuit. It provides required supply to different blocks of the circuit from input 230V AC. The main blocks include transformer, rectifier circuit, filter circuit, and regulator circuit. Voltage regulator IC LM7805 is used as a voltage regulator. The microcontroller and other devices get power supply from AC to DC adapter through 7805, 5V regulator. The adapter output voltage will be 12V DC no regulated. The 7805/7812 voltage regulators are used to convert 12 V to 5V/12V DC.

AVR Microcontroller

This is a high performance Atmel 8-bit AVR RISC based microcontroller combines 32KB ISP flash memory with read-while-write capabilities, 1KB EEPROM, 2KB SRAM, 23 general purpose I/O lines, SPI serial port, serial programmable USART, 6 channel 10 bit A/D converter.

Bluetooth (HC-05) module-

It is an easy to use Bluetooth SPP (serial port protocol) module, TTL interface, designed for transparent wireless serial connection setup which can configure as either master or slave.

Ardiuno Development Board

This board is compatible for the message sent by the android phone through Bluetooth. This board consists the main part is AVR controller. This controller processes received ASCII codes and given to the LED display board through SPI interface.

LED Matrix Module

We used here LED matrix module with 5 module connected in cascaded 8 rows x 40 columns to display the scrolling message.

4. CONCLUSIONS

As the technology is advancing every day the display board systems are moving from Normal hand writing display to digital display. Further to Wireless display units. This paper develops a photo type laboratory model wireless notice board system with WIFI MODULE and BLUETOOTH connected to it, which displays the desired message of the user through an SMS in a most populated or crowded places. This proposed system has many upcoming applications in educational institutions and organizations, crime prevention, traffic management, railways, advertisements etc. Been user friendly, long range and faster means of conveying information are major bolsters for this application. By using this proposed methodology we can enhance the security system and also make awareness of the emergency situations and avoid many danger.

5. REFERENCES

- [1] SMS And MMS Interworking In Mobile Networks Arnaud Henry- Labordère , Artech House mobile communications, 2004 - Technology & Engineering.
- [2] Ayala, Kenneth J. (1996), The 8051 Microcontroller- Architecture, Programming and Applications, Delmar Publishers, Inc. India Reprint.
- [3] GSM tele communication standards, June 2000 Second edition, European Telecommunications Standards Institute.
- [4] M Saullah, NS Qureshi, "SMS Repository and Control System using GSM-SMS Technology," European journal of scientific research, 2012. www.wikipedia.org

- [5] "RS232 Tutorial on Data Interface and cables". ARC Electronics. 2010. Retrieved 28 July 2011.C.
H. Papadimitriou and K. Steiglitz, "Combinatorial Optimization: Algorithms and Complexity",vol.1,no.2, pp.
1104- 1108,1982.
- [6] M. Grotschel, L. Lovasz, and A. Schrijver, "Geometric Algorithms and Combinatorial Optimization",
vol.10,no.1, pp. 201-206,1988.7, Aug. 2009.

