

# A LITERATURE REVIEW ON PROTECTION OF LVDC BUS MICROGRID SYSTEM

Prof. Nazneen. K. Choudhari and Prof. Nida. N. Shaikh

Department of Electrical Engineering  
Assistant Professor at BMIT College, Solapur

## Abstract

Low Voltage DC Micro grid Systems have attracted lot of attention in recent years due to its proposed use in smaller micro grids mostly based on renewable energy sources like PV arrays, fuel cells and micro turbines. AC power grids have disadvantages like synchronization issues, reactive power control and bus stability which are overcome in DC grids. However, protection has been a challenge for these dc systems. Several strategies are suggested by researchers to overcome this problem. This paper gives brief about the strategies proposed to protect dc-micro grids by highlighting its relative advantages and disadvantages over one another. A solution is proposed thereafter which gives insight into fault tolerant approach to low voltage dc-bus system thus make it more acceptable.

**Index Terms**— DC distribution, Fault Tolerant System, Micro grids, segment controller

## I. INTRODUCTION

In past few years, many distributed power systems have been proposed by researchers to meet the ever-increasing demand for power and due to introduction newer energy extracting techniques from renewable energy sources like solar PV systems, wind turbines, fuel cells, etc. Energy storage elements like batteries and super-capacitors have also made way into these systems. Distributed power systems have numerous advantages like improved reliability, better efficiency, localized power delivery and hence higher power quality.

Microgrids are networks of smaller distributed power systems which consists of one or many distributed energy sources and loads which can be easily and readily integrated with renewable energy sources. These systems are then classified into ac-bus and dc-bus microgrid systems. The ac-bus systems are advantageous as existing power grid technologies are readily applicable to it but suffer disadvantages like synchronization issues, stability issues and reactive power control to name a few. DC-bus systems have emerged as a winning solution to these problems as they are small, localized and these systems have negligible transmission losses. Moreover, overall cost also reduces compared to typical ac-dc-ac systems. A conceptual diagram of a dc-bus microgrid system is shown in Fig. 1.

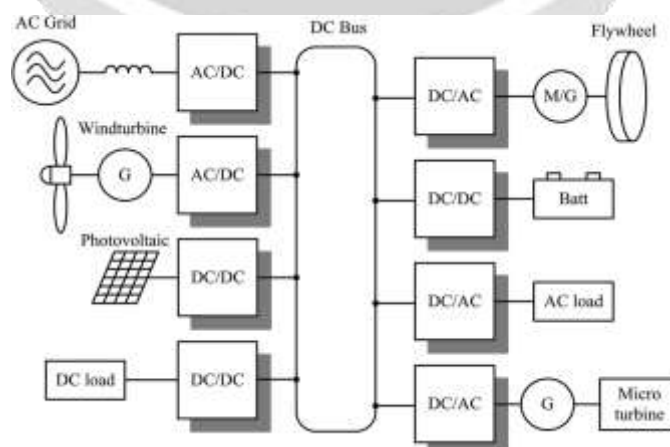

Fig. 1. Conceptual diagram of a dc-bus micro grid system.

Though there are several advantages of these systems, these systems have great challenges in its protection like breaking of a dc arc, fault location detection, and lack of protective equipment. Moreover, there are less standard guidelines, and maintenance personnel lack experience with these systems, hence these systems pose a problem for protection. Many solutions have been proposed by various authors and researchers for this problem. This paper investigates probable solutions through a robust literature survey on this topic and suggests a fault tolerant and robust system so that in event of fault, instead of entire system to be shut down, only a partial system is shut down for maintenance and rest of the system continues to operate without any problem.

## II. EXISTING SYSTEMS

There are many protection systems that are prevalent in the dc-bus based micro grid systems. These systems are highlighted in this section and their advantages and relative disadvantages are listed along with brief explanation of the system.

In [2], a LV dc micro grid protection system is designed to protect the system and connected distributed sources and sensitive electronic loads. Authors suggest that an LV dc micro grid must be connected to an ac grid through converters with bidirectional power flow and, therefore, a different protection-system design is needed. The scheme proposed also considers the influence of different grounding methods on protection of dc micro grid.

Advantages:

- It is possible to use available devices in this scheme for protection.
- Existing grounding methods are used which prevent additional costs.

Disadvantages:

- Problems may arise with high-impedance ground faults which can be difficult to detect.
- Method is still in its research phase.

Paper [3] describes practical protection solutions for the LVDC network and presents an LVDC system laboratory prototype in which experimental testing is performed. Experiments are performed using a DSP based PSpice platform considering all the important aspects of the actual system.

Advantages:

- Experiments are performed on a prototype model and hence give real insight on the problem of protection.

Disadvantages:

- Some differences are found in actual system and prototype designed in the paper.

In [4], authors have developed a DC power distribution network which is more suitable for industrial manufacturers and can be used in aircraft/ship power distribution due to its numerous advantages like higher efficiency and less power losses in conversion stages. They suggest that low shortcut impedance will cause high current rising rate, which can bring heat, arc and electrical force damage to the DC power distribution grid in a quite short time that the DC breakers hardly act. A solid-state Fault Current Limiter (FCL) using a combined power switch which gives faster response is proposed to reduce fault current in this method.

Advantages:

- Actual experimental results indicate the successful implementation of the proposed scheme.
- During normal or non-faulted system, power losses are minimal.

Disadvantages:

- Fault current limit must be operated in a low temperature range.
- Overall system cost makes it impracticable to be used widely across the network.
- Size of the system is large enough to make it impracticable.

In [5], a new approach for protecting DC power distribution circuits against faults and negative incremental impedance instabilities. Authors mention a circuit breaker like device which remains passive until a fault occurs. Unlike a circuit breaker, the device operates in current limiting mode or in impedance transformation mode, according to the system requirements, and it can serve as a power buffer during transient upstream disruptions. The approach permits coordination

between hierarchical levels of protection, it enables system reconfiguration, and it increases system stability. All three types of protection are achieved automatically by the controller based solely on local current and voltage measurements.

Advantages:

- The efficacy of this solution has been demonstrated through simulation.
- System stability with and without the proposed protection system has been analyzed according to the Bryton-Moser mixed potential criterion. The approach is proven to increase the stability of the systems in all configurations.

Disadvantages:

- The proposed system lacks experimental verification.
- Overall cost of the system makes it impracticable for actual use in the real system.

In [6], a ring type DC micro grid system is considered. Authors propose a method which isolates only the faulted section of the micro grid system than shutting down the entire system in the event of fault. They propose an algorithm which senses the fault using differential current method and then current derivative is take for segment isolation.

Advantages:

- Entire grid does not need to be shut down as the proposed system can isolate the faulted section.
- Differential current band method is widely accepted method for fault identification.

Disadvantages:

- Proposed method is only limited to simulation study using MATLAB/Simulink and no practical verification is done.
- After detection, isolation is done using breakers which are un-operational in case of severe faults and thus need to be better taken care of.

In [7], an improved RCD snubber for solid-state circuit breaker (SSCB) is proposed for a low voltage DC micro grid to protect the SSCB against over voltage caused by its tripping at the occurrence of a DC-bus fault. Commonly, snubber capacitor absorbs the fault energy and is limited to its small capacity. Hence, authors have created a diode-resistive path separate from the snubber capacitor to act as a power dissipater which can exhaust the fault energy very fast. Thus, capacitor value can be kept same and over voltage can be easily and quickly suppressed.

Advantages:

- Improvements in RCD snubber circuit keeps the value of capacitor used to a normal value and still can suppress huge over voltage and dissipate power very quickly.
- This also prevents the circuit breakers and relaying mechanism from the effects of chattering during quenching of the dc arc.

Disadvantages:

- Fault detection algorithm for the proposed technique is not given in this paper.
- Verification of the proposed strategy is only limited to simulation study and it lacks experimental verification.

In [8], authors state that because of the multiple power sources involved, fault protection is one of the most critical issues in micro-grids. If a micro-grid including a PV installation is connected to the grid by means of a front-end converter, multiple possible cases of fault may occur. It is a typical feature of such configuration that, depending on fault resistance and location, fault currents from the AC grid may pass unlimited through the converter and contribute to the fault. They also state that most general-purpose converters are not able to interrupt fault currents in all situations. A specific protection system is then required to ensure fault clearance and maintain safety. Then they conclude that two types of protection systems can be used in such scenarios, one being solid-state circuit breakers and other being electro-mechanical devices complemented by front end converter design modification.

Advantages:

- Solid-state circuit breakers can limit let-through energy to protect both the DC grid and front-end converter.
- With use of protection as discussed in this paper, oversizing of the diodes of converter can be avoided.

Drawbacks:

- Traditional DC circuit breakers cannot be equipped with the proposed strategy and hence need to be replaced entirely which will increase unnecessary cost of small micro grid systems.

- Solid state breakers are futuristic and hence practical realization may take lot of time before the strategy is used in real life scenario.
- Developed strategy is run through simulations and experimental validation is still under question.

In [9], authors have investigated that the conventional protection scheme for DC micro grid uses circuit breaker on AC side, on occurrence of fault AC circuit breaker opens and this cause's complete shutdown of DC link and introduces a forced outage in the system. They present an autonomous scheme for protection of DC grid which avoids the complete shutdown of the DC link and continuity of supply is maintained through other buses, as ring type distribution is considered. This system uses current sensors and controller for fault detection and isolation, whereas diode and resistors are used for fault current extinction, as fault current is harmful for converters. After fault, current difference between sending and receiving end occur based on which the controller isolates the faulted section through power switches/IGBT.

Advantages:

- Segmented isolation is possible in this scheme.
- Approach is more robust than other approaches studies till now.

Disadvantages:

- The efficacy of the said scheme is verified through MATLAB Simulink and lack experimental proof of concept.
- Segment controller design needs to be explained further in detail as information regarding its implementation from practical point of view is missing in the paper.

In [10], researchers focus on more recent approach using the Z-source circuit breakers for protection in DC-bus micro grid system. This is a relatively newer invention and still is quite popular in inverter category. Authors suggest that design of the breaker has been the very focus of research until this point and not its control. In simpler systems, wherein only a single source is connected to a single load, these breakers do not need a complicated control but in MVDC ring type systems, control become very important. For ease of implementation, the construction of this system has been broken down into three stages. During each stage, a different aspect of the system and the breaker's performance is observed and tested. Also, a prototype enclosure for z-source breaker is designed and initial testing results are presented in this paper.

Advantages:

- Z-source circuit breakers are fast to respond to fault elimination.
- Excess current produced in faulted conditions is absorbed by the source capacitor and hence arc extinguishes rapidly.

Disadvantages:

- The control scheme requires all the breakers to communicate with a central control. So, a robust communication mechanism is very much essential for the scheme to function properly.
- The scheme is still under its initial stages of development and may take years to implement it on a real system.

### III. PROPOSED SYSTEM

To overcome the disadvantages of all the existing systems studied in section II and keeping their plus points under consideration, a more practical and cost-effective approach is presented in this section based on research findings as per [1]. In this paper, the scheme is set to attain a few goals. The goals of the proposed scheme are to detect the fault in the bus between devices and to isolate the faulted section so that the system keeps operating without disabling the entire system. To achieve these goals, a loop-type dc-bus-based micro grid system, which has a segment controller between connected components, is proposed by the authors. The segment controller consists of master and slave controllers that monitor currents and control the segment separation, which include solid-state bidirectional switches and snubber circuits. This system can detect faults on the bus regardless of fault current amplitude or the power supply's feeding capacity which is not possible in all other schemes. The authors have tested the proposed concepts using OrCAD/PSpice simulations and experiments on hardware test bed.

A novel protection scheme is proposed for the dc-bus micro grid system. Instead of shutting down the whole system or limiting the bus current, the proposed scheme detects the fault and separates the faulted section so that the rest of the system keeps operating. For such operation to take place, a loop-type dc bus is suggested by the authors to make system robust under faulted conditions. They suggest that loop-type bus has a good system efficiency especially when the distribution line is not long.

The entire loop is divided into a series of segments between subsystems. Each segment consists of a section of bus (positive and negative lines or positive line and ground) and a segment controller. The conceptual diagram of the proposed protection scheme is shown in Fig. 2. The protection system is shown only in segment A, and controllers on other segments are omitted. The protection system consists of one master controller, two slave controllers, and freewheeling branches between each line and ground. The slave controllers read the current at each end of the bus segment connecting two components and send it to the master controller. They also operate the bidirectional solid-state switches on the bus segment and the freewheeling branch according to the commands from the master controller. During normal operations, the currents measured at each end of the bus segment should be nearly identical and the master controller sends commands to put the bus switches on normal positions.

The master controller monitors the difference of two current readings of slave controllers in a segment

$$i_{diff} = i_{in} - i_{out} \quad (1)$$

where  $i_{in}$  and  $i_{out}$  are the line current at each end of the bus segment. When the difference exceeds the threshold, the controller sends the appropriate commands to slave controllers so that the faulted segment can be separated from the system. The RCD snubber circuit is used in this scheme to eliminate chattering and to dissipate energy from the fault current. This also suppresses the over voltage that occur on the circuit breaker during faulted conditions.

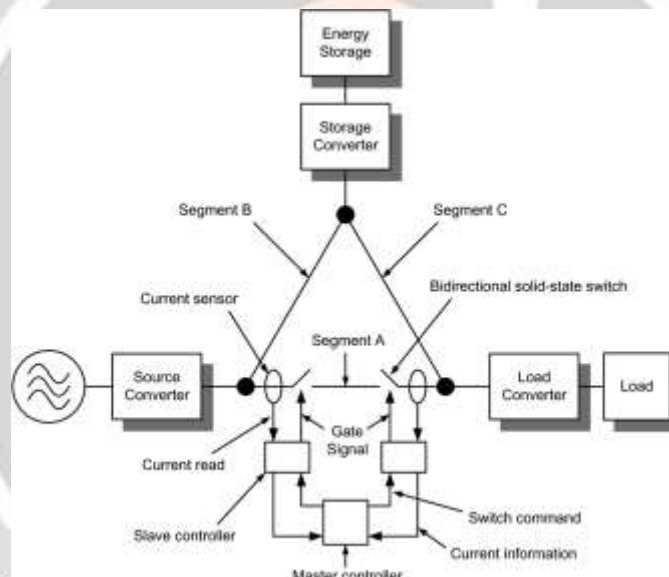

Fig. 2 Conceptual diagram of the proposed protection scheme. Protection controllers in segment B and C are omitted.

#### IV. CONCLUSION

In this paper, the literature survey on low voltage DC-bus micro grid protection schemes is presented. Various schemes and strategies were studied and the relative advantages and drawbacks of each scheme was highlighted along with the brief discussion on the scheme. These points made it clear that a more robust scheme for protection of the low voltage DC-bus micro grid system was needed. Hence an approach based on loop type DC-bus system was suggested and a novel protection system for the same was discussed in brief in section III. It was concluded that instead of shutting down the entire system, isolation of the segment under fault was more beneficial in keeping the system running and reap the benefits of such systems. Further it can be stated that RCD snubber circuits were essential in suppressing the over voltage occurrences during fault conditions and to dissipate energy of fault current. It can be concluded that after a complete survey of research papers on the topic, the proposed scheme is by far the best suited scheme to achieve the set goals of the protection system and can be used in practical scenarios.

**REFERENCES**

- [1] Jae-Do Park, and Jared Candelaria, "Fault Detection and Isolation in Low-Voltage DC-Bus Microgrid System", *IEEE Transactions on Power Delivery*, Vol. 28, No. 2, pp. 779-787, April 2013.
- [2] Daniel Salomonsson, Lennart Söder, and Ambra Sannino, "Protection of Low-Voltage DC Microgrids", *IEEE Transactions on Power Delivery*, Vol. 24, No. 3, pp. 1045-1053, July 2009.
- [3] P. Salonen, P. Nuutinen, P. Peltoniemi, and J. Partanen, "LVDC distribution system protection: Solutions, implementation and measurements," in *Proc. 13th Eur. Conf. Power Electron. Appl.*, pp. 1–10, 2009.
- [4] F. Luo, J. Chen, X. Lin, Y. Kang, and S. Duan, "A novel solid state fault current limiter for DC power distribution network," in *Proc. IEEE 23<sup>rd</sup> Annu. Appl. Power Electron. Conf. Expo.*, pp. 1284–1289, Feb. 2008.
- [5] Ugo Ghisla, Igor Kondratiev, Roger A. Dougal, "Branch circuit protection for DC systems," *2011 IEEE Electric Ship Technologies Symposium*, pp. 234-239, Alexandria, VA, 2011.
- [6] Aswani J and P. Kanakasabapathy, "Protection of a low-voltage DC ring microgrid system," *2016 International Conference on Energy Efficient Technologies for Sustainability (ICEETS)*, pp. 17-22, Nagercoil, 2016.
- [7] Wenjun Liu, Hua Yang, Fei Liu, Jianjun Sun and Xiaoming Zha, "An improved RCD snubber for solid-state circuit breaker protection against bus fault in low-voltage DC microgrid," *2015 IEEE 2nd International Future Energy Electronics Conference (IFEEEC)*, pp. 1-5, Taipei, 2015.
- [8] M. Carminati, S. Grillo, L. Piegari, E. Ragaini and E. Tironi, "Fault protection analysis in low voltage DC microgrids with PV generators," *2015 International Conference on Clean Electrical Power (ICCEP)*, pp. 184-191, Taormina, 2015.
- [9] G. Patil and M. F. A. R. Satarkar, "Autonomous protection of low voltage DC microgrid," *2014 International Conference on Power, Automation and Communication (INPAC)*, pp. 23-26, Amravati, 2014.
- [10] A. Maqsood, Lu Li and K. A. Corzine, "Low-voltage Dc testbed design for a Z-source breaker based protection scheme," *2016 Clemson University Power Systems Conference (PSC)*, pp. 1-6, Clemson, SC, 2016.