

# A MITIGATION OF VOLTAGE FLUCTUATION ON SMALL SCALE INDUSTRY

Rohit Sontakke<sup>#1</sup>, Vikrant Shrirame<sup>#2</sup>, Apeksha Dhengre<sup>#3</sup>, Rasika Bondre<sup>#4</sup>, Yugant Tidke<sup>#5</sup>, Govinda Hedau<sup>#6</sup>

*#Electrical Engineering, Rashtrasant Tuldoji Maharaj Nagpur University*

## Abstract

*Power Quality plays major role in power system technology. Power quality contains terminologies called voltage sags, swells, interruptions etc. Sources of sags and interruptions are related to power system problems. Voltage interruptions are generally caused by faults on any utility system. Poor quality or fluctuating power supply can often cause power surges, sags, spikes and voltage interruptions. Voltage interruption can be reduced by regulating the constant power supply. The objective of this paper, is to regulate the voltage when the voltage fluctuates as the load changes to make output voltage to constant level. This work is based on small model to describe voltage fluctuation behaviour on the single phase supply.*

**Index Terms:** *Power Quality, Voltage Fluctuation, Voltage Stabilize*

---

## I. INTRODUCTION:

Fluctuation is an important index in the power quality. Many undesirable effects on domestic as well as industrial apparatus can be generated due to voltage fluctuation of the electrical power supply. Over voltage fluctuation can cause harm to costly electronic and electrical equipment like T.V. sets, refrigerators and other scientific and medical equipment etc. This paper presents the solution and method to solve the problem of voltage fluctuation. The work is based on small model of voltage stabiliser to stabilise the voltage. To reduce the fluctuations voltage stabilizers are used in order to protect them from damage.

The voltage stabiliser provides an output voltage with a certain limit for supplying to load irrespective of wide fluctuation in the input voltages, independent of load power factor and without introducing harmonic distortion. The voltage regulator adjusts automatically the voltage variation weather high or low to the proper voltage level necessary for the safe operation of equipment.

## II. CAUSES OF VOLTAGE FLUCTUATION :

There may be different causes for poor quality power supply. Voltage fluctuation can be caused by loose or corroded connections either at the house or on the power lines. Overloading results in low voltage on the network, loosing of connections, or very small a conductor wire carrying power to the house or small scale industry may resulting dimming of the lights. In extreme cases, electric shock also takes place from metal machinery and surface in the industry. Power surges and spikes are also important terminology in power quality, which is due to lightening power switching on the lines, trees touching to the line, birds on the line etc.

### III. MITIGATION TECHNIQUE:

There are various ways to reduce voltage fluctuation, some of these are listed below:

- Tap Changing Technique- Voltage should be kept constant, but this technique varies output voltage between 25-30 V.
- Servo stabilizer Technique- It takes 2 to 3 seconds to make voltage constant. Also wear and tear occurs due to mechanical action and thus results in higher maintenance cost.
- Phase Controller Technique: Phase Controller Technique come with faster correction rate, helping them to work over a wide range of input voltage distortion and also increase the efficiency and decrease the maintenance cost.

So tap changing and servo stabilizer technique has its own disadvantages. Thus we use phase controller technique due to its fast working operation.

### IV. VOLTAGE STABILIZER :

Figure 1 shows voltage stabilizer model. Voltage Stabilizer is a system designed to maintain a constant voltage level. Depending on the design it may be used to regulate one or more AC or DC voltages. Stabilizer stabilises the AC voltage. Sometimes a variation of voltage or spikes appears on an AC line. If we use this then the extra high voltage or low voltage can cause no problem to the appliances. It protects any devices connected to it from getting damaged.



**Fig 1: Voltage Stabilizer Model.**

### V. BASIC COMPONENTS OF VOLTAGE STABILIZER :

Basic components of voltage stabilizer are as follows:

Load – Inductive and resistive type of load are used.

Potential Transformer – 6-0.6 V AC step down transformer, used to measure the output voltage across the load.

Power Transformer – 12-0.12 V AC step down transformer, used to convert 220 V AC to 12 V AC.

Driver IC (ULN 2003) – It is used to drive a relay which convert 5V DC to 12 V DC.

0Regulator IC (7805) – 12 V DC to 5 V DC, it is designed to automatically maintain a constant voltage level, where they stabilize the DC voltage used by the processor and other element.

Opto Coupler (MOC 3021) – An opto coupler are designed to provide complete electrical isolation between the input low voltage side and output high voltage side.

Liquid Crystal Display (LCD) – LCD screen is an electronic display module and find a wide range of application.

TRIAC (BTA16) – These are static device used to switch.

Zero Crossing Detector (ZCD) – It is used to detect the sine waveform transition from positive and negative, that coincides when the input crosses the zero voltage condition.

Relay (12 V DC, 50-60 Hz) – Relay is used to protect the device in fault condition.

Voltage Divider – It converts the voltage at 5V if voltage is more.

Crystal Oscillator – It is used to generate random frequency.

Suppressor Capacitor – It is used to equate the random frequency.

Bridge Rectifier (12 V AC to 12 V DC) – A bridge rectifier, which convert an AC voltage into pulsating DC voltage.

Filter capacitor, resistor, transistor, microcontroller PIC16, ceramic capacitor are other components used to design the stabilizer.

## VI. WORKING OF MODEL:

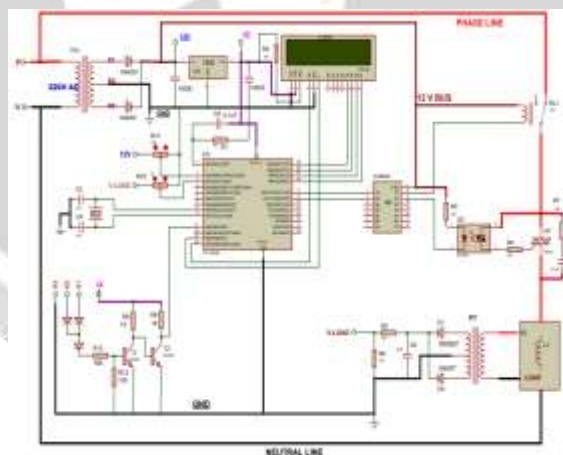

**Fig 2: Circuit Diagram of Voltage Stabilizer.**

Figure 2 shows the circuit diagram of voltage stabilizer. Model of voltage stabilizer is shown in the above figure. In the model, we are using microcontroller PIC16, because it is more advantages as there is no additional circuit required for A to D convertor and also power consumption is less than other. PIC16 operates on 5V DC, for generation of 5V DC step down centre tap transformer of 12 – 0.12 V is used. As transformer transform AC to AC only, but circuit require DC hence rectifier diode D1D2 are used with filter capacitor C1 which reduces the ripple and gives a pure DC of 12V.

Further this 12V DC gives to regulator IC 7805 which is series regulator and maintains its output voltage to constant of 5V irrespective of input voltage. After getting power ON the controller diode the output voltage across the load with the help of PT. This is again step down transformer of 6 - 0.6V, PT's output further converted into DC with another rectifier and filter with voltage divider. Controller check the interrupt occur at

every change in positive and negative half cycle of sine wave with the help of zero crossing detector made by transistor T1 and T2. T1 is a pre-amplifier and T2 is a power amplifier which converts a pre-amplified output from T1 to a digital pulse of 2m/s of 5V.

Once microcontroller gets interrupt from ZCD it gives the trigger signal to the TRIAC, as TRIAC operates on high voltage and there are lots of chances of internal short circuit which may damage the triggering port of microcontroller. Hence for providing a 100% electrical isolation a opt coupler is used to give triggering pulse to TRIAC. Once TRIAC is fired it will automatically OFF after the commutation voltage falls down less than 0.7V. A driver IC (ULN 2003) is used to drive a relay which disconnects a output load in case of fluctuation. As relay is operates on 12V and it requires 80mA, but controller gives a maximum of 5V/20mA in it's output. Hence we have to increase the voltage level from 5V-12V, a diver circuit which comprises of Darlington pair is used. All the parameters like output voltage, input voltage will be displayed on 16\*2 LCD, which connected in 4 bit mode with the controller. In 4 bit mode with the microcontroller, 4 bit configuration reduces the pin requirement for interfacing. In such mode LCD can be interface on single port only.

**VII. FIRING ANGLE CALULATION:**

Thyristor is a controlled switch. It does not get turn on as soon as anode voltage becomes greater than cathode voltage as it in diode. To start conducting the thyristor, it needs two conditions simultaneously mentioned below:-

1. Voltage at anode greater than cathode
2. Gate signal (current injection in gate).

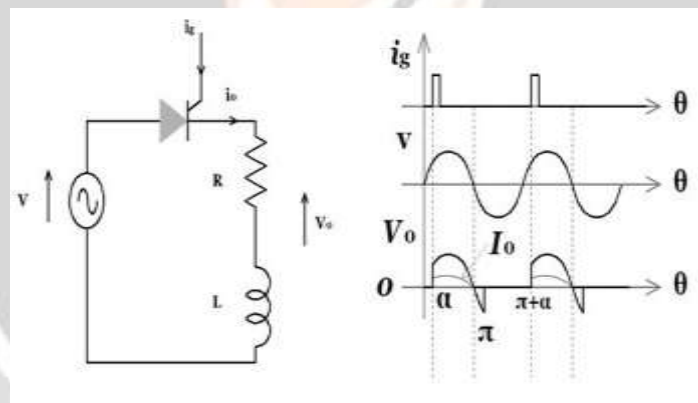

**Fig 3: Firing Angle Concept**

Waveform illustrate firing angle concept in the figure 3. For  $t > 0$ , anode voltage is positive at but both  $I_o$  and  $V_o$  are zero it is because thyristor is not conducting in absence of gate signal.

Now after some time  $t$  (or  $\text{angle} = 2\pi t/T$ , where  $T$  is time period of input sine wave) , gate is fired with current pulse. As soon as gate is fired, both conditions for turning on of thyristor are fulfilled and it gets turned on and current starts flowing in circuit.

Now angle at which thyristor gate is fired is called firing angle  $= 2\pi t/T$ . To turn on thyristor only a small pulse is required at gate but now to turn it off you need to make its current less than holding current value.

$$\text{sqr}((2\pi - 2*2.26 + \sin(2*2.26))/(4\pi))$$

$$V_{load} = 325V * \sqrt{((2\pi - 2*r + \sin(2r)) / (4\pi))} = 325V * 0.249 = 80.9V_{rms}$$

### VIII. CONCLUSION:

In this paper comprehensive study of voltage fluctuation has been done by using phase control technique i.e. Voltage Stabilizer. We had studied the need of constant voltage supply for working of electrical equipment. The overall conclusions are:

- Keep the voltage of power supply to its constant level.
- Carefully adjust the output versus input so that the relay just gets activated to protect the load from very high or low voltages.

### REFERENCE:

- [1] R. C. Dugan, M. F. McGranaghan, S. Santoo, and H. W. Beaty, "Electrical Power Syatem Quality", 2<sup>nd</sup> ed. McGraw-Hill, 2002.
- [2] IEEE Std. 1453-2004, IEEE Recommended Practice for Measurement and Limits of "Voltage Fluctuations and Associated Light Flicker on AC Power Systems", 2005.
- [3] A. A. Girigis, J. W. Stephens, and E. B. Makram, "Measurement and prediction of voltage flicker magnitude and frequency", IEEE Trans. Power Del., vol. 10, no. 3, pp. 1600-1605, July 1995.
- [4] H. J. Kim, K. C. Seong, and J. W. cho et al., "3 MJ/750 kVA SMES system for improving power quality," IEEE Trans. Applied Superconductivity, vol. 16, no. 2, pp. 574-577, 2006.
- [5] <http://spectrum.ieee.org/energy/renewables/winnwe-super-chaged>.

