

A NEW TOPOLOGY OF CASCADED MULTILEVEL INVERTER WITH SINGLE DC SOURCE

G.Kumara Swamy¹, R.Pradeepa²

¹ Associate professor, Dept of EEE , Rajeev Gandhi Memorial College, Nandyal, A.P, India

² PG Student [Power Electronics], Dept of EEE, Rajeev Gandhi Memorial College, Nandyal, A.P, India

ABSTRACT

Multilevel inverters have become more popular in electric high power and medium voltage applications due to fewer disturbances and obtains the quality power. This paper presents a new topology of a multilevel inverter with single DC source and high frequency cascaded transformers to reduce the harmonics and obtain a high output voltage from less input voltage. The proposed topology uses Voltage Source Inverters, which are controlled by using Carrier Based Phase Shift PWM technique. Simulation and Comparison can be studied using MATLAB/SIMULINK for the proposed inverter and other topologies.

Keyword:- Cascaded multilevel inverter, multilevel inverter, single DC source, Voltage Source inverter.

1. INTRODUCTION

In recent years, many industrial applications require higher power applications and some motor drives and utility applications require medium voltage and power. As a result, multilevel inverters has designed to achieve the high power and medium voltages, and these inverters are applicable to Power Grids, Electric vehicles, Batteries, and renewable energy sources.

The concept of multilevel inverter [1]-[4] had begun in 1975 as to overcome the disadvantage of two-level inverters (Voltage source inverters which produce two level output i.e. +Vdc and -Vdc having more ripple content) and also reduce the ripples in the output voltage. A multilevel inverter not only achieves the high power but also reduces the $\frac{dv}{dt}$, EMI problems and soon. A multilevel inverter uses high switching frequency pulse width modulation technique which gives the higher output voltage.

Multilevel inverters can be basically classified into three topologies.

- 1) In Neutral Point clamped multilevel inverters (NPCMLI), [5] the DC source voltage can be converted into capacitor voltage and the number of levels is increased by increasing the number of diodes and diodes are used as clamping devices. The advantages of using this topology are it can be operated in SDCS, requires fewer components due to the usage of fewer capacitors and thereby reduces the overall cost of the multilevel inverter. The disadvantages are obtained limited output voltage and for more than three levels the capacitor unbalancing occurs and efficiency decreases.
- 2) In capacitor clamped multilevel inverters [4] [6] [7], the number of levels are increased by using the capacitors and these are also called as Flying capacitor multilevel inverters as the capacitors charge float on the earth potential. It overcomes the disadvantages of NPCMLI by using the capacitors as clamping diodes. Capacitors can be pre- charged before using it in an inverter. To provide the balanced configuration, only one switch should be ON at a time. The advantages of capacitors clamped MLI are analyzing of the branch should be independent, voltage balancing of the capacitor and gives better power quality performance. Capacitor pre-charging is difficult in capacitor clamped MLI.
- 3) The Cascaded H-Bridge multilevel inverters (CHBMLI) [4] [8]-[10] are the basic, well – known and most commonly used multilevel inverters which are applicable to many applications as it requires less number of components when compared to other topologies. This multilevel inverter consists of H-bridge cells or modules

which are connected in series as shown in the below fig: 1 to produce the stepped output voltage waveform. The Stepped output voltage is obtained by increasing the number of H-Bridge cells and then the harmonics can be reduced to obtain the quality power. Each H-bridge cells consists of DC source with four switches to obtain the three phase output voltage i.e., +Vdc, 0, and -Vdc.

Features of MLI:

Real power flow can be controlled as the structure is having separate DC sources.

Harmonics can be reduced and triple harmonics are eliminated.

Real time switching i.e., the switching time is zero.

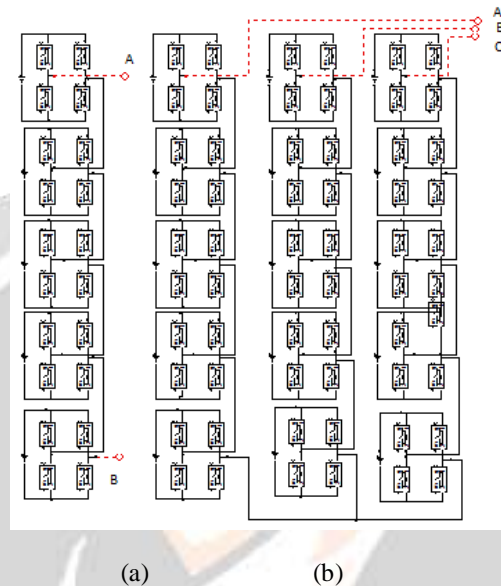

Fig: 1. Cascaded H-Bridge multilevel inverter for 11-level (a) per single phase (b) per three phase

The advantages of cascaded H-Bridge MLI's are the usage of less number of components, size and cost are reduced because they do not need capacitors and diodes, Total Harmonic Distortion (THD) is also reduced, high power quality both real and reactive power flow is controlled. Due to these features, the cascaded H-Bridge MLI's are used in various applications such as in Batteries, Variable Speed drives, Induction motors, Static Var compensation, power grids, and Flexible AC transmission systems and so on. For controlling the real power flow, it requires separate DC sources as input. To manage these DC sources it becomes difficult as the possibility of a short circuit at the input side. Thereby, the cascaded multilevel inverters have limited applications.

This paper presents a new topology with single DC source and high frequency cascaded transformer to obtain the high output voltage from less input source. The proposed topology has a significance that directly three phase output voltage is obtained from the single leg only. The proposed topology is applicable to Battery storage systems [11] and alternative energy sources to the power grid. The switches in the multilevel inverter are controlled by using the Phase-Shift carrier based PWM modulation technique. By using this technique, harmonics can be reduced and gets the quality output power. Simulation and comparison can be done using the MATLAB/SIMULINK to verify the performance of the proposed topology and other topologies for 11-level.

2. MULTILEVEL INVERTERS WITH SINGLE DC SOURCE

The cascaded multilevel inverters play an important role in medium and high voltage applications as it requires fewer components compared to other topologies. In CHBMLI, increasing the levels increases the DC sources as each H-Bridge needs separate DC sources for each phase and availability of occurring short circuit at the input side. In some applications such as batteries in electric vehicles needs [12] an only single source to reduce the size and cost of the inverter and high-frequency transformers are used for easy isolation. To overcome the disadvantages of cascaded H-Bridge MLI, new families of topologies have been designed with single DC source and high frequency cascaded transformers.

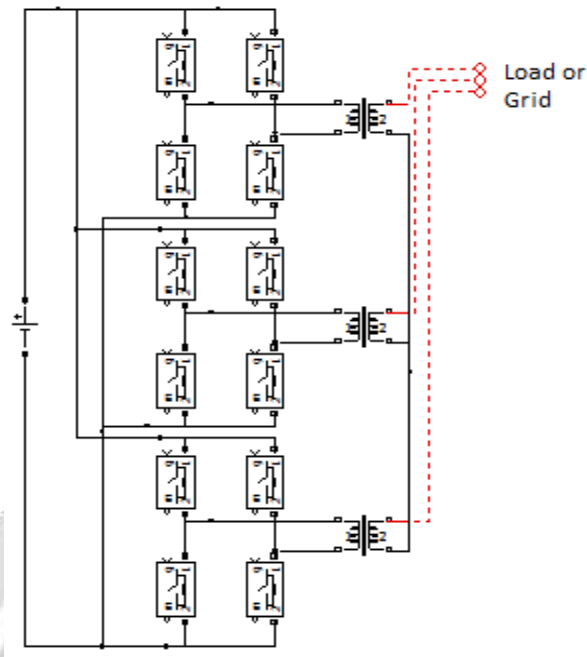

Fig: 2. Topology of H-Bridge cascaded transformer (HBCT) multilevel inverter

Some topologies with Single DC source are (1) H-Bridge Cascaded Transformer (HBCT) Multilevel inverter [16] (2) Combined H-Bridge cascaded transformer (CHBCT) multilevel inverter [14]. (3) Asymmetric Cascaded multilevel inverter. [13] (4) Sub multilevel inverter [15]. For comparison to the proposed topology the HBCT multilevel inverter has shown in the below fig: 3. The HBCT multilevel inverter consists of single DC source and cascaded transformers to obtain the output voltage. The output voltage is increased by increasing the cascaded transformers but not the H-Bridge modules. The transformers are used for easy electrical isolation.

In the HBCT multilevel inverter, the output voltage is evaluated by connecting the primary terminals of the transformers to H-Bridge modules and secondary terminals are connected to the load. The output voltage of 3-level three phase HBCT multilevel inverter is $+V_{dc}$, 0 and $-V_{dc}$. The output voltage is the product of turn's ratio of the transformer and input DC source. The turn's ratio depends upon the type of inverter, if the inverter is symmetric then turn's ratio is one and the inverter is non-symmetric then the turn's ratio depends on the ratio of secondary terminals to the primary terminals.

The number of levels is given by the formula

$$m = 2n + 1 \quad (1)$$

The output voltage is given by the formula

$$V_0 = \sum_{n=1}^n V_n \quad (2)$$

Where n is the number of cascaded transformers and m is the number of levels.

3. PROPOSED VOLTAGE SOURCE CASCADED TRANSFORMER (VSCT) MULTILEVEL INVERTER

The proposed topology uses Voltage source inverters or Six-Switch inverters and high frequency cascaded transformers to produce the three-phase output voltage from the single leg. The proposed topology has Single DC source and eliminates the disadvantages of cascaded H-Bridge multilevel inverters and gives the high output voltage from a lower input voltage. In HBCT multilevel inverter single phase H-Bridge modules are used as shown in the Fig: 2, where in the proposed topology uses Six-Switch inverters as the H-Bridge cells as shown in the figure: 3. The transformers in this topology are used for easy electrical isolation and the leakage reactance in the windings helps to filter the harmonics [17].

The proposed topology has voltage source inverters and complimentary inverter other to provide the positive and negative voltages. The voltage Source inverter consists of six switches to produce the two-level output voltage. For three level three phase output voltage, two voltage source inverters are connected to the single DC source. The primary terminals of the transformers are connected to the voltage source inverters and secondary terminals are connected to the load or power grid to evaluate the output voltage $+V_{dc}$, 0 , $-V_{dc}$. The transformers are used to produce the output voltage from the single DC source and also helps to filter the harmonics. The number of levels is increased by increasing the cascaded transformers and is given by the Eqn:1. The output voltage changes from $+nKV_{dc}$ to $-nKV_{dc}$, where n is the number of cascaded transformers, K is the turn's ratio of the transformer and V_{dc} is the input DC source. The output phase voltage is given by Eqn: 2

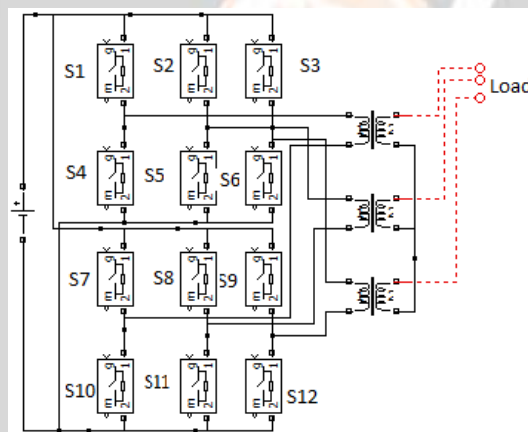

Fig. 3. Basic cell of the proposed topology for three phase three level VSCT multilevel inverter

The two voltage source inverters are controlled by using the most popular and well known PWM technique i.e., Phase-Shift carrier based PWM modulation technique [1]. In phase shift carrier based PWM technique, the pulses are generated by comparing the reference wave with the carrier waves. A Number of carrier waves is $(m-1)/2$, and each carrier wave is shifted by angle $\theta = \frac{360^\circ}{(m-1)}$. The complimentary inverter block is having the same frequency and same magnitude, but 180° phase shift to the inverter block. For example, phase consists of four switches i.e., S1, S4, S7 & S10. S1 & S10 are ON at a time to produce $+V_{dc}$ & 0 and S4 & S7 are ON at a time to produce $-V_{dc}$ & 0 .

The proposed 11-level VSCT multilevel inverter has 10 inverter blocks i.e., five Voltage source inverters and five complimentary voltage source inverters as shown in figure: 4. The complimentary inverter which is next to the six-switch inverter are used to connect the four single phase transformers. The proposed compact VSCT multilevel inverter is shown in fig: 5 uses less number of components as it reduces 36% of a total number of switches. To reduce the number of switches each complimentary inverter is removed from the each basic cell of the cascaded blocks except one complimentary block at one stage is to be placed in order to provide the complimentary path for getting the output voltage and also remove the last transformer of the cascaded transformers if electric isolation is not needed and turn's ratio is small. The proposed compact VSCT uses only 6 inverter blocks for 11-level inverter.

The pulses are generated by comparing the three modulating waves at the fundamental frequency to the carrier waves.

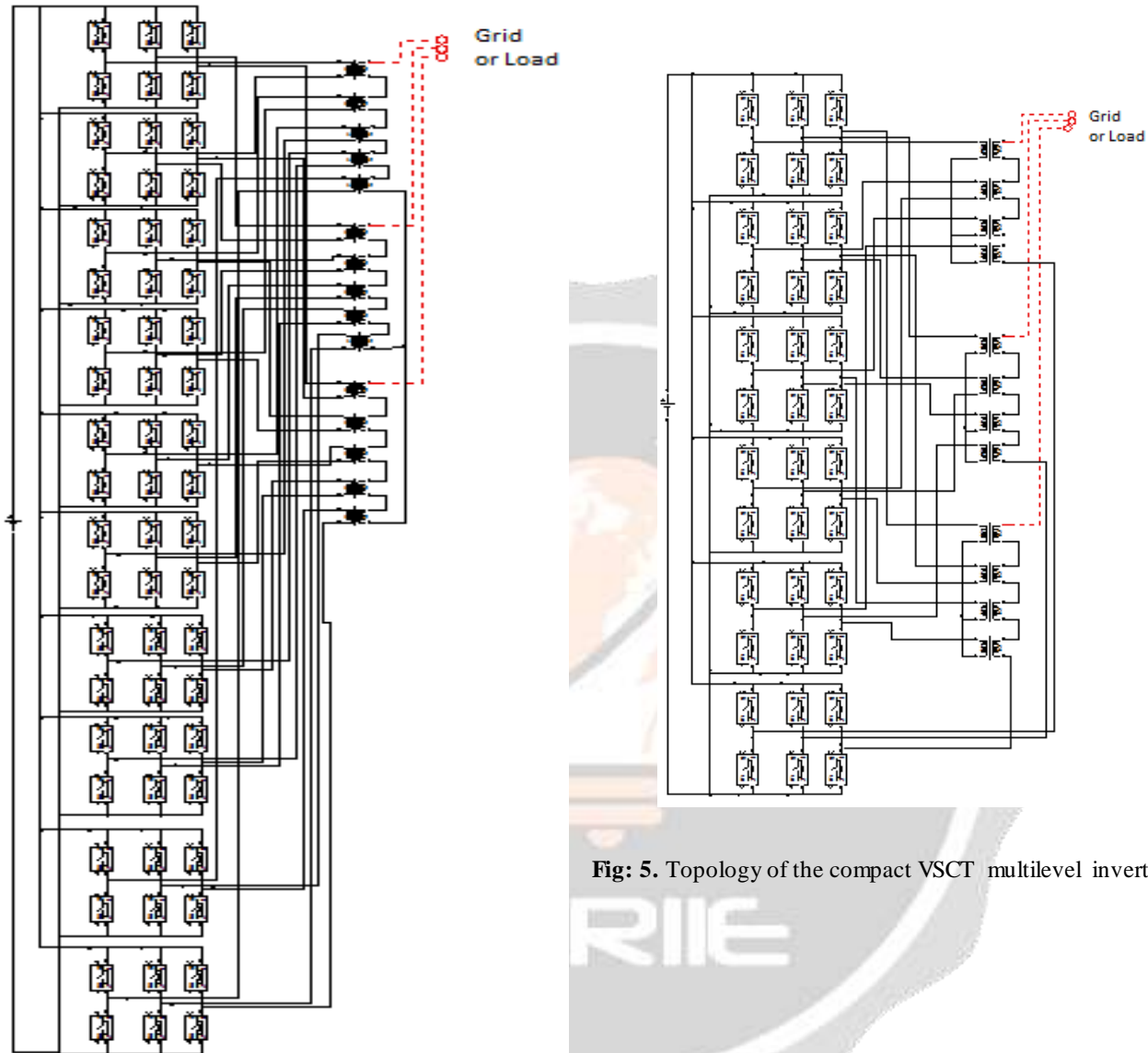

Fig: 4. Topology of initial proposed VSCT Multilevel inverter

The inverter blocks are controlled by Phase shift technique and the carrier wave has a phase shift is given by

$$\theta = \frac{i \times 360^\circ}{(m-1)}$$

Where ‘i’ is the cascaded stage number and the complimentary block have the same carrier waves of the inverter, but modulating waves are shifted by 180°.

4. SIMULATION AND COMPARISON RESULTS

In multilevel inverters as the number of level increases to get the quality power, the components also increase then the cost and size of the inverter increases where the proposed topology uses fewer components. The

conventional multilevel inverter uses 60 switches, but the proposed inverter uses only 36 switches. Simulation can be done in MATLAB/SIMULINK to verify the performance of the proposed Voltage Source Cascaded Transformer multilevel inverter and conventional H-Bridge cascaded transformer multilevel inverter and the simulation diagram of compact proposed VSCT multilevel inverter where the turn's ratio is same as shown in the fig: 6.

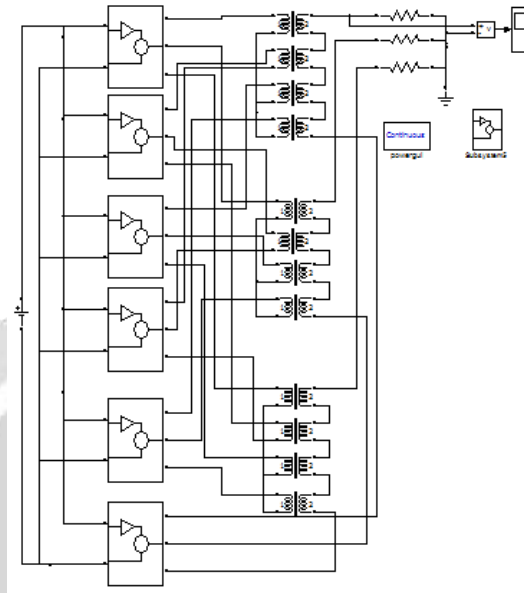

Fig: 6. Simulation diagram of proposed compact VSCT multilevel inverter

TABLE-1

COMPARISON OF COMPONENTS IN THE PROPOSED AND OTHER TOPOLOGIES FOR THREE PHASE NINE-LEVEL

	CHB multilevel inverter	HBCT multilevel inverter	VSCT multilevel inverter
Input DC sources	15	1	1
Switches	60	60	36
Cascaded Transformers	0	5	4

Figure: 7 &8 shows the output voltage waveforms and the corresponding THD for the both conventional HBCT multilevel inverter and the proposed inverter. The proposed inverter has low harmonic distortion compared to conventional and less number of components are used. In the proposed topology to achieve the high output voltage, high frequency transformers turn's ratio is unity and carrier frequency is high. Inductance and capacitance are used to filter the harmonics.

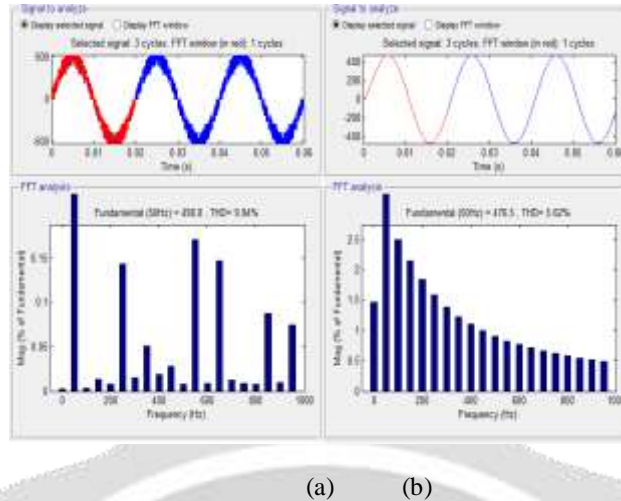

Fig: 7. Output waveforms of the HBCT multilevel inverter (a) without filter (b) with filter

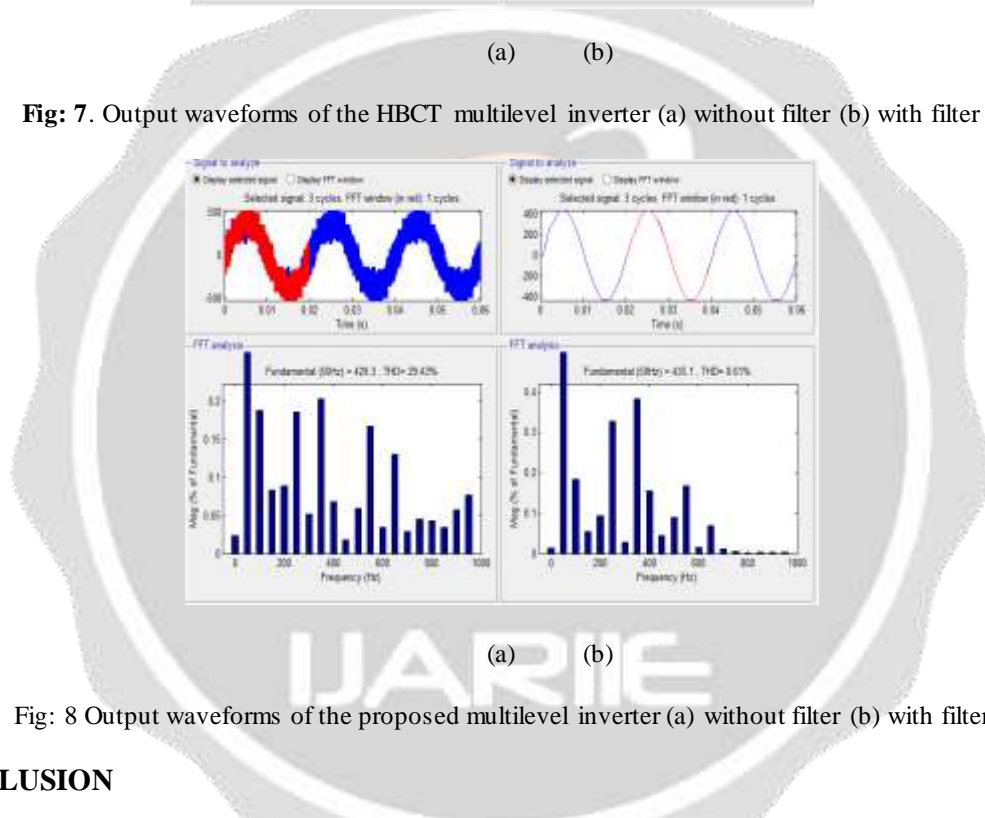

Fig: 8 Output waveforms of the proposed multilevel inverter (a) without filter (b) with filter

5. CONCLUSION

This paper presents a new topology of multilevel inverter with single DC source and three high frequency cascaded transformer blocks to produce the high output voltage from low input voltage. The proposed topology consists of voltage source inverters and three cascaded transformers blocks for three phase supply directly from the single leg. The proposed topology eliminates the limitations of conventional H-Bridge multilevel inverter and is applicable to high power and high voltage applications such as batteries and renewable energy storage devices. The simulation results can be studied in MATLAB and it is verified that, the proposed topology gives the better performance over to conventional topology. The proposed topology reduces the harmonics i.e. lower order harmonics and the higher order harmonics can be easily filtered by using filters.

6. REFERENCES

- [1] J. Rodriguez, J-S. Lai, and F.Z. Peng, "Multilevel Inverters: A Survey of Topologies, Controls, and Applications," *IEEE Trans. Ind. Electronic*, vol.49, no.4, Aug.2002.
- [2] L. Tolbert, F.-Z. Peng, and T. Habetler, "Multilevel converters for large electric drives," *IEEE Trans. Ind. Applicat.*, vol. 35, pp. 36–44, Jan./Feb. 1999.
- [3] F. Z. Peng and J. S. Lai, "Multilevel cascade voltage-source inverter with separate DC sources," U.S. Patent 5 642 275, June 24, 1997.
- [4] J. S. Lai and F. Z. Peng, "Multilevel converters—A new breed of power converters," *IEEE Trans. Ind. Applicat.*, vol. 32, pp. 509–517, May/June 1996.
- [5] A. Nabae, I. Takahashi, and H. Akagi, "A new neutral-point clamped PWM inverter," *IEEE Trans. Ind. Applicat.*, vol. IA-17, pp. 518–523, Sept./Oct. 1981.
- [6] T. A. Meynard and H. Foch, "Multi-level choppers for high voltage applications," *Eur. Power Electron. Drives J.*, vol. 2, no. 1, p. 41, Mar. 1992.
- [7] C. Hochgraf, R. Lasseter, D. Divan, and T. A. Lipo, "Comparison of multilevel inverters for static var compensation," in *Conf. Rec. IEEE-IAS Annu. Meeting*, Oct. 1994, pp. 921–928.
- [8] P. Hammond, "A new approach to enhance power quality for medium voltage ac drives," *IEEE Trans. Ind. Applicat.*, vol. 33, pp. 202–208, Jan./Feb. 1997.
- [9] R. H. Baker and L. H. Bannister, "Electric power converter," U.S. Patent 3 867 643, Feb. 1975.
- [10] E. Cengeli, S. U. Sulistijo, B. O. Woom, P. Enjeti, R. Teodorescu, and F. Blaabjerge, "A new medium voltage PWM inverter topology for adjustable speed drives," in *Conf. Rec. IEEE-IAS Annu. Meeting*, St. Louis, MO, Oct. 1998, pp. 1416–1423.
- [11] Energy Storage Research and Development 2009 Progress Report, <http://www.leere.energy.gov/vehiclesandfuels/resources/fcvtreports.htm>.
- [12] K. Tsuchiyama, N. Hoshi, I. Haruna, "Isolated AC-DC Converter using Voltage Doubler Rectifier with Half-Bridge Inverter," *IEEE Vehicle Power and Propulsion Conference*, Oct. 9-12, 2012, Seoul, Korea
- [13] Javier Pereda, and I. Dixon, "High-frequency link: a solution for using only one DC source in asymmetric cascaded multilevel inverters" *IEEE Trans. Ind. Electronics*, vol. 58, no. 9, Sep. 2011.
- [14] H. k. jahan, M. R. banaei, and S. T. Mobaraki, "Combined H-bridge cells cascaded transfontners multilevel inverter" *PEDSTC*, Feb. 5-6, 2014.
- [15] . R. Banaei and E. Salary, "A new family of cascaded transformer six switches sub-multilevel inverter with several advantages," *J ElectrEngTechnol*, vol. 8, no.5, 2013.
- [16] Y. Suresh, A. K. Panda, and Matada Mahesh, "An improved performance of cascaded multilevel inverter with single DC source by employing three-phase transformers," *2010 9th International Power & Energy Conference (IPEC 2010)*, pp. 1088-1093, 2010.
- [17] Z.Alaas and C.Wang, "A New Isolated Multilevel Inverter Based on Cascaded Three- Phasse Converter Blocks," *National Science Foundation of USA under Grant ECCS-1202133*.

BIOGRAPHIES

G.Kumaraswamy is born in 1983 in India. He is graduated from JNTU University in 2005 and pursued Post graduation from the same university. He is Research Scholar at KL University, Vijayawada. He is currently working as an Assistant professor in the department of electrical and electronics engineering R.G.M college of engineering and technology, Nandyal, Andhra Pradesh, India. He has eleven years of teaching experience. He has attended several National workshops. His main areas of research include Induction motor drives, Electrical machines FACTS and Harmonic reduction in power converters.



R.Pradeepa is born in 1993 in India. She is graduated from G.P.C.E.T, Kurnool in 2014. Presently she is doing Post graduation in Power Electronics and Electrical Drives Specialization at R.G.M college of engineering and technology, Nandyal, Andhra Pradesh, India. Her main areas of interest include Power Electronics & Converters, Power Electronic Drives and Electrical Machines.

