

A Novel Approach to Improve WSN by using advanced BIOSARP and SRTLTD Protocol

Sayali Thorat¹, Prof.M.K.Night²

¹ ME (student), Computer Engineering, KJCOEMR, Maharashtra, India

² Professor, Computer Engineering, KJCOEMR, Maharashtra, India

ABSTRACT

A wireless sensor network which plays crucial role in wireless communication. The intensification of wireless sensor network increases day by day which is used in every field like military, government etc. the battery is one of the main source of the energy for the sensor nodes. The difficulty arises in Wireless Sensor Network (WSN) when the distance among the nodes increases and obviously as distance increases numerous hops will necessitate for data forwarding from source to destination or at particular location. WSN routing protocol defined as secure real-time load distribution (SRTLTD) uses broadcast packets to perform neighbor discovery and calculation at every hop while transferring data packets. Thus, it has high energy consumption. The proposed novel biological inspired self-organized secure autonomous routing protocol (BIOSARP) enhances SRTLTD with an autonomous routing mechanism. The proposed BIOSARP has been designed to reduce the broadcast and packet overhead in order to minimize the delay, packet loss, and power consumption in the WSN.

Keyword : - Wireless Sensor Network, Ant Colony System, Optimization, SRTLTD, BIOSARP

1. INTRODUCTION-1

In telecommunication field, wireless communication plays an important role. Wireless sensor network is key factor of wireless communication, it combines sensing, computation and communication into a small device.

1.1 Wireless Sensor Network -1

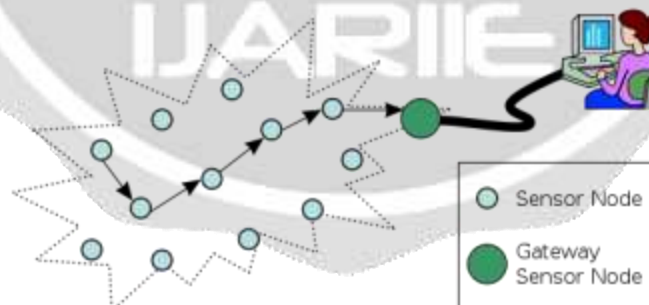

Fig-1 Wireless sensor network

Fig. 1 demonstrate the WSN, where tiny sensor nodes are distributed and they work as a monitor to monitoring physical and environmental conditions like sound, pressure, temperature, humidity etc.

Important factor in WSN is Sensor node, Sensor node is nothing but small device which is capable of detecting physical changes. It consists of 4 factors such as sensing unit, processing unit, communication unit and power unit. Fig.2 demonstrate the internal structure of sensor node –

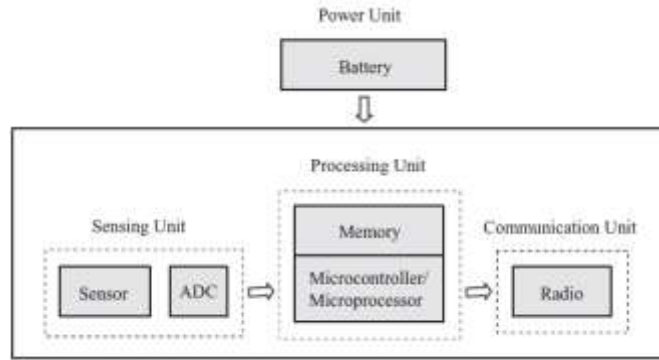

Fig-2 Sensor Node structure

WSN mainly used in applications like – Environmental monitoring, Military applications, Health care applications and Home Intelligence applications etc.

WSN architecture is classify into 2 types –

1. Flat Architecture – In this type each node plays the same role in performing sensing task and all sensor nodes are peers.
2. Hierarchical Architecture – sensor nodes are organized clusters, where the cluster members send their data to the sink.

Network Design Challenges –

- Limited Energy Capacity
- Limited Hardware Resources
- Massive and Random Deployment
- Dynamic and Unreliable Environment
- Diverse Applications

In many WSN applications, the sensor nodes are worked on battery but they have some drawbacks like difficult to recharge or change the batteries. Prolonging network lifetime is another big critical issue. Energy efficiency is also big challenge for WSN.

In order to extend the network lifetime of WSN, extra sensor nodes needs to distribute to allow a certain fraction of the nodes to sleep from time to time. Ant Colony Optimization is one of the important concepts for improving WSN performance.

1.2 Ant Colony Optimization -2

Ant system first introduced by Marco Dorigo in 1992. It is originally applied for Traveling Salesman Problem. Ant Colony Optimization (ACO) is nothing but the artificial systems which is inspired from the behavior of real ant colonies such as pheromone communication between ants regarding a good path between the colony and a food source in an environment. This mechanism is called stigmergy. This ACO is used to solve discrete optimization problems such as WSN challenges. It consists of Swarm Intelligence, Metaheuristics and Computational Intelligence. A multi-path data transfer is also accomplished to provide reliable network operations, while considering the energy levels of the nodes.

In the ACO based approach, each ant tries to find a path in the network, providing minimum cost. Ants are launched from a source node s and move through neighbour repeater nodes r_i , and reach a final destination node

(sink) d. Whenever, a node has data to be transferred to the destination which is described as a base or base station, launching of the ants is performed.

Probabilistic decision rule:

$$P_k(r, s) = \begin{cases} \frac{[\tau(r, s)]^\alpha \cdot [\eta(r, s)]^\beta}{\sum_{r \in R_s} [\tau(r, s)]^\alpha \cdot [\eta(r, s)]^\beta} & \text{if } k \notin \text{tabu}^r \\ 0 & \end{cases}$$

Where,

- $\tau(r, s)$ is the pheromone value,
- $\eta(r, s)$ is the value of the heuristic related to energy,
- R_s is the receiver nodes.
- α and β are two parameters that control the relative weight of the pheromone trail and heuristic value.

ACO algorithm is agent based [12] as it consist 4 main concepts - forward ant (FA), backward ant (BA), search ant (SA) and data ant (DA)

[C] Routing Protocol

SRTLTD evaluated on a true WSN test bed. It is based on geodirectional- basically it is localized routing protocol which generates one hop optimum node choices. The optimum call depends on the end-to-end delay, packet reception rate (PRR), and remaining battery power. SRTLTD reduces the energy consumption by minimizing the transmitter power level to broadcast with a spread. It helps in handling WSN issues like broadcasting from hop causes ultra-high power consumption, extra delay, and packet loss, and therefore reduces the info turnout within the WSN. It also provides security to WSN.

BIOSARP i.e. Biological-inspired Self-Organized Secure Autonomous Routing Protocol is another protocol which also helps in WSN for tackling the issues. It utilizes ANT Colony Optimization (ACO) for finding optimum route in WSN is presented in [12-14]. BIOlogical Inspired Self-organized Secure Autonomous Routing Protocol (BIOSARP) is introduced to handle self-security management module. BIOSARP is mainly based on the behavior of human immune system (HIS). As HIS provides the complete security and protection to human body BIOSARP provide security to WSN. The major function of HIS is to identify the anomalies by differentiating between self and non-self-entities. The HIS security is used in the computer technology which also known as artificial immune system (AIS). Implementation of AIS algorithms in WSN is very complex and impractical, but BIOSARP this complexity factor is handled by BIOSARP.

BIOSARP is basically based on Ant colony optimization (ACO) with ACO BIOSARP give the better performance and can be practically implemented within WSN applications for structural and environmental monitoring or for battlefield surveillance.[1]

2. LITERATURE REVIEW -2

There are different protocols and techniques are proposed for improving WSN functionality, most of them are based on ant optimization techniques. Kashif Saleem et all introduces in [1] a biological inspired self-organized secure autonomous routing protocol (BIOSARP). This protocol is based on ANT Colony System (ACS) for an optimal route decision, enhanced with artificial Immune System (HIS) inspired autonomous security mechanism. Saleem, K. et all enhanced BIOSARP protocol with SRTLTD in [3], an autonomous routing mechanism. Here they used improved ant colony optimization (IACO). By using IACO they enhanced BIOSARP functionality by reducing the broadcast and packet overhead in order to minimize the delay, packet loss, and power consumption in the WSN. Kashif Saleem et all designed a cross layer design based self-optimized (ACO) routing protocol for WSN and the results are presented in [4]. Link quality, energy level and velocity parameters are used to discover an optimal route. The signal strength, remaining power and timestamp metrics are trade in from physical layer to network layer. K.Saleem presented in [5] the design and result of ant based autonomous routing algorithm for the sensor networks their mechanism enhanced sensor network requirements, including energy consumption, success

rate and time. Z. Cong et al introduced the Ant Colony optimization technique in their paper [7], they explained an innovative ant-based optimization way which allows guiding during routing decision. Mina Jafari et al implemented [9] a mechanism for Wireless sensor network routing which can be effective for the criteria of route length, end-to-end delay and network node energy for the quality of mechanism service. They proposed a method, which uses ant colony-based routing algorithm and local enquiry to find optimal routes. Bhaskaran, K et al propose [14] an ACO-based algorithm to solve the dynamic any cast routing and wavelength assignment (RWA) problem in wavelength-routed WDM networks. Fangyu Chen et al developed a new routing algorithm based on Ant Colony Optimization (ACO) for two order pickers (A-TOP) with congestion consideration.

3. SYSTEM MODEL AND ITS DESIGN GOALS -3

3.1 System Model

Fig. 3 demonstrates the system model of WSN, which has several sub modules as –

- Network reading
- Identification of Route
- Calculation of Pheromone and Throughput
- Energy & value Estimation
- Security (Encryption & cryptography)
- Best Route Identification & knowledge Transfer

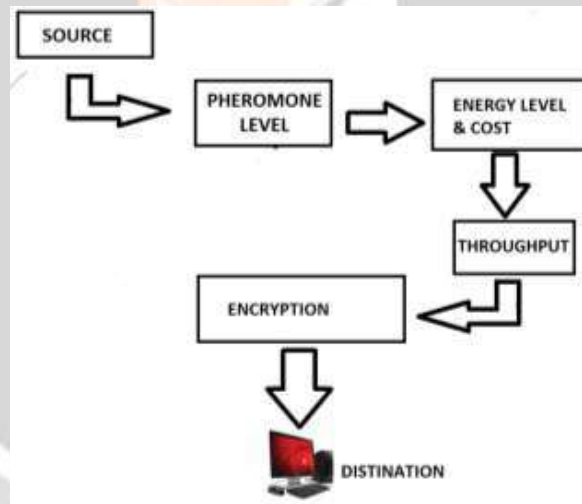

Fig-3 System Model

3.2 Design Goals

Proposed system should achieve below mentioned design objectives:

- Low node cost
- Low Power Consumption
- Self-configurability
- Communication Channel Utilization
- Data Security

4. PROPOSED SYSTEM

Architecture of proposed WSN system is shown in Fig.4.

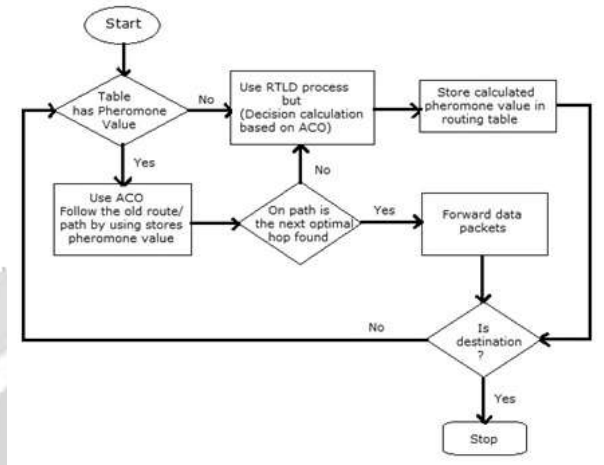

Fig-4 System Architecture

In WSN there are several nodes available, before sending any packets we need to finalized the network, in this case node sent request to server and find the required response from server. Then by using ACO (Ant Colony Optimization) technique route will get finalized. With help of routing protocol data packets are broadcasted within the decided network. With the help of cryptography security is provided to the packets, packets are in encryption format and node has its key to decrypt them after receiving. Proposed system then help to calculate the energy consumption at each node, it also calculates end-to-end delay.

5.RESULT

5.1 Graphical comparison of BIOSARP and Normal Routing.

All nodes are deployed in to a wireless network shown in fig.5. There is no any communication between node.

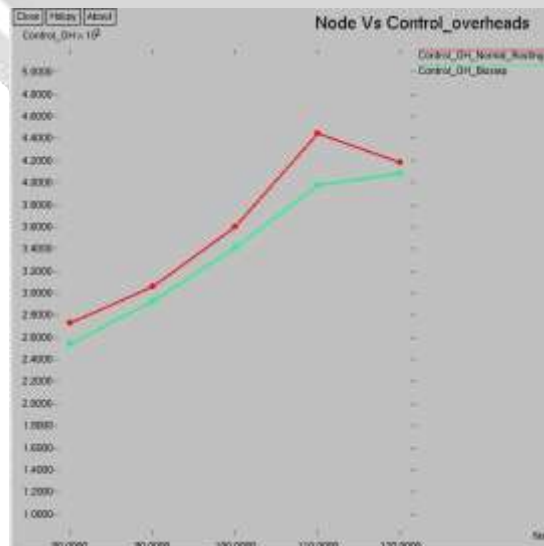
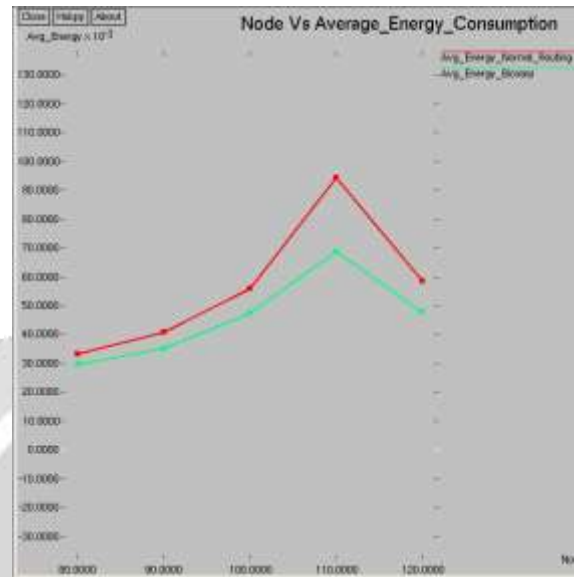

Fig-5 Node Vs Packet Overhead

In above Fig.5 contains the communication structure of sensor nodes in which signal is pass between different sensor nodes. Above figure contain 100 sensor nodes which are communicate with each other.

**Fig-6** Energy Consumption

In above Fig.6 contains proposed work consist of sensor nodes who has unique ID as well x, y position in network. This nodes are communicating with each other different signals data are transfer between them.

4. CONCLUSIONS AND FUTURE SCOPE

A wireless sensor network (WSN) depends on miniaturized wireless sensor nodes that are deployed to monitor physical phenomena by communicating with each other with limited resources. The energy is very important parameter to increase the life time of WSN. In this paper presents, the biological inspired self-organized secure autonomous routing protocol (BIOSARP) which enhances SRTLTD with an autonomous routing mechanism. The Ant colony optimization (ACO) techniques are used in BIOSARP which give the optimized solution for communication in WSN. The Security can add extra benefits in the system. The energy utilization can be the crucial part for Future advancement of topic.

5. REFERENCES

- [1] Kashif Saleem, Norsheila Fisal, Member, IEEE, and Jalal Al-Muhtadi, Member, IEEE "Empirical Studies of Bio-Inspired Self-Organized Secure Autonomous Routing Protocol" IEEE SENSORS JOURNAL, VOL. 14, NO. 7, JULY 2014
- [2] S. Balasubramaniam, et al., "Biologically Inspired Self-Governance and Self-Organisation for Autonomic Networks," presented at the Proceedings of the 1st international conference on Bio inspired models of network, information and computing systems, Cavalese, Italy, 2006
- [3] Kashif Saleem, Norsheila Fisal, Sharifah Hafizah Faculty of Electrical Engineering Universiti Teknologi Malaysia 81310-Skudai, Malaysi "BIOSARP: Biological Inspired Self-Organized Secure Autonomous Routing Protocol for Wireless Sensor Network". Recent Researches in Applied Informatics and Remote Sensing.
- [4] K. Saleem, *et al.*, "Ant based Self-organized Routing Protocol for Wireless Sensor Networks," International Journal of Communication Networks and Information Security (*IJCNIS*), vol. Vol. 2, pp. 42-46, August 2009.

- [5] K. Saleem, *et al.*, "Ant Colony Inspired Self- Optimized Routing Protocol based on Cross Layer Architecture for Wireless Sensor Networks," WSEAS TRANSACTIONS on COMMUNICATIONS (WTOC), vol. 9, pp. 669-678, 2010.
- [6] K. Saleem, *et al.*, "Cross Layer based Biological Inspired Self-Organized Routing Protocol for Wireless Sensor Network," presented at the TENCON 2009, Singapore, 2009
- [7] G. Chen, *et al.*, "An improved ant-based routing protocol in Wireless Sensor Networks," in Collaborative Computing: International Conference on Networking, Applications and Worksharing, 2006. CollaborateCom 2006., New York, NY, 2006, pp. 1-7.
- [8] Dorigo, M., &Stützle, T. (2010). Ant colony optimization: overview and recent advances. In Handbook of metaheuristics (pp. 227-263).Springer.
- [9] Jafari, M., &Khotanlou, H. (2013). A Routing Algorithm Based an Ant Colony, Local Search and Fuzzy Inference to Improve Energy Consumption in Wireless Sensor Networks. International Journal of Electrical and Computer Engineering (IJECE), 3(5), 640-650
- [10] Chen, F., Wang, H., Qi, C., &Xie, Y. (2013). An ant colony optimization routing algorithm for two order pickers with congestion consideration. Computers & Industrial Engineering, 66(1), 77-85.
- [11] based routing for mobile ad-hoc networks towards improved quality of services. Journal of Emerging Trends in Computing and Information Sciences, 3(1), 10-14.
- [12] Wei, D., Jin, Y., Vural, S., Moessner, K., &Tafazolli, R. (2011). An energy-efficient clustering solution for wireless sensor networks. Wireless Communications, IEEE Transactions on, 10(11), 3973-3983.
- [13] Ehsan, S., &Hamdaoui, B. (2012). A survey on energy-efficient routing techniques with QoS assurances for wireless multimedia sensor networks. Communications Surveys & Tutorials, IEEE, 14(2), 265-278.

