

A REVIEW ON EXPERIMENTAL ANALYSIS AND OPTIMIZATION OF MDF CUTTING USING LASER AND AWJM

Vaibhav Javale

Assistant Professor, Swarnim Institute of Technology.

Abstract

Fiber Laser Cutting is non-conventional machining process in which laser is generated and highly intense laser impinge onto the surface of the material to cut. Fiber laser cutting is newly developed process which is modified from simple laser cutting. Due to using fiber optics there is less power loss as compared to the laser cutting. Carbon Dioxide gases are used as the assist gas. This project work focuses on finding out the optimum parameters in CO₂ laser cutting for Medium Density Fiber board. Input process parameters that are taken into consideration are operating power, cutting speed and focal point. The effect of input parameters on performance parameters such as surface roughness, kerf width will be experimentally noted and optimization of parameters is done with the help of Genetic Algorithm (GA) for CO₂ as the assist gas. Response surface methodology has been used for DOE with Central Composite runs giving 20 runs for CO₂ as the assist gas.

Keywords – LASER, Cutting, Parametric Optimization, AWJM, comparison

I. INTRODUCTION

Laser cutting is a technology that uses a laser to cut materials, and is typically used for industrial manufacturing applications, but is also starting to be used by schools, small businesses, and hobbyists. Laser cutting works by directing the output of a high-power laser most commonly through optics. The laser optics and CNC (computer numerical control) are used to direct the material or the laser beam generated. A typical commercial laser for cutting materials would involve a motion control system to follow a CNC or G-code of the pattern to be cut onto the material. The focused laser beam is directed at the material, which then either melts, burns, vaporizes away, or is blown away by a jet of gas, leaving an edge with a high-quality surface finish. Industrial laser cutters are used to cut flat-sheet material as well as structural and piping materials.

A. WORKING PRINCIPLE OF LASER

There are many different methods in cutting using lasers, with different types used to cut different material. Some of the methods are vaporization, melt and blow, melt blow and burn, thermal stress cracking, scribing, cold cutting and burning stabilized laser cutting.

Vaporization cutting

In vaporization cutting the focused beam heats the surface of the material to boiling point and generates a keyhole. The keyhole leads to a sudden increase in absorptivity quickly deepening the hole. As the hole deepens and the material boils, vapor generated erodes the molten walls blowing eject out and further enlarging the hole. Non melting material such as wood, carbon and thermoset plastics are usually cut by this method.

Melt and blow

Melt and blow or fusion cutting uses high-pressure gas to blow molten material from the cutting area, greatly decreasing the power requirement. First the material is heated to melting point then a gas jet blows the molten material out of the kerf avoiding the need to raise the temperature of the material any further. Materials cut with this process are usually metals.

Thermal stress cracking

Brittle materials are particularly sensitive to thermal fracture, a feature exploited in thermal stress cracking. A beam is focused on the surface causing localized heating and thermal expansion. This results in a crack that can then be guided by moving the beam.

Stealth dicing of silicon wafers

The separation of microelectronic chips as prepared in semiconductor device fabrication from silicon wafers may be performed by the so-called stealth dicing process, which operates with a pulsed Nd:YAG laser, the wavelength of which (1064 nm) is well adapted to the electronic band gap of silicon (1.11 eV or 1117 nm).

Reactive cutting

Also called "burning stabilized laser gas is cutting", "flame cutting". Reactive cutting is like oxygen torch cutting but with a laser beam as the ignition source. Mostly used for cutting carbon steel in thicknesses over 1 mm. This process can be used to cut very thick steel plates with relatively little laser power

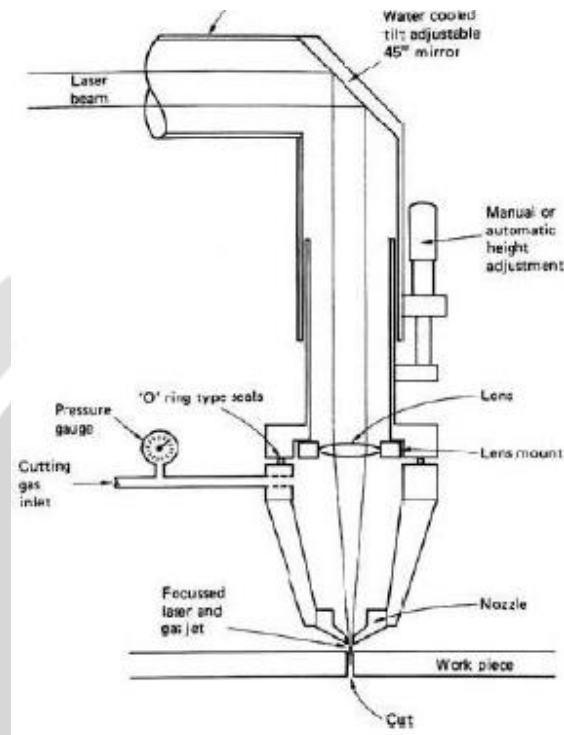

Figure 1: Laser cutting Process Setup

B. LASER AND AWJM EFFECTING PARAMETERS:

The process parameters that can affect the quality of machining or cutting through laser cutting

The major parameters are as follows:

Laser Power, Cutting Speed and Focal length with two parametric levels

A comparison is done with AWJM technique and for that selected parameters are:

Abrasive mass flow, feed speed, stand off distance

II. LITERATURE REVIEW

K.C.P. Lum et al.[1], investigated into the laser processing of medium-density fibreboard (MDF). Part 1 reports on the determination of process parameter settings for the effective cutting of MDF by CO₂ laser, using an established experimental methodology developed to study the interrelationship between and effects of varying laser set-up parameters. Results are presented for both continuous wave (CW) and pulse mode (PM) cutting, and the associated cut quality effects have been commented on. Experimental results for the laser cutting of MDF in both CW and PM have been presented. The data for CW cutting appears to be in broad agreement with that obtained by Powell for a 1 kW laser. The results given here were used as a basis for the next stage of work as reported in Part 2 of this paper. Part 1 of the paper has also shown that narrow kerf widths are achievable for lasercut MDF, particularly for PM cutting. Striation patterning, although masked by external charring, is evident, but this is of little significance to the overall quality of cut as evidenced by the low Ra values obtained. Burnout is also minimal, even for angular profile cuts of small internal angle

H. A. Eltawahni et al. [2] showed Researched that Laser cutting of medium density fibreboard (MDF) is a complicated process and the selection of the process parameters combinations is essential to get the highest quality of the cut section. This paper presents laser cutting of MDF based on design of experiments (DOE). CO₂ laser was used to cut three thicknesses 4, 6 and 9 mm of MDF panels. The process factors investigated are: laser power, cutting speed, air pressure and focal point position. They have also investigated cutting quality was evaluated by measuring, upper kerf width, lower kerf width, ratio between the upper kerf width to the lower kerf width, cut section roughness and the operating cost. The average upper kerf width decreases as the focal point position, cutting speed and air pressure increase, and it increases as the laser power increases. The focal point position has the main role in affecting the upper kerf. The average lower kerf width decreases as the cutting speed increases and it increases as the laser power increases, it changes slightly as the focal point position increases. The laser power and cutting speed have the main effect on the lower kerf width.

Snežana Radonjić et al. [3] has researched about Process Parameters of Laser Cutting of Stainless Steel 314 of 10 mm Sheet. Four Process Parameters for this Research was Selected which are the focal position, Laser power, Gas pressure, Nozzle distance. Adequate accuracy of the quality and shape of the cut has been reached. Therefore, the obtained parameters are reliable and are further used in the production process. Focus position too high. Situation: Very sharp rough edge (requires mechanical removal) on the underside of the sheet. A good cut with irregularities from the middle of the cut downwards. Solution: Set the position of the focus deeper. Increase gas pressure. The higher the gas pressure, the better the removal of molten material. Focus position too low. Situation: Small beads forming on the underside of the sheet. Rough surface of the cut from the middle of the sheet downwards. Solution: Set a greater numeric value of the focus position. Reduce feed rate.

A.G. Malikov et al. [4] Reactive laser cutting of mild steel is wide spread in practice. High processing speed is the feature of the laser cutting, with high quality of laser cut is of interest. The laser cut quality is characterized by dross attachment, surface roughness, the width of heat affected zone, side walls perpendicularity, cut width. In spite of large amount of theoretical and experimental investigations, the completed and explicit picture of physical processes, responsible for cut quality, is not exist at present time. Especially it is right for thick sheet region. Laser cutting models for thick section region are developed inadequately. The interrelationship between optimum cutting parameters is not substantiated by these models in most cases. A lot of models are based on the substantial simplifications. The experimental investigations dealing with the conditions of getting of high quality cut are made in majority for thin sheets (no more of 10 mm). Also laser cutting data base is concerned of thin sheets mostly.

Mohamed Hassan Gadallah et al. [5] Laser beam cutting is one important non-traditional machining process. This paper optimizes the parameters of laser beam cutting parameters of stainless steel (316L) considering the effect of input parameters such as power, oxygen pressure, frequency and cutting speed. Statistical design of experiments is carried in three different levels and process responses such as average kerf taper (Ta), surface roughness (Ra) and heat affected zones are measured accordingly. A response surface model is developed as a function of the process parameters. Responses predicted by the models (as per Taguchi's L27OA) are employed to search for an optimal combination to achieve desired process yield. Response Surface Models (RSMs) are developed for mean responses, S/N ratio, and standard deviation of responses. Optimization models are formulated as single objective optimization problem subject to process constraints. Models are formulated based on Analysis of Variance (ANOVA) and optimized using Matlab developed environment. Optimum solutions are compared with Taguchi Methodology results. As such, practicing engineers have means to model, analyze and optimize non-traditional machining processes. Validation experiments are carried to verify the developed models with success.

Mayank Madia et al. [6] laser is uniquely versatile tool for processing a remarkable range of metals, alloys, ceramics, glasses, polymers and composites In manufacturing industries. Fiber laser cutting, because of the narrow beam, small spot size, high intensity, depth of focus and easily absorbed by metal surfaces, present research work focuses on "fiber laser cutting process" out of all commercialized techniques for sheet metal cutting. The current research is based on experiments on cutting covering cutting of 2 mm thick super duplex stainless steel and 1.6 mm thick Titanium alloy using the 1000 watt high power fiber laser machine. The cut qualities were analyzed by measuring the surface roughness and kerf width by varying parameters like laser power, cutting speed and gas pressure. Oxygen assist gas was used for cutting of stainless steel..

III. CONCLUSION

The following points can be concluded from this work within the factors limits:

- The effects of all factors have been established at their different levels.
- The average upper kerf width decreases as the focal point position, cutting speed and air pressure increase, and it increases as the laser power increases. The focal point position has the main role in affecting the upper kerf.

- The average lower kerf width decreases as the cutting speed increases and it increases as the laser power increases, it changes slightly as the focal point position increases.
- The laserpower and cutting speed have the main effect on the lower kerf width.
- The ratio decreases as the focal point position and laser power increase, however, the laserpower effect reduces as the material becomes thicker. Focal point position and the laserpower are the principal factors affecting the ratio.
- The roughness of the cut section decreases as the focal point position and the laser power increase, but the laser power effect reduces when cutting thicker MDF sheets. The roughness increases as the cutting speed and the air pressure increase. All the factors are principally affect the roughness.
- High quality or economical cut sections could be processed using the tabulated optimal setting.

IV. REFERENCES

- [1.] S.L. Ng, K.C.P. Lum, I. Black, "CO₂ laser cutting of MDF 2. Estimation of power distribution", *Optics & Laser Technology* 32 (2000) 77-87, 21 February 2000.
- [2.] H. A. Eltawahni, A. G. Olabi and K. Y. Benyounis, "Investigating the CO₂ laser cutting parameters of MDF wood composite material", *Material Processing Research Centre, School of Mech. & Manu. Eng., Dublin City University, Dublin 9, Ireland.*
- [3.] V.Senthilkumar, M. Bharath, K.Dhanapal, M.Dhinesh Kumaran, R.Gobinath, "Analysis and Optimization of Laser Machining Parameters", *International Journal of Innovative Research in Science, Engineering and Technology*, ISSN (Online): 2319-875, ISSN(Print): 2347-6710, Vol. 5, Special Issue 8, May 2016.
- [4.] V.Senthilkumar, P.Pon Karthick Raja, R.Pravin Raj, S.Raja Periyasamy, S.Sakthidharan, "Experimental Investigation and Analysis of Process Parameters for Laser Cutting Process", *International Journal of Innovative Research in Science, Engineering and Technology*, ISSN (Online): 2319-8753, ISSN (Print): 2347-6710, Vol. 5, Special Issue 8, and May 2016.
- [5.] N.Periyasamy, A.Manigandan, "Parametric Investigation of Process Parameters for Laser Cutting Process", *International Journal of Innovative Research in Science, Engineering and Technology*, ISSN (Online): 2319-8753, ISSN (Print): 2347-6710, Vol. 4, Issue 5, and May 2015.
- [6.] Natasa Naprstkova, Stanislav Dubsky, "Optimization of Setting Parameters of Laser Cutting Machine", *Jan Evangelista Purkyn University in Ústí nad Labem, Czech Republic*, 24.-25.05.2012