

A STAND-ALONE RENEWABLE ENERGY BASED POWER GENERATION USING OPTIMAL CONTROL STRATEGY

M Santhosh¹, B Babu²

¹ student, Dept of EEE, Jyothismathi Institute of Technology and Science, Telangana, INDIA

² Asst. prof, Dept of EEE, Jyothismathi Institute of Technology and Science, Telangana, INDIA

ABSTRACT

This paper presents a flexible control of power generated using a PV power conditioning system with energy storage. The proposed conditioning unit contains a boost converter (BC), a single-phase inverter, and a bidirectional dc/dc converter connected to the PV side of the BC, general load and critical load. The BC regulates the dc-link bus-voltage. The bidirectional dc/dc converter endures battery bank charge/discharge control and PV maximum power point tracking (MPPT). Such architecture guarantees non change in controller configuration when the storage disconnects. Also flow of power from source to loads in the case partial and full irradiation conditions. A system control strategy based on sliding-mode control, battery charge control and trip control ensures a reliable output voltage regulation such as fast dynamic response, small steady-state error, and low total harmonic distortion (THD) under step changes are analyzed. The proposed system is designed using MATLAB software for detailed analysis.

Keyword: - Energy storage, flexible stand-alone, photovoltaic (PV), PV system, sliding-mode control (SMC).

1. INTRODUCTION

Solar energy is considered to be one of the most effective resources, attracting much attention due to its ubiquity and sustainability. Stand-alone photovoltaic system (SPVS) is one of the popular applications in photovoltaic (PV) generation and has highly practical values in off-grid areas. Such areas are categorized as microgrid, including remote areas, desert and border-outpost moveable military equipment, street light systems, etc. However, the power generation is significantly influenced by the light intensity and the temperature. In addition, PV cells cannot store the energy inside; thus, an energy storage device is normally required to balance the energy of the PV systems.

In such types of distributed-sourced microgrid systems, the multiple connection issues of the SPVS to grid have been considered previously and some solutions using droop control methods have been provided. In the design procedure of the individual SPVS architecture, one of the major concerns is the need of a high output dc-voltage bus (400 Vdc) inside the individual SPVS to supply the following inverter from the low voltage power sources. Since a commercialized battery bank voltage is relatively low, such as 12, 24, or 48 V, a power conditioning unit (PCU) is required to interface the battery to dc-link bus with high step-up ratios. This issue has led to many multiple stage PCU topologies.

A conventional topology used widely for an SPVS, including an energy storage device connected with the dc link through a bidirectional dc–dc power converter was proposed Fig. 1 (a).

This power converter acts as a step-up converter when the stored energy flows from the battery bank to the dc-link bus (discharging mode) and as a step-down converter when the energy flows from the dc link to the battery bank (charging mode). The controller regulates the dc-link voltage and another dc–dc converter associated with PV source performs an maximum power point tracking (MPPT) operation for the PV source. As aforementioned, because the dc-link bus voltage is usually very high (for most applications), the bidirectional dc–dc converter needs to have a high step-up gain along with a high efficiency. It is difficult to achieve the high efficiency and the high

gain simultaneously in conventional bidirectional dc–dc converters due to the losses in semiconductor devices, leakage inductance, and other parasitic elements.

Another traditional stand-alone PV system architecture is that whereby the energy storage device (battery) is placed between the first dc/dc and the dc link, or the battery is interfaced with the dc link by the second dc/dc converter shown in Fig. 1.1 (b). In case without the second dc/dc converter, the first dc/dc converter performs MPPT while the dc/ac inverter regulates the ac output voltage.

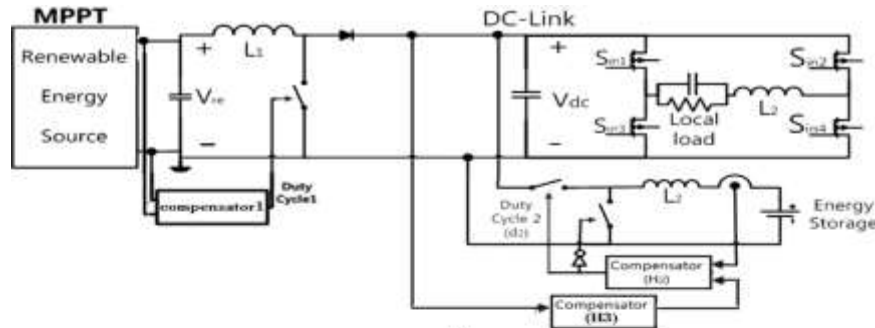

Fig-1: Convectional circuits of the SPVS proposed in previous literature with Storage-to-dc link [24].

Despite the advantages of this configuration (such as reducing the number of power converters), it also has some disadvantages such as a high-voltage battery, which leads to stacking up of the multiple battery modules. Furthermore, the battery current is uncontrollable; thus, when the load changes abruptly, it often damages the battery due to the large transient current. Also, there can be a small cycle of charging and discharging in the battery from the consistent power flow during the operation, which causes a serious reduction of battery lifetime.

In order to overcome these drawbacks, the secondary dc/dc converter is normally added to this configuration. However, the battery is still involved in energy conversion, affected by load disturbance directly, which could seriously affect the battery life-time and utilization. Recently proposed topology of an SPVS is classified as a three-port converter as shown in Fig. 1. (c). The main advantages of this topology are the low voltage stress across the active switches, the low input current ripple, etc. However, the architecture and the control method are quite complex and the control architecture is difficult to instantaneously adapt for multiple mode variation. In addition, a multiport ac link, proposed by Amirabadi *et al.* [35] as an alternative configuration for SPVS, is a configuration that utilizes many high-frequency switches, which leads to low efficiency of the overall system. Main advantages of this topology are the low voltage stress across the active switches, the low input current ripple, etc. However, the architecture and the control method are also quite complex and the control architecture is difficult to instantaneously adapt for multiple mode operation, as well.

In this Paper, a flexible system configuration for an SPVS with an energy storage device is proposed.

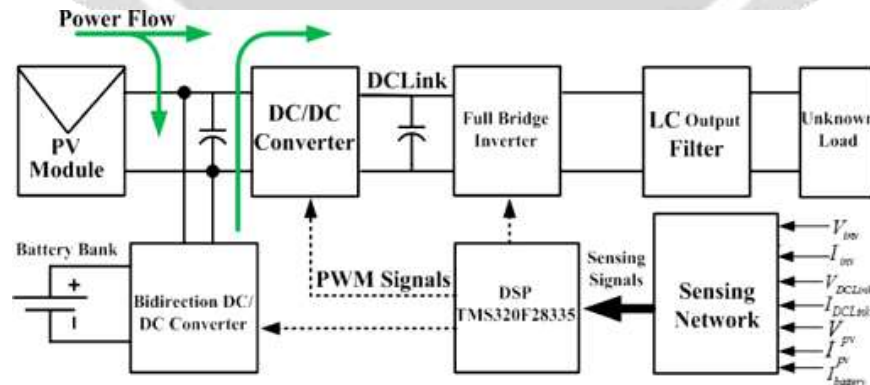

Fig-2: Topology of the storage-to-PV SPVS.

The principle of the proposed architecture and its advantages and operating modes are described in Section II. The PV modeling, small signal model, and control strategy of the converters are analyzed in Section III. An analysis of the strategy of the dc/ac using slidingmode control (SMC) method is presented.

2. PROPOSED PV-STORAGE SYSTEM ARCHITECTURE

The proposed SPVS is shown in Fig. 2 and consists of a PV panel, batteries, two converters, and a single-phase dc/ac inverter. The boost converter (BC) is used to maintain the dc-link voltage, while the charging or discharging mode of the bidirectional dc/dc converter is applied to track the MPPT of the PV array when the available PV power is insufficient to meet the load. Therefore, the two dc/dc converters in the system need to be coordinated by an upper level controller. One of the key features of the proposed stand-alone system is that the storage subsystem is connected to the PV module directly. This configuration provides a flexible smooth operation for the system, since the role of the main PV power stream and that of the storage subsystem are clearly separated from each other. The system could work with and without battery both, without any major mode change in the local controllers, which is preferable from industrial point of view.

The proposed system architecture makes the switch between the different modes of operation smooth and simple without the need for supervisory controller. Furthermore, this arrangement provides more flexibility in choosing the battery's nominal voltage with a reasonable step-up ratio. It also stores the excess PV energy in the battery to balance the system and supplies the instantaneous peak power demand. One of the main concerns in the previous architecture is the battery voltage, which needs stacking up of multiple packs to enhance the voltage range. Actually, the stacking up requires a balancing circuit, a so-called charge balancer, which makes the system structure more complicated, resulting in an undesirable configuration in terms of the size and cost competitiveness. Also, some safety issues are observed, whereby the high-voltage dc lines can cause fatal damage to the human body since the battery is alive even during the main power system turn-off; the voltage range should therefore meet the electrical safety standard and regulations of the IEEE and the IEC.

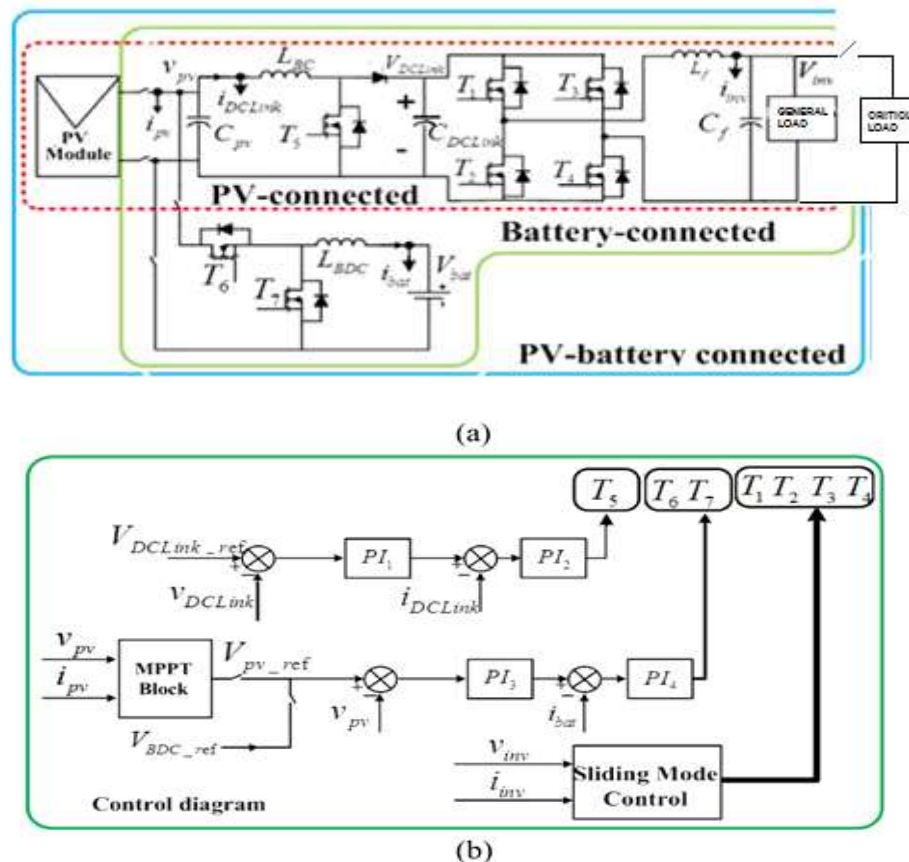

Fig-3: Block diagram of the overall system configuration of the SPVS.(a) Power stage. (b) Control strategy

Therefore, the proposed scheme is more desirable for the PV-storage combination system. In the previous section, it has already been seen that the battery voltage in the conventional schemes should be greater than 100 V because of a fundamental characteristic that the bidirectional converter (BDC) should discharge the battery energy to 400 V dc

link. The requirement removes all the advantages of the low-voltage battery and the flexibility from the conventional architectures. Five flexible operation modes are possible for the proposed scheme. These modes depend on the power producing and energy-storing conditions, as follows.

1. Mode I—PV-storage connected ($P_{MPP} < P_{load}$): The PV is not enough to meet load demand, so the battery bank is discharged to meet the load demand. The BDC discharges the stored energy to the input of PV PCS, and the BC enhances PV voltage up to the 400 V dc link.
2. Mode II—PV-connected ($P_{MPP} < P_{load}$): If the battery becomes fully discharged, or when the battery bank is removed, the system enters the non-MPPT mode or under voltage lockout and shuts down.

TABLE-I: Operation Modes

Modes	Power Condition	Battery Condition	PV Condition
I	$P_{MPP} < P_{load}$	discharging	MPPT
II	$P_{MPP} < P_{load}$	Fully discharged	Non-MPPT
III	$P_{MPP} > P_{load}$	Charging	MPPT
IV	$P_{MPP} > P_{load}$	Fully charged	Non-MPPT
V	$P_{MPP} = 0, P_{bat} = P_{load}$	Discharging	Non-MPPPT

3. Mode III—PV-storage connected ($P_{MPP} > P_{load}$): The harvested power exceeds the load and the battery is charged with the excess power, until the battery is fully charged. Electric power can flow from the PV source to the load as well as charge the battery.
4. Mode IV—PV-connected ($P_{MPP} > P_{load}$): If the battery is fully charged, the battery bank should be disconnected from the PV power conditioning system. The MPPT must be disabled (non-MPPT), and the PV voltage reference is set at constant to hold the CPV voltage, providing the load-power tracking.
5. Mode V—Battery-connected (nighttime): When PV sources do not produce sufficient power for the load, for example, at night or on a cloudy day, the PV modules are disconnected from the power conditioning system. P_{load} is provided only by the battery through cascading the BC, BDC, and full-bridge inverter. Such a cascaded operation makes it possible to step up the voltage from 24 Vdc, given by the battery bank, up to 400 Vdc to feed the dc/ac inverter and the load. The PV-voltage loop reference of the control loop of the BDC switches simply to a constant value instead of the perturbed step of MPPT.

The summary of operation modes is shown in Table I. Fig. 3 shows the flexible system configuration to realize each mode. In order to ensure the previous multistage power conditioning system such as SPVS operations with a stable response and a negligible steady-state error, some complex controllers were proposed previously. Among the proposed controllers, a linear controller based on proportional-integral-derivative (PID) was widely used and discussed. However, since these controllers require precise linear mathematical models, the PID family of controllers does not perform satisfactorily under parameter variation, nonlinearity, load disturbance, etc. Thus, in the previous literature, various control laws were proposed to handle the issue. One of the state-of-the-art technologies for the troubleshooting is to use a nonlinear controller in order to improve the power quality under arbitrary loads.

In this paper, a novel strategy that combines a multi-loop proportional-integral (PI) controller and an SMC law is presented. The multi loop PI is used to control the operation of the dc/dc converters, whereas the SMC law is utilized for the output regulation of the dc/ac inverter due to its robustness and good performance with any type of unknown arbitrary load. In this paper, a simple algorithm of SMC that is easy to implement using digital signal processor (DSP) is applied. In this paper, all the power converters used for the SPVS as shown in Fig. 3(a) operate at 20 kHz switching frequency. The overall control strategies of the SPVS are shown in Fig. 5.3(b). This system has a number of advantages. First, the flexibility for various types of operating modes, with and without energy storage, is strongly guaranteed without the control configuration change. Second, the system can be applied even with a single 24 V commercial battery without any extra connection. The key feature of the configuration is that the control part [see Fig. 5.2(b)] does not change, even though the power stage varies according to the operating modes. The feature guarantees large flexibility and compatibility to the system.

3. DC/DC CONVERTER CONTROLLER

In this paper, a generalized small signal model is derived for the BC and BDC, including an input PV source, which has not been fully discussed in previous studies. In order to design the optimized controller using a bode plot, the

Parameter	Value
$V_{PV} (max)$	100 V
$I_{PV} (max)$	4 A
R_{eq}	25 Ω
V_{bat}	24 V
L_{BDC}	1.8 mH
C_{PV}	2200 μF
L_{BC}	1.8 mH
C_{dec_link}	1300 μF
f_{sw}	20 kHz

TABLE-III: Circuit Parameters Used In Pv Design

PV Model	SPVS310W
Maximum power (P_{max})	310 W
Open-circuit voltage (V_{oc})	120 V
Maximum power voltage (V_m)	100 V
Short-circuit current (I_{sc})	3.5 A
Maximum power current (I_m)	3.1 A

The table II and III represents the list of parameters used in simulation in designing the proposed circuit SMC controller.

5. SIMULATION OF THE PROPOSED WORK

The analysis of the proposed system has done using MATLAB Simulink Software. The Fig-6 to Fig-9 shows the overall circuit design, battery charging/discharging control, MPPT and SMC control of the system.

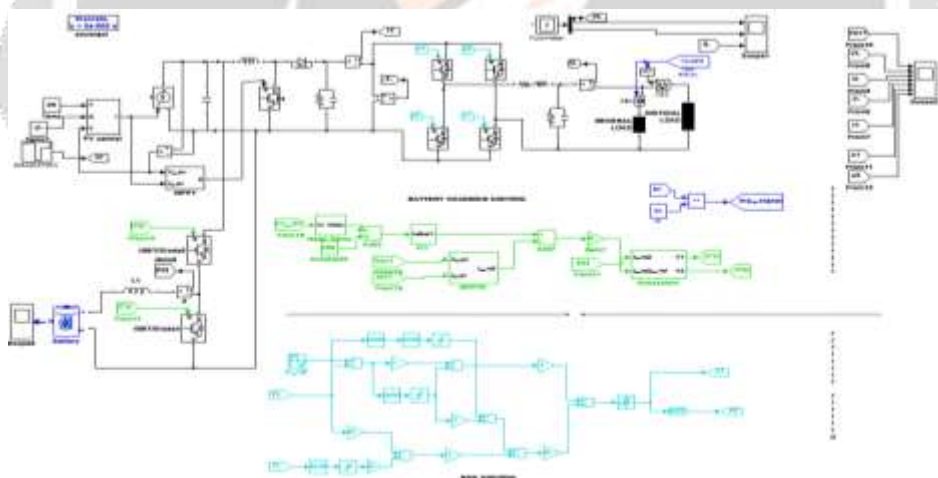

Fig-6: MATLAB design of the proposed Overall system

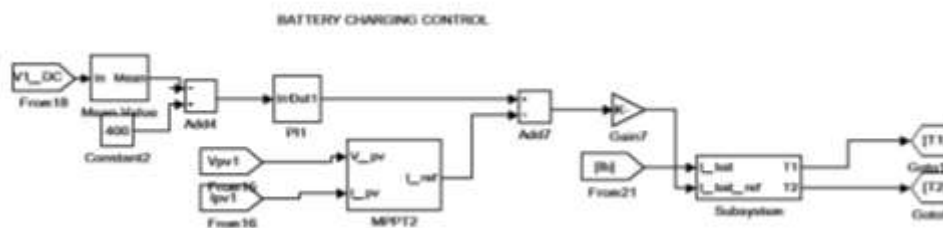

Fig-7: MATLAB design of battery charging/discharging control

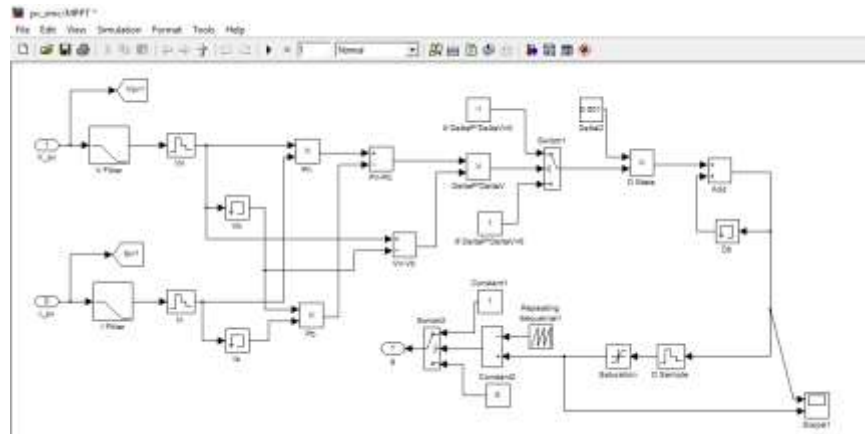

Fig-8: MPPT control Solar PV system

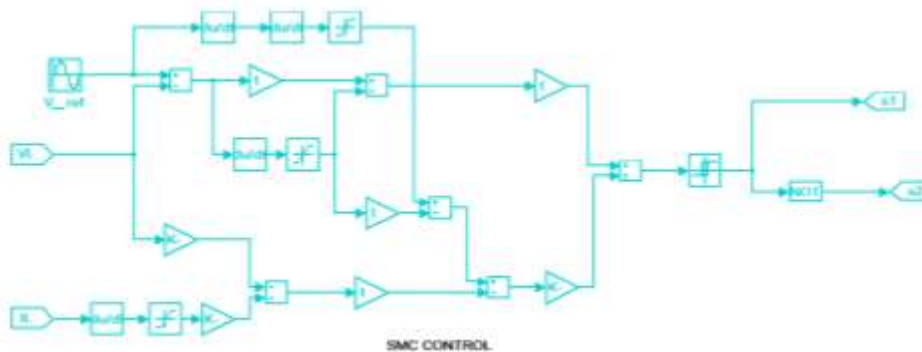

Fig-9: Sliding Mode Control system

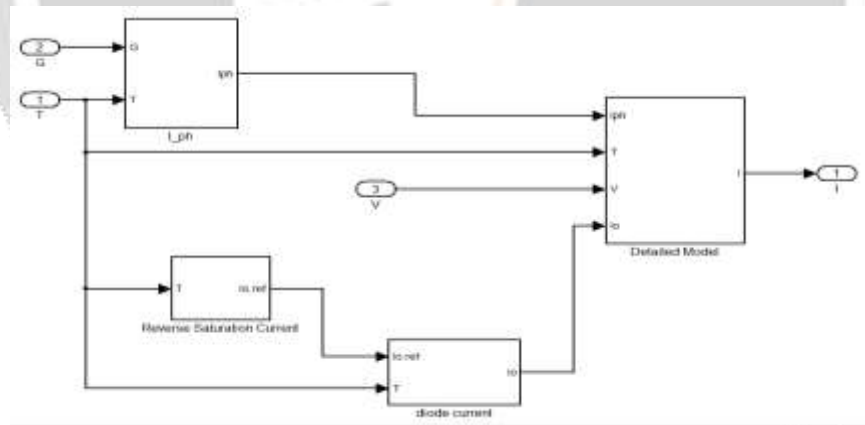

Fig-10: Equivalent circuit of Solar PV system used in MATLAB design of PV system

The Fig-10 shows the equivalent circuit of solar PV system designed using MATLAB software and Fig-11 & 12 shows the results of proposed system.

In the case of nominal irradiation of solar i.e 1000 or 500-1000 a general load is feeded and while the irradiation is below 500 then supply is given to critical load so as to increase the utilization and efficiency.

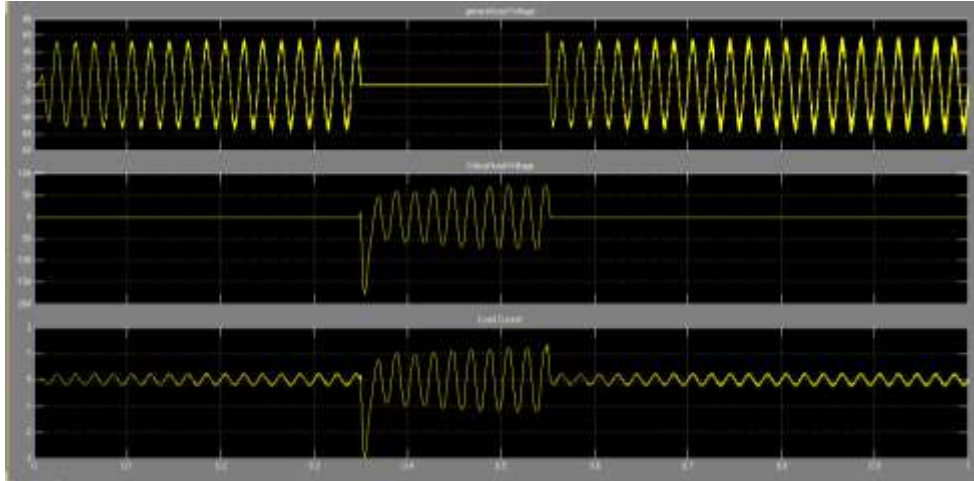

Fig-11: Output voltages of general load, critical load and load current of proposed system

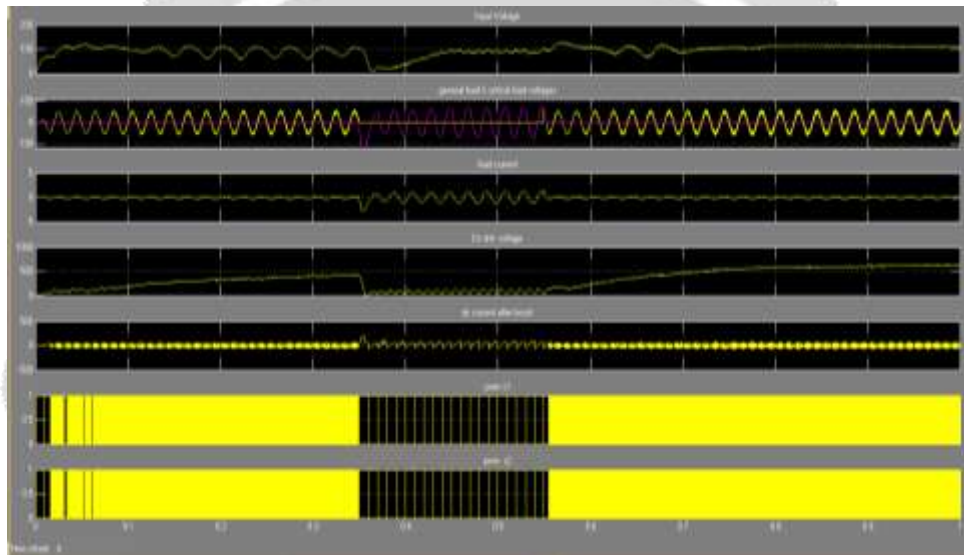

Fig-12: Input, Output parameters and Duty pulses

6. CONCLUSION

In this paper, the dynamic-response analysis and the controller-design procedure of the flexible power flow management of renewable energy system including the lead-acid batteries as the energy storage devices, are studied. The control system successfully controlled in a variable operation condition and the control strategy achieves fast and accurate control of the inverter output voltage and step-load changes. From the proposed control architecture of the PV-storage system, multiple operating modes such as general load and critical load are allowed without any instantaneous control configuration changes. The simulation tests are verified by utilizing a 36-V battery bank; actually, the SPVS can also operate well when associated with a 24 V commercial single battery. The proposed topology, along with its control strategy, is very practical because of the flexibility of the configuration and the controlling strategy of the bidirectional dc/dc converter and dc/ac inverter is simple and strong. As a result, it is compatible with a conventional PV or battery systems without any control configuration modification. This topology is highly promising for a commercial product of PV conversion systems.

7. REFERENCES

- [1] B. Bose, "Global warming: Energy, environmental pollution, and the impact of power electronics," *IEEE Ind. Electron. Mag.*, vol. 4, no. 1, pp. 6–17, Mar. 2010.

- [2] F. Katiraei and J. R. Agüero, "Solar PV integration challenges," *IEEE Power Energy Mag.*, vol. 9, no. 3, pp. 62–71, May/June. 2011.
- [3] D. A. Halamay, T. K. A. Brekken, A. Simmons, and S. McArthur, "Reserve requirement impacts of large-scale integration of wind, solar, and ocean wave power generation," *IEEE Trans. Sustain. Energy*, vol. 2, no. 3, pp. 321–328, Jul. 2011.
- [4] M. Fazeli, J. B. Ekanayake, P. Holland, and P. Iqic, "Exploiting PV inverters to support local voltage—A small-signal model," *IEEE Trans. Energy Convers.*, vol. 29, no. 2, pp. 453–462, Jun. 2014.
- [5] H. R. Teymour, D. Sutanto, K. M. Muttaqi, and P. Ciufo, "Solar PV and battery storage integration using a new configuration of a three-level NPC inverter with advanced control strategy," *IEEE Trans. Energy Convers.*, vol. 29, no. 2, pp. 354–364, Jun. 2014.
- [6] M. J. E. Alam, K. M. Muttaqi, and D. Sutanto, "A novel approach for ramp-rate control of solar PV using energy storage to mitigate output fluctuations caused by cloud passing," *IEEE Trans. Energy Convers.*, vol. 29, no. 2, pp. 507–518, Jun. 2014.
- [7] R. Shah, N. Mithulananthan, and K. Y. Lee "Large-scale PV plant with a robust controller considering power oscillation damping," *IEEE Trans. Energy Convers.*, vol. 28, no. 1, pp. 106–116, Mar. 2013.
- [8] C. Huang-Je, L. Yu-Kang, Y. Chun-Jen, and C. Shih-Jen, "Design and implementation of a photovoltaic high-intensity-discharge street lighting system," *IEEE Trans. Power Electron.*, vol. 26, no. 12, pp. 3464–3471, Dec. 2011.
- [9] J. Margeta and Z. Glasnovic, "Introduction of PV energy into an existing HEP," *IEEE Trans. Energy Convers.*, vol. 28, no. 1, pp. 717–727, Sep. 2011.
- [10] C. Wang and M. H. Nehrir "Power management of a stand-alone wind/photovoltaic/fuel cell energy system," *IEEE Trans. Energy Convers.*, vol. 23, no. 3, pp. 957–967, Sep. 2008.
- [11] R. B. Billinton "Evaluation of different operating strategies in small standalone power systems," *IEEE Trans. Energy Convers.*, vol. 20, no. 3, pp. 654–660, Sep. 2005.
- [12] R. B. Billinton "Incorporating well-being considerations in generating systems using energy storage," *IEEE Trans. Energy Convers.*, vol. 20, no. 1, pp. 225–230, Sep. 2005.
- [13] T. Dragicevic, J. M. Guerrero, J. C. Vasquez, and D. Skrlec, "Supervisory control of an adaptive-droop regulated DC microgrid with battery management capability," *IEEE Trans. Power Electron.*, vol. 29, no. 2, pp. 695–706, Feb. 2014.
- [14] V. Nasirian, A. Davoudi, F. L. Lewis, and J. M. Guerrero, "Distributed adaptive droop control for DC distribution systems," *IEEE Trans. Energy Convers.*, vol. 29, no. 4, pp. 944–956, Dec. 2014.
- [15] L. Xiaonan, S. Kai, J. M. Guerrero, J. C. Vasquez, and H. Lipei, "State-of charge balance using adaptive droop control for distributed energy storage systems in dc microgrid applications," *IEEE Trans. Ind. Electron.*, vol. 61, no. 6, pp. 2804–2815, Jun. 2014.
- [16] S. Daher, J. Schmid, and F. L. M. Antunes, "Multilevel inverter topologies for stand-alone PV systems," *IEEE Trans. Ind. Electron.*, vol. 55, no. 7, pp. 2703–2712, Jul. 2008.
- [17] S. Malo and R. Grino, "Design, construction, and control of a stand-alone energy-conditioning system for PEM-type fuel cells," *IEEE Trans. Power Electron.*, vol. 25, no. 10, pp. 2496–2506, Oct. 2010.
- [18] W. Li, W. Li, Y. Deng, and X. He, "Single-stage single-phase high-step-up ZVT boost converter for fuel-cell microgrid system," *IEEE Trans. Power Electron.*, vol. 25, no. 12, pp. 3057–3065, Dec. 2010.
- [19] H. Fakhm, D. Lu, and B. Francois, "Power control design of a battery charger in a hybrid active pv generator for load-following applications," *IEEE Trans. Ind. Electron.*, vol. 58, no. 1, pp. 85–94, Jan. 2011.