

# BATTERY AND SUPERCAPACITOR-BASED HYBRID ENERGY STORAGE SYSTEMS

<sup>1</sup>Akanksha Patel, <sup>2</sup>Varsha Sharma

<sup>1</sup>Student, <sup>2</sup>Assistant Professor

<sup>1</sup>Department of Electrical and Electronics

<sup>1</sup>RSR Rungta College of Engineering and Technology, Bhilai (C.G.), India

## Abstract

Because of their power density, energy density, charging and discharging cycles, life duration, and wide operating temperature range, battery and super capacitor devices are argued to be among the most important storage technologies in this article. A battery energy storage system (BESS) does not compare favorably to a hybrid energy storage system (HESS), which includes both batteries and super capacitors. HESS recycles surplus energy. A hybrid energy storage system that is compatible with renewable energy sources such as solar and wind is proposed in this research. Such a system might be employed for energy storage in remote or backup systems that do not have access to a power grid. Hybrid energy storage systems are compatible with renewable sources of power like solar and wind. In order to achieve the highest possible level of efficiency, this system will make use of super capacitors in parallel with the battery and a periodic load. This investigation also includes a MATLAB/Simulink model of a hybrid energy storage system consisting of batteries and super capacitors.

**Index Terms** - Hybrid Energy Storage System (HESS), Battery Energy Storage System (BESS), Energy Storage System (ESS), Photovoltaic (PV), Super Capacitor (SC), Super Capacitor Energy Storage System (SCESS) System, Battery-Super capacitor-based hybrid energy storage system (BSHESS).

## I. INTRODUCTION

Conversion of the excess electricity into the different form of energy which can be reconverted into electrical energy known as energy storage system (ESS). Energy storage system (ESS) stored in the form of mechanical energy, electrostatic, electrochemical energy, thermal energy etc. and we can use the stored energy whenever the need arises, it can be applied to both conventional source of electricity and renewable energy sources, but among them we focus on battery and super capacitor energy storage systems. When demand is high compare to supply then un-uniformity between demand and supply, due to this power system is unbalanced and many problems introduced in power grid like decrease power quality, decrease efficiency, decrease reliability and stability of system and introduces many losses which is reduced by ESS system.

### 1.1 Advantages of energy storage system (ESS)

- A. Increase dispatch ability
- B. Makes power available on demand
- C. Reduce gap between supply and demand
- D. Compensated for intermittency of renewable energy such as solar and wind
- E. Electricity stored during the off-peak time can be used during on peak hours. Energy storage system (ESS) integrated with photovoltaic can maximize consumption of the solar energy by using electricity stored peak.

Energy storage systems (ESS) provide a variety of benefits, including increased efficiency, dependability, availability, and cost effectiveness for a wide range of applications. These applications include the power grid, renewable power sources, electric vehicles and hybrid electric vehicles, and so on. Energy storage helps maintain smart grids in balance. The movement towards cleaner energy and transportation has a significant impact on the field of electrical energy; thus, in order for energy storage to develop into a comprehensive solution, it is necessary to address these flows. New developments have been made possible in the field of clean energy thanks to the introduction of high-energy storage capacitors (also known as super capacitors) that have a higher power density,

as well as lighter rechargeable batteries that have a better energy density.

## II. RESEARCH METHODOLOGY

### 2.1 BATTERY ENERGY STORAGE SYSTEM (BESS)

In rural and distant places, standalone power systems that service a variety of electrical demands frequently make use of renewable energy sources including wind energy and photovoltaic (PV) energy. These are sources of electricity that are sporadic in nature; hence, stand-alone power systems need to incorporate them. storage battery bank Because of the extra energy that is stored in the battery bank, the storage battery banks make the systems more reliable. This is because the energy that is stored in the battery bank is the energy that is provided to the load bank at times when the energy from the sun or the wind is either unavailable or insufficient. When it comes to storage battery banks, lithium ion and lead acid batteries are the most common types employed. Battery energy storage systems (BESS) need to have their batteries replaced on a regular basis, and should do so after several hundred charging and discharging cycles at the very least.

#### 2.1.1. Lead Acid Battery

The energy storage system (ESS) industry recognizes the benefits of lead-acid batteries, including their high energy density, efficiency, long battery life, cheap cost, and environmental friendliness. Batteries that use lead acid have a relatively cheap cost per unit of energy, making them appropriate for use in large-scale energy storage applications. Batteries that employ lead acid may be used both in situations with pulsing power loads and those with steady power loads.

#### 2.1.2. Lithium Ion Battery

Lithium ion batteries have greater energy density, high life span, high efficiency, weight loss, eco-friendly compare to lead acid batteries and but it is of higher cost. Lithium ion batteries are widely used for mobiles and automobiles applications etc.

### 2.2 HYBRID ENERGY STORAGE SYSTEM (HESS)

Hybrid energy storage systems combine multiple energy storage systems. This paper utilizes BESS and SCESS. The battery-super capacitor based hybrid energy storage system (BSHESS) increases the efficiency of the photovoltaic system by providing energy during nighttime and sunless periods, meeting peak power demands, stabilizing the system voltage, and improving its capabilities. Battery-Super Capacitor hybrid energy storage systems (HESS) are too expensive for large-scale deployment and uniform load demand. A hybrid storage system with a super capacitor and a good simulation model can provide more specific power than a BSS. This is because the hybrid system changes the efficiency of the system. Because super capacitors have a higher power density, they are able to offer more power in a shorter amount of time. Alternatively, super capacitors can supply peak power for a shorter length of time. This means that the charging capacity of hybrid storage systems can rise thanks to super capacitors. To raise the buffer level is the primary responsibility of the super capacitor (SC) component of the hybrid energy storage system (HESS). The super capacitor is responsible for meeting the load's peak power requirements, while the battery delivers the lower continuous power demand. This combination allows for a decrease in the battery pack size while maintaining a high level of storage capacity. Battery has a much higher density due to this battery store more energy and release it over a long period of time means we can say battery increase the storage capacity of system and decrease the discharging capacity of hybrid system.

#### 2.3 Advantages of battery-super capacitor based hybrid energy storage system (BSHESS)

- A. Thrust for renewable energy sources
- B. Long cycle life
- C. Energy Buffering
- D. Increase Reliability
- E. High Cycle efficiency
- F. Low self-discharge rate
- G. High energy and power density
- H. Improve the uniformity and efficiency

- I. Improve the electricity system performance
- J. Low cost and light weight for large scale deployment

## 2.4 MODELLING OF BATTERY/SUPER CAPACITOR HYBRID ENERGY STORAGE SYSTEM (HESS)

MATLAB/Simulink software creates a practical and systematic hybrid battery-super capacitor system model. The model includes battery, super capacitor, DC voltage source (PV cell), converter circuits, load, and internal losses. MATLAB/Simulink simulations of the battery/super capacitor hybrid system have proven that our model can properly estimate real-world hybrid system energy use.

### 2.4.1 Modeling of battery energy storage system (BESS)

The design and operation of the PV system, as well as the type of battery technology that is utilized, all have an impact on the performance of the battery. The majority of solar photovoltaic applications will make use of the lead acid battery technology. A battery model that is fundamentally based has been created, and it has been integrated into the PV module.

Modeling of the BESS using MATLAB/Simulink as shown in figure 1.

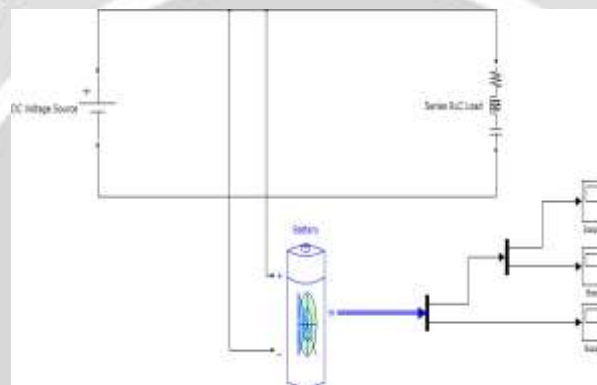

Figure 1: Modeling of Battery

Battery (Lead acid/Lithium ion) is in parallel with DC voltage source and load (R/RL/RLC) , we can choose different values of DC voltage source, load, battery after simulation analyze the outputs {voltage from input source, discharge current and state of charge (SOC)}of the designed model in MATLAB/Simulink software.

### 2.4.2 Modeling of Battery-Super Capacitor HESS

Modeling of Battery-Super Capacitor based hybrid energy storage system using MATLAB as shown in figure 2.

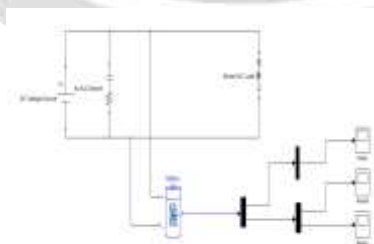

Figure 2: Modeling of Battery-Super capacitor

In the above figure high capacity capacitor is connected in parallel with DC voltage source, load and battery. According to the requirement we can choose the different values of DC voltage source, load, battery after simulation analyze the outputs {voltage from source connected, discharge current and state of charge (SOC)} of the designed model in MATLAB/Simulink software.

### 2.4.3 Modeling of BSHESS with Converters

Converter is used in HESS for voltage regulation and work as an energy transduction. Designed model of the BSHESS with converter in MATLAB 2010 as shown in figure 3

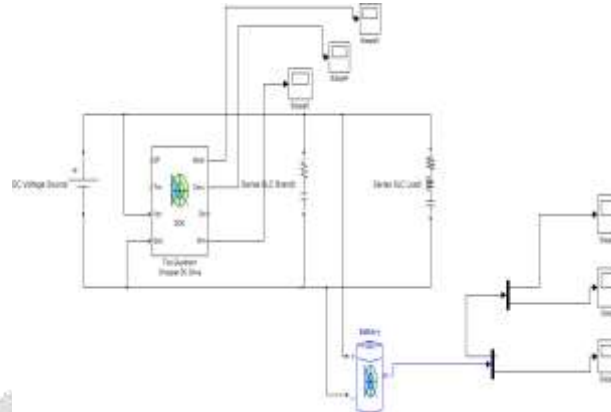

Figure 3: Modeling of Battery-Super Capacitor with Converter

Battery and Super Capacitor are connected in parallel with DC voltage source and load connected and converters are also used in this system, according to the requirement we can choose the different values of DC voltage source, load, battery after simulation analyze the outputs {voltage from source connected, discharge current and state of charge (SOC)} of the designed model in MATLAB.

### 2.5 RATING OF BATTERY AND SUPER CAPACITOR

We can calculate Rating of Battery and Super Capacitor for given PV system according to the requirement of consumer load and demand hours. The shown below calculation gives an idea for calculating Rating of Battery and Super Capacitor for given PV system.

#### 2.6 CALCULATION FOR 80 Watt SOLAR PV SYSTEM FOR 10hr LOAD

Total load consumption= Volt\*Amper\*Hours

$$= V * I * h$$

$$= 80 * 10$$

$$= 800W \text{ or } 0.8KWh$$

Battery Rating

$$\text{Let the Battery Rating} = 12V/75Ah$$

$$= 12V * 75Ah$$

$$= 900VAh \text{ or } 0.9KWh \text{ (approx.)}$$

Super Capacitor Rating

We know that  $Q = C * V$

$$Q = \text{Amper} * \text{Time} \quad C = Q/V$$

$$C = 75/12$$

$$C = 6.25 \text{ Farad} \text{ Therefore super capacitor rating is } 6F/12V \text{ (approx.)}$$

Solar panel calculation

Total voltage of solar panel= 17.0 volts

Amperage of it= 4.7 to 5 Amp.

Power of panel=  $V * I = 17 * 4.7 = 79.9 \text{ Watt}$

= 80 Watt (approx.)

### 2.7 Application of HESS

- A. Load labeling
- B. Peak Saving
- C. Voltage Regulation

- D. Capacitive Firming
- E. Frequency Regulation
- F. Power Quality
- G. Spinning Reserve

### III. Proposed System with Power Management

The requested energy by the load and the produced energy by the PV arrays, are presented as random input data to the system to validate the energy

management algorithm strategy. In Figure 4, a bi-directional buck-boost converter is used and Figure 5 illustrates the detailed components of the converter. The bi-directional converter is used to charge and discharge the super-capacitor, in relation to the availability of energy. However, this converter contains an inductance and two electronics switches, which are controlled in complementary way (they can be either off or if the first is on the second is off). Figure 5.6 shows the details for the energy data manipulation of the load and the PV arrays which are also used in the proposed system in Figure 4.

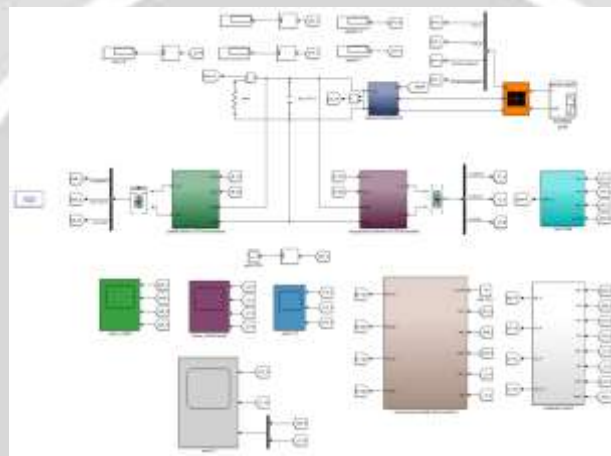

Fig4: Overall System

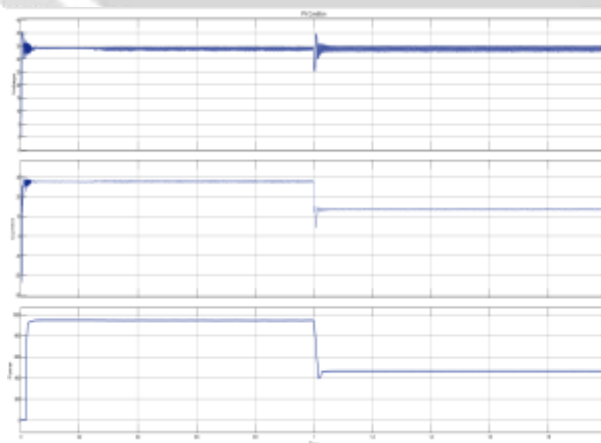

Fig 5 Solar power Response

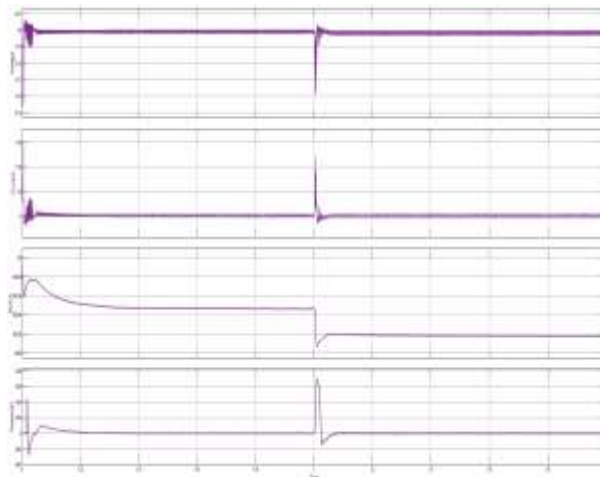

Fig 6: Battery Response with Super capacitor

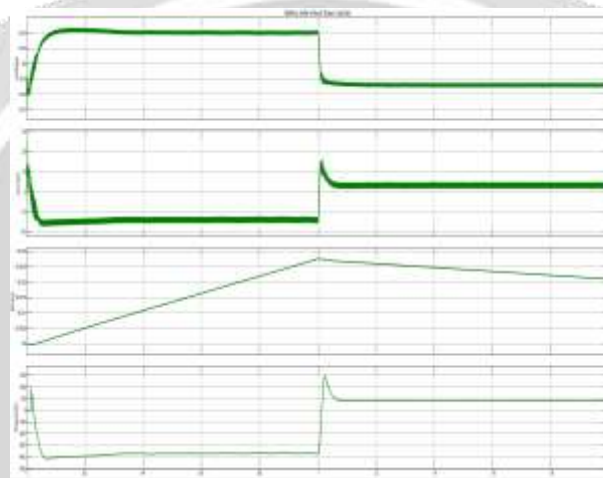

Fig 7 Battery Response without Super capacitor

### III. Future Scope

The traditional battery energy storage system (BESS) is going to be phased out and replaced by a hybrid energy storage system consisting of batteries and super capacitors. This hybrid energy storage system might be used in a small scale deployment as well as a large scale deployment in many different areas, such as rooftop solar power plants, street solar lights, electrical cars, inverters in households, government projects, renewable energy storage, solar farms, and many other similar sectors. The following are examples of government initiatives in India that call for the planned hybrid energy storage system (HESS) to be implemented:

- 1) The National Smart Grid Mission (NSGM) has been given approval by the Ministry of Power. This mission includes aggressive aims for Micro grids, which will call for the development of energy storage technologies.
- 2) In April of 2015, the government of India established the Nation Electric Mobility Mission (NEMM), with the intention of producing 6-7 million electric vehicles by the year 2022.
- 3) A policy known as "net metering," which allows customers to have the option of installing solar panels on their roofs. The vast majority of systems will make use of inverters and with batteries.
- 4) The Government of India has established targets for renewable energy. In order to accomplish these Renewable Energy Targets, the integration of renewable energy sources will need the development of energy storage technologies.

### IV. CONCLUSION

To provide a BSHESS. Modeling of BESS and modeling of HESS by Battery-Super Capacitors and with Convertors is carried out by the MATLAB/Simulink. In order to get highest efficiency from this hybrid system, super capacitor will be used in parallel with the battery and a pulse load. Model of this hybrid system is designed on MATLAB/Simulink. This proposed system reduces the disadvantages of BESS by using super capacitor in parallel with battery and load.

Rating of battery and super capacitor can be calculated and used for remote or backup energy storage system if the power output and demand hours are given for any PV system or any power grid.

## V. REFERENCES

- [1] M.E. Glavin, W.G. Hurley “ULTRACAPACITOR/ BATTERY HYBRID FOR SOLAR ENERGY STORAGE”.
- [2] M.E. Glavin, Pau I K .W. Cha n, S. Armstrong, and W.G Hurley, IEEE Fellow “A Stand- alone Photovoltaic S u per capacitor Battery Hybrid id Energy Storage System”.
- [3] Pedro C. Elizondo – ABB Inc. – March 2014 “Battery Energy Storage Systems (BESS)” For peak shaving and demand management
- [4] Ola Subhi Waheed Al-Qasem “Modeling and Simulation of Lead Acid Storage Batteries within Photovoltaic Power Systems” An-Najah National University Faculty of Graduate Studies.
- [5] Pierre - O livier Logeris, Olivier Riou, Mohamed Ansoumane Camera, and Jean-Félix Durastanti “Study of Photovoltaic Energy Storage by Super capacitors through Both Experimental and Modeling Approaches” Hindawi P ublishing Corporation Journal of Solar Energy Volume 2 013, Article ID 659 014, 9 pages <http://dx.doi.org/10.1155/2013/659014>.
- [6] Eng. Vincenzo Musolino, matriculation number: 738557 PhD Thesis in Electrical Engineering XXIV Cycle 2009-2011 “SUPERCACITOR STORAGE SYSTEMS: MODELING, CONTROL STRATEGIES, and APPLICATIONS AND SIZING CRITERIA”.
- [7] Xing Luo, Jihong Wang, Mark Dooner, Jonathan Clarke “Overview of current development in electrical energy storage technologies and the application potential in power system operation”.
- [8] Feng Ju, Qiao Zhang, Weiwen Deng and Jingshan Li “Review of Structures and Control of Battery-Super Capacitor Hybrid Energy Storage System for Electric Vehicles” 2014 IEEE International Conference on Automation Science and Engineering (CASE) Taipei, Taiwan, August 18-22, 2014.
- [9] ECE 480 Design Team 10 Final Report “Battery–Super capacitor Hybrid Energy Storage System”
- [10] Grid Energy Storage, U.S. Department of Energy, December 2013.
- [11] A Guide to Understanding Battery Specifications MIT Electric Vehicle Team, December 2008.
- [12] Mario A. Silva, Hugo Neves de Melo, Joao P. Trovao Paulo G. Pereirinha, Humberto M. Jorge “Hybrid Topologies Comparison for Electric Vehicles with Multiple Energy Storage Systems” EVS27 Barcelona, Spain, November 17 - 20, 2013.
- [13] NEERAJ KULDEEP, KARTHIK GANESAN, VAIBHAV GUPTA, ADITYA RAMJI, KANIKA CHAWLA AND MANU AGGARWAL “Energy Storage in India” Applications in the Renewable Energy Segment, CEEW Report November 2016, [ceew.in](http://ceew.in) .
- [14] Johanna Gustavsson “Energy Storage Technology Comparison” A knowledge guide to simplify selection of energy storage technology, Bachelor of Science Thesis, KTH School of Industrial Engineering and Management Energy Technology EGI-2016 SE-100 44 STOCKHOLM.