

Beam Zooming based on Wideband Beam Tracking for Delay Phase Precoding

¹S.Subramanyam,²K.Shivani,³K.Saipriyanka,⁴K.Rakesh,⁵P.Nikhil Kumar

¹Assistant Professor, Electronics and Communication Engineering, Jyothishmathi Institute of Technology and Science, Karimnagar, Telangana-505481.

^{2,3,4,5}B.Tech final year students, Electronics and Communication Engineering, Jyothishmathi Institute of Technology and Science, Karimnagar, Telangana-505481.

Abstract: Terahertz (THz) multiple-input multiple-output (MIMO) is becoming a promising technology for future 6G network, where using beam tracking scheme to track mobile users is essential. However, existing beam tracking schemes designed for narrowband systems with the traditional hybrid precoding structure suffer from severe performance loss caused by the wideband beam split effect. To solve this problem, we propose a beam zooming based beam tracking scheme by considering the recently proposed delay-phase precoding structure. At first, we prove the beam zooming mechanism to flexibly control the angular coverage of frequency-dependent beams over the whole bandwidth, i.e., the degree of the wideband beam split effect, which is achieved by the elaborate design of time delays in the delay-phase precoding structure. Based on this mechanism, we then propose to track multiple physical directions in each time slot by generating multiple beams. The angular coverage of these beams are flexibly zoomed to match the angular variation range of user physical direction. After several time slots, the base station can obtain the new physical direction by finding out the beam with the largest received power. The proposed scheme can track multiple physical directions simultaneously with reduced training overhead, which is verified by simulation results.

Keywords: THz: massive MIMO: beam tracking.

1. INTRODUCTION

Over several decades, the amount of wireless voice and data communications has demonstrated potential development, which is referred to as Cooper's law. In the 1990s, wireless researcher Martin Cooper (Cooper, M. (2010)) observed that the number of voice and data connections had doubled every two and a half years since Guglielmo Marconi's initial wireless transmissions in 1895, and it accounts for 32% of yearly growth rate. In the future, the Ericsson Mobility Report predicts a 42 percent annual growth rate in mobile data traffic from 2016 to 2022, which is faster than Cooper's law. Without a doubt, the need for wireless data communication will continue to rise in the near future; For example, video fidelity is always improving, and whole new essential services are on the horizon. All electronic gadgets in a networked world are connected to the Internet. All electronic gadgets are connected to the Internet in today's networked world. However, the main problem here is to improve current wireless communication technologies in order to meet the ever-increasing demand and, as a result, prevent a data traffic congestion. Another significant problem is to meet the growing demand for high quality services. Customers want wireless services to integrate seamlessly with a reliable and always accessible energy grid at all times and in all places. Due to the need to compete with an epidemic rate of traffic growth and provide ubiquitous connection, academia and industry researchers are compelled to use every available resource to develop new revolutionary wireless network technologies. This study confirmed that an in-depth assessment of cellular communication network area throughput was conducted, as well as a solution to fulfil future network demand.

The International Tele-communication Union (ITU) has initiated an official research investigation into 6G technology. The goal is to develop advanced wireless networks and establish self-sustaining systems. The emergence of services and applications such as augmented reality and holographic communications, as well as the transmission of extremely high-definition videos, requires the use of Tera-Hertz (THz) communication as a foundation for future 6G networks. Additionally, 6G aims to offer reduced latency and ultra-high reliability for long-distance communication. The THz band, which spans from 0.1 THz to 10 THz, provides a substantial amount of bandwidth, enabling ultra-high data rates. Many experts anticipate that 6G will deliver comprehensive coverage and unlimited wireless connectivity.

Terahertz (THz) massive multiple-input multiple-output (MIMO) is considered as a promising technology for future 6G network [1]. It can provide tenfold more bandwidth, and compensate for the severe path loss through high-array-gain beams. Nevertheless, traditional hybrid precoding structure in massive MIMO cannot deal with the beam split effect caused by the vary large bandwidth and a very large number of antennas [2], [3]. Specifically, the beam split effect means the beams generated by the traditional frequency-independent phase-shifters (PSs) may split into different physical directions over different subcarriers within the large bandwidth, which results in

a serious array gain loss and thus an achievable sum-rate loss. To solve this problem, we have proposed the delay-phase precoding structure by introducing a time delay network as a new precoding layer, which can mitigate the array gain loss caused by the beam split effect [3].

Considering that the THz channel is quasi-optical with a single dominant path [4], the beam selection based hybrid precoding method, which chooses the beam with the highest array gain for each user, is able to achieve the near-optimal achievable sum-rate [5]. To realize the beam selection, the channel information is essential. However, it is difficult for the base station (BS) to obtain the accurate channel information of large size in THz massive MIMO systems. More seriously due to the narrow width of high-array-gain beams, the optimal beam varies fast due to the user mobility. Hence, traditional channel estimation schemes will result in high training overhead in THz massive MIMO systems [6]. To avoid such high training overhead, the efficient beam tracking schemes are more practical for THz massive MIMO systems [7]–[9].

Terahertz (THz) communication is considered as one of the promising technologies for future 6G wireless communications, since it can provide tens of GHz bandwidth to support ultra-high data rates. However, THz signals suffer from the severe path loss due to the high carrier frequencies. To compensate for the severe path loss, massive multiple-input multiple-output (MIMO), which can generate directional beams with high array gains, is considered promising to be integrated in future THz communications. Nevertheless, the widely considered hybrid precoding structure in massive MIMO [10] cannot deal with the beam split effect caused by the wide bandwidth and a large number of antennas in THz massive MIMO systems [11]. Specifically, the beam split effect can be seen as a serious situation of the widely known beam squint [12], [13], which means that the beams generated by the traditional frequency-independent phase-shifters (PSs) may be totally split into different physical directions over different subcarriers within the large frequency band. Consequently, these beams over different subcarriers cannot be aligned with the target user in a certain direction, which leads to a serious array gain loss and thus an obvious achievable sum-rate loss. To solve this problem, introducing time-delayers into precoding structure, such as true-time-delay array [14]–[16], array-of-sub array structure [17], and delay phase precoding structure [18], is considered to be promising. Thanks to the frequency-dependent phase shifts provided by time-delayers, these precoding structures can significantly mitigate

the array gain loss caused by the beam split effect. To realize precoding, accurate channel information is essential. Generally, the channel information can be obtained through channel estimation. However, because of the large size of channel information, traditional channel estimation schemes will result in an unacceptable channel estimation overhead in THz massive MIMO systems [19]. To avoid such an unacceptable overhead, the beam training scheme is preferred. Instead of estimating full channel information of large size, the beam training scheme directly estimates the physical directions of channel paths [20], which is realized by using directional beams through a training procedure between the base station (BS) and users. Thanks to the quasi-optical characteristic of THz channel [21] and the accurate physical directions obtained by beam training, the beam selection based precoding

method is able to achieve the near-optimal achievable sum rate when users are quasi-static [22]–[24]. Unfortunately, the beam training scheme suffers from a high training overhead when users are moving. Specifically, since the optimal beam of a moving user varies fast due to the narrow beam width, the beam training procedure has to be carried out frequently, and thus results in a high beam training overhead. Therefore, to reduce the beam training overhead for mobile users, an efficient beam tracking scheme is required for practical THz massive MIMO systems [25]. THz communications are currently limited to small-scale applications due to the significant path loss bottleneck. The THz band is utilized in various cutting-edge applications[26]. nevertheless, path loss often poses challenges for THz signals. For example, at 0. THz, a path loss of 110 dB/100 m can occur, making it difficult to achieve desired coverage. Fortunately, the use of a precoding strategy can address the path loss issue without the need to increase transmitter power. This technique allows for the generation of narrow beams with high antenna array gain, effectively mitigating the impact of severe path loss[27].

2.EXISTING SYSTEM

The existing beam tracking schemes can be generally divided into two categories. The first category mainly relies on the user mobility model [25]–[27]. The second category is codebook-based beam tracking, where a training procedure between the BS and the user is carried out to find out the optimal beam from a predefined beam codebook [28]–[30]. For the first category of beam tracking schemes, the key problem is how to model the user mobility. Specifically, [25] assumed that the user mobility satisfies the first-order Gauss- Markov model, and an extended Kalman filter method was proposed to track the optimal beam. To improve the beam tracking accuracy, the user mobility was further formulated as a kinematic model, and a modified unscented Kalman filter was exploited to track the channel angles more accurately [26]. In addition, based on the linear motion model defined by user physical direction and user velocity, a priori-aided beam tracking scheme was proposed in [27]. Nevertheless, this category of beam tracking schemes highly relies on the user mobility model as a priori, which may be inaccurate and cannot be easily obtained, especially in THz massive MIMO systems. The second category

of beam tracking schemes depends on the design of codebook-based beam training algorithms, where each codeword in the codebook determines a directional beam. For instance, [28] searched the optimal beam among a beam codebook containing potential beams through a single-sided exhausted training procedure. To reduce the unacceptable beam training overhead caused by the large codebook size in [27], an adaptive search scheme was proposed by using the hierarchical codebook, which consists of different beam code words with different angular coverage. To further accelerate the beam tracking procedure, an auxiliary beam pair based beam tracking scheme was proposed in [30], where the optimal beam was obtained based on the user received signals of two auxiliary beams generated by two extra RF chains. Note that codebook-based beam tracking schemes have been widely considered in millimeter-wave massive MIMO systems. Although the existing beam tracking schemes above [25]–[27] can achieve the acceptable performance, they are only suitable for narrowband systems with the traditional hybrid precoding structure. In wideband THz massive MIMO systems, since the hybrid precoding structure cannot mitigate the serious beam split effect, these schemes will suffer from a severe performance degradation. Consequently, an efficient wideband beam tracking scheme is essential for wideband THz massive MIMO systems. Recently, several wideband beam tracking or training scheme have been proposed. Specifically, a fast tracking scheme based on frequency-dependent beams generated by true-time-delay array was proposed in [16]. While, due to the large number of antennas, utilizing true-time delay array will introduce unacceptable energy consumption in THz massive MIMO.

3. PROPOSED SYSTEM

We propose a beam zooming based beam tracking scheme to solve the wideband beam tracking problem in THz massive MIMO systems. For the wideband systems, the severe performance loss caused by the beam split effect must be eliminated. Thus, in this paper we consider the delay-phase precoding structure [18], which has been proved to be able to achieve the near-optimal achievable sum-rate performance with acceptable energy consumption in wideband THz massive MIMO systems. The contributions of this paper can be summarized as follows. We reveal the beam zooming mechanism by analyzing the angular coverage of frequency-dependent beams generated by the delay-phase precoding structure. We show that by the elaborate design of time delays, i.e., the frequency-dependent phase shifts, the angular coverage of these beams can be flexibly zoomed to achieve a required angular range. This mechanism to flexibly control the angular coverage, i.e., the degree of beam split effect, enables us to generate multiple beams simultaneously by using only one RF chain, which is impossible for existing schemes.

Based on the beam zooming mechanism, we propose a beam zooming based beam tracking scheme to solve the wideband beam tracking problem. In the proposed scheme, multiple user physical directions are tracked by multiple frequency-dependent beams in each time slot. By leveraging the beam zooming mechanism, the angular coverage of these beams can be flexibly controlled to cover a fraction of the potential variation range of the user physical direction. After the whole variation range of the user physical direction has been tracked, the BS can obtain the optimal beam based on the user received signal power. Unlike traditional beam tracking schemes which usually track only one user physical direction in each time slot, the proposed scheme is able to track multiple user physical directions in each time slot by actively controlling the angular coverage of frequency-dependent beams, i.e., the degree of beam split effect. Thus, the beam training overhead can be significantly reduced.

SYSTEM MODEL:

The wideband THz multi-user mMIMO system is considered. The Base Station use N -antennas to serve K single-antenna users over a band width B , and OFDM with M subcarriers is employed.

A terahertz massive MIMO system is a conventional hybrid precoding. Owing to the drawbacks of the Analog Beamforming and Spatially sparse precoding method, propose a new technique called a DPP. In DPP, we study a THz mMIMO system with conventional hybrid precoding. The BS services an N_t -antenna identical array and N_{RF} is the RF chain. A user with N_r -antenna is provided, as well as N_s data streams were transmitted at the same time ($N_t \gg N_{RF} \geq N_s = N_r$). To appreciate consistent wideband transmission, we accept OFDM with M subcarriers. We familiarize a time-delay (TD) among the traditional analog beamformer as well as the digital precoder [12]–[13]–[14]. Every RF chain being sub-connected to K TD components, which are in turn sub-connections to $P = N_t/K$ conventional frequency independent PS. As a result, the m th subcarrier of signal received may be written as

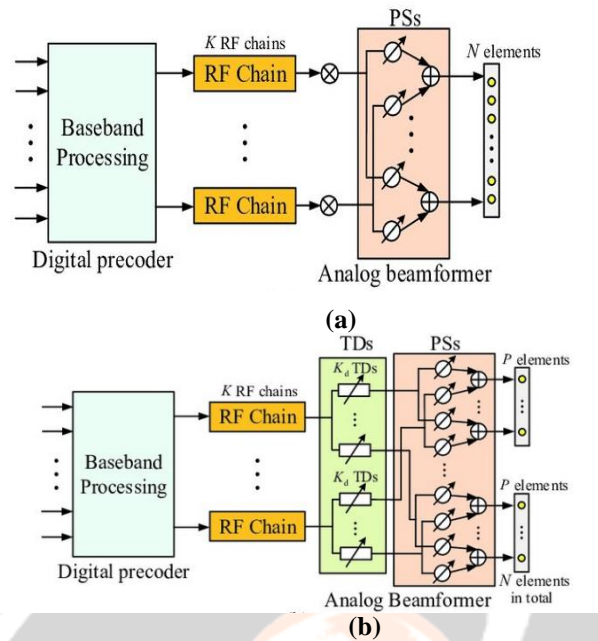

Fig 2: (a) Hybrid precoding structure; (b) Delay phase precoding structure[16].

$$Y_m = \sqrt{\rho} H_m^H A D_m S_m + n_m \tag{1}$$

Where $H_m \in \mathbb{C}^{N_r \times N_t}$ denotes the channel at the m th sub-carrier. $A \in \mathbb{C}^{N_t \times N_{RF}}$ is the analog beamforming provided by the frequency based PSs, D_m is the digital precoder at the m th sub-carrier. We examine the wide band beam based channel model[20] for THz communication. Then, the time-domain channel h_{n_t, n_r} can be represented as

$$h_{n_t, n_r} = \sum_{l=1}^L g_l(t - T_l - (n_r - 1) \frac{d}{c} \sin \theta_l - (n_t - 1) \frac{d}{c} \sin \theta_l) \tag{2}$$

where L is the paths g_l and T_l , denotes the path gain and path delay of the l th path ϕ_l .

A. Beam split Effect

As illustrated in Figure.2, the effect of beam split occurs when the array gain is severely degraded[20]. We start with l th path component, which has a spatial direction $\theta_{l,m}$ in THz mMIMO channel without loss of generalization. Typically, $a_l = A[:, l]$ the beam of the analog beamformer is used on the l th path spatial direction at f_c and $a_l = f_t(\theta_l, c)$

$$|f_t(\theta_l, c) H a_l| = |\eta(a_l, \theta_l, c)| = |f_t(\theta_l, c) f_t(\theta_l, c) H| = 1 \tag{3}$$

As a result of, narrowband systems may have the maximum array gain throughout that bandwidth is $f_m \approx f_c$. As a result, at various subcarriers, the path components have varied spatial direction.

$$\theta_{l,m} = f_m / f_c \theta_{l,m} = \xi_m \theta_{l,m} \tag{4}$$

Where $\xi_m = f_m / f_c$ is the comparative frequency, In THz communications, Based on the problem given above, we suggest a new precoding method for the DPP.

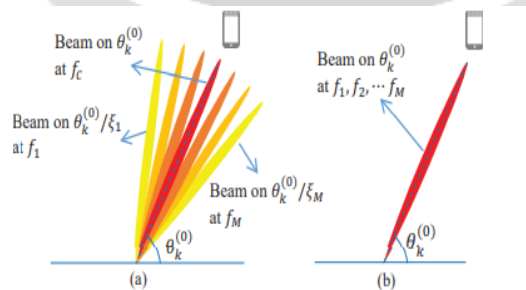

Fig 3. (a) Beam Split effect; (b) Beams generated by the DPP.

A. True time delay based DPP

The frequency-independent beam shape produced by the PSs in the traditional hybrid precoding design would suffer substantial array gain loss as a result of the beam split effect. We'll suggest a precoding architecture called

DPP in this subsection to address this issue Fig. 3 illustrates the comparison with the hybrid precoding architecture.

We investigate the l-th channel route component without losing generality. We now use the frequency based $a_{l,m}$ in lieu of the frequency based a_l to indicate the analog beamform vector created through the Delay Phase Precoding because the TD network can give frequency based phase shifts. The frequency based analog beamform vector $a_{l,m}$, for example, may be written as

$$a_{l,m} = \text{diag}([a_{l,1}, a_{l,2}, a_{l,3}, \dots, a_{l,K}])P_{m,l} \tag{5}$$

where $a_{l,k} \in \mathbb{C}^{1 \times P}$, $k=0,1,2,3,\dots,K$ represents the analog beamform vector concluded through PSs connected to the kth Time Delay elements.

The user may then be covered by the beams across the whole bandwidth, resulting in a gain for the array that is close to ideal. First, we will employ frequency based PS to build a beam pointed in the desired physical direction to fulfil this design objective. that a_l , such as

$$f_l(\theta_l) = [a_{l,1}^T, a_{l,2}^T, \dots, a_{l,K}^T] \tag{6}$$

Then, we use frequency dependence for the direction which the beams $[a_{l,1}^T, a_{l,2}^T, \dots, a_{l,K}^T]$ = $f_l(\theta_l)$ is arranged from $\theta_{l,m}$ to θ_l . In particular, due to the frequency based phase shifts $2f_{m,t,k} = \beta_{l,m} (K+1)$ with $k = 1, 2, 3, \dots, K$, $P_{l,m}$ satisfies

$$P_{l,m} [k] = [1, e^{-j\pi\beta_{l,m}}, e^{-j2\pi\beta_{l,m}}, e^{-j2\pi\beta_{l,m}}, \dots, e^{-j\pi(K+1)\beta_{l,m}}]T \tag{7}$$

To obtain the almost ideal array gain across the full bandwidth, we developed a DPP design, and a new Time Delay network is interposed among the PS network and the RF chains as.

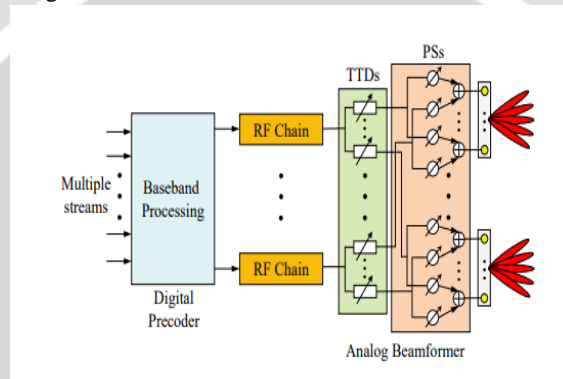

Fig.4: The proposed TTD-DPP structure.

$$Y_m = \sqrt{\rho} H_m^H A_m D_m S_m + n_m \tag{8}$$

where $A_m \in \mathbb{C}^{N_{RF} \times N_t}$ is the analog beamformer with the formation as

$$A_m = [A_{m,1}, A_{m,2}, \dots, A_{m,n}] \tag{9}$$

Here $\text{diag}([a_{l,1}, a_{l,2}, \dots, a_{l,K}])$ indicates the analog beamform and $A_m^{TTD} \in \mathbb{C}^{K N_{RF} \times N_t}$ is the frequency based phase shift fulfilled by the TTD network,

B.BEAM ZOOMING BASED BEAM TRACKING METHOD

The beam codebook generates the prospective beam matched with a certain directions for each codeword. For beam tracking, BS delivers training pilot sequences to every user at various times using distinct code words from the codebook[19].The beamforming vector for the following frame is then chosen from the codeword with the highest received power.

The frame of the kth user is to physical direction is indicated by $\theta^{(0)}_{k,i}$.In general, the angle tracking range may be reduced using information about the user's movement. The method of the standard beam tracking method in[19] utilising the Delay Phase Precoding may be expressed as

$$\theta^{(t)}_{k,i} = \theta^{(0)}_{k,i} - \alpha + (2t - 1)\alpha/T \tag{10}$$

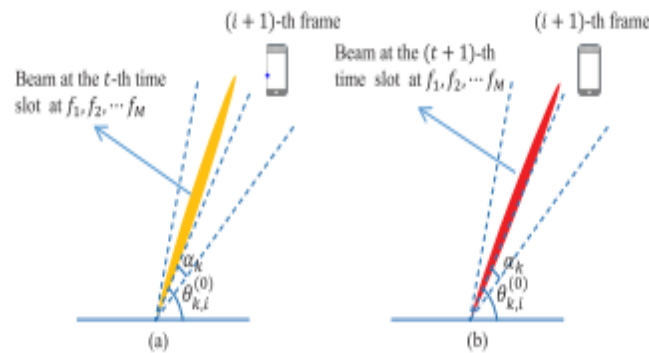

Fig.4.The typical beam tracking scheme [19] adapted to the DPP structure: (a) the beams generated by the DPP structure at the t-th time slot; (b) the beams generated by the DPP structure at the (t + 1)th time slot

In physical directions of the $\theta^{(0)}_{k,i}$, $t = 1, 2, 3, \dots, T$ can covering the tracking ranges of $[\theta^{(0)}_{k,i} - \alpha, \theta^{(0)}_{k,i} + \alpha]$. Then, the BS sends pilot sequence with the beam aligned to the physical direction $\theta^{(0)}_{k,i}$ to the kth user in the tth time slot. The Algorithm 2 is Beam's tracking method to find the physical directions of users $\theta^{(0)}_{k,i}$ for all K users. At 1st the user that will be tracking in the tth time slots are computed in step 1 and step 2, are $\theta^{(0)}_{k,i}$, cen indicates the central direction that will be tracking at the mth sub carrier in the tth time slot as

$$\theta^{(0)}_{k,i} = \theta^{(0)}_{k,i,cen} + (1 - \zeta_1)\alpha/T + 2\zeta_m\zeta_1(\zeta_m - 1)/\zeta_m(\zeta_m - \zeta_1)\alpha/T \quad 11$$

In step 3, a target direction set $\psi_{i+1,k}$ is created by combining all probable users directions that will be monitored throughout T time intervals. To ensure that the whole angle tracking range will be explored, the target direction set is tracked in T time slots once it has been constructed. In the tth time slots, beams that covers the tth fraction of tracking ranges is $[\theta^{(0)}_{k,i+1} - \alpha + (2t-2)\alpha/T, \theta^{(0)}_{k,i+1} - \alpha + 2t\alpha/T]$ are caused by the DPP structure in steps 5-9.

$$\theta^t_k = \theta^{(0)}_{k,i,cen} + (1 - \zeta_1)\alpha/T \quad 12$$

$$S^t_k = P/2(\theta^t_k + 2\zeta_m\zeta_1 \alpha / (\zeta_m - \zeta_1)T) \quad 13$$

Then, in step 7 and 8, when θ^t_k and S^t_k satisfy (15) and (16). The beams generated by $f^t_{k,m} = A^{s,t}_k e^{-j2\pi f_m t^t_k}$, $m=2, \dots, M$, which is corresponding to the target users directions in ψ^{i+1}_k . Based on t^t_k and $A^{s,t}_k$, the tth time slot A^t_m of the analog beamformer is calculated in steps 8 and 9.

In step 10, A^t_m is the analog beamformer as calculated, the Base Station transmits training pilot sequence $q^t_{k,m} \in C^{Q \times 1}$. The pilot sequences of the received signal for K users $Y_{m,t} \in C^{Q \times K}$ at sub-carrier m can be indicated as

$$Y_{m,t} = k_m H_m A^t_m Q^t_m + N^t \quad 14$$

Where $Q^t_m = [Q^t_{1,m}, Q^t_{2,m}, \dots, Q^t_{k,m}]$

Algorithm 2 Proposed Beam Tracking Scheme

inputs: The no. of pilots in each time slot Q ; Physical directions $\theta_{k,i}^0$; Variation range of user Physical directions α_k ;
outputs: Physical directions $\theta_{k,i+1}^0$;

1. $\theta_{k,i, cen}^{-(t)} = \theta_{k,i}^0 - \alpha + \frac{(2t-1)\alpha}{T}$;
2. $\theta_{k,i}^{-(t)} = \theta_{k,i, cen}^{-(t)} + (1 - \zeta_1) \frac{\alpha}{T} + \frac{2\zeta_m \zeta_1 (\zeta_m - 1) \alpha}{\zeta_m (\zeta_m - \zeta_1) T}$;
3. $\psi_k^{t+1} = [\theta_{k,1,i}^{-(1)}, \theta_{k,2,i}^{-(1)}, \dots, \theta_{k,M,i}^{-(1)}, \theta_{k,1,i}^{-(2)}, \theta_{k,2,i}^{-(2)}, \dots, \theta_{k,M,i}^{-(T)}]$
4. for $t \in 1, 2, 3, \dots, T$ do;
5. $\phi_k^t = \theta_{k,i, cen}^{-(t)} + (1 - \zeta_1) \frac{\alpha}{T}$;
6. $S_k^t = \frac{P}{2} \left(\phi_k^t + \frac{2\zeta_m \zeta_1 \alpha}{(\zeta_m - \zeta_1) T} \right)$ for
7. $A_k^{S,t} = \text{diag}(a_p(\phi_k^t) e^{j\pi(P\phi_k^t + 2S_k^t)})$
8. $f_{k,m}^{(t)} = A_k^{S,t} e^{-j2\pi f_m}$
9. $A_m^t = [f_{1,m}^t, f_{2,m}^t, \dots, f_{K,m}^t]$
10. $Y_{m,t} = k_m H_m A_m^t Q_m^t + N^t$
11. end for
12. $\theta_{k,i+1}^0 = \psi_k^{t+1}$
13. return $\theta_{k,i+1}^0$

Simulation & Results:

The performance of different precoding approaches is demonstrated in this section using numerical simulations. The system parameters are shown in Table 1. We analyze the rate performance of DPP, Hybrid Precoding, and Analog Beamforming for $L=4$ and $L=16$ in Figures 5 and 6. The proposed DPP outperforms the other approaches, achieving over 96% performance compared to the benchmark, as depicted in the graph.

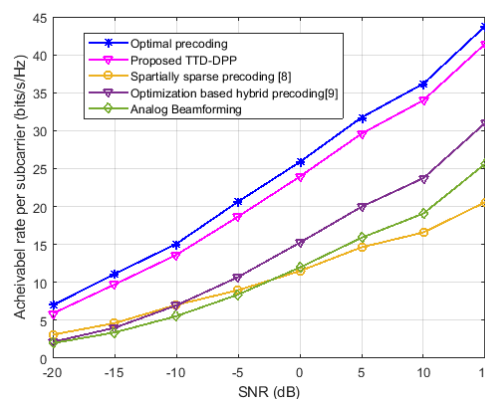

Fig 5: SE versus SNR for different PNRs (L=4)

When $N_s=4$, Fig. 5 and 6 compare the performance of the suggested TTD-DPP and various hybrid precoding methods in terms of the average attainable rate. The spatially sparse precoding in [8], the attainable rate optimisation [9], and the analogue beamforming [12] are examples of existing solutions. We can clearly observe in Figs. 5 and 6 that the beam split effect causes a rate loss of about 50% for the spatially sparse precoding [8]. While the attainable rate loss generated by the beam split effect can be substantially alleviated by the analogue beamforming [12] and achievable rate optimization [9] developed for mm-wave mMIMO systems.

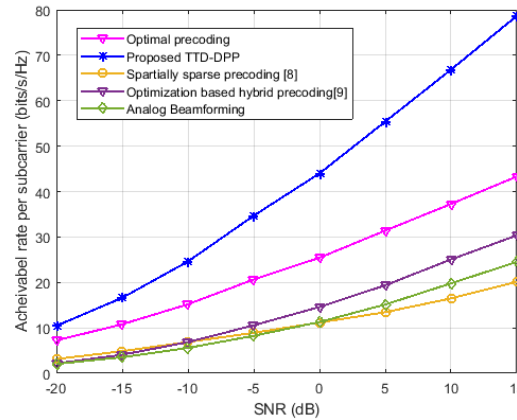

Figure 6: SE versus SNR for different PNRs (L=16)

Fig.7 gives where $N_s=4$, the performance of the average achievable rate K , $SNR=10dB$, to illustrate the outcome of the no.of TTDs K on the proposed TTD-DPP are considered. That the recompense for array gain losses effected within the beam split examine the whole total bandwidth. Observe from Fig. 7 that the performance of the achievable rate for the suggested TTD-DPP improves as K rises and reaches the almost ideal possible rate at $K=16$.

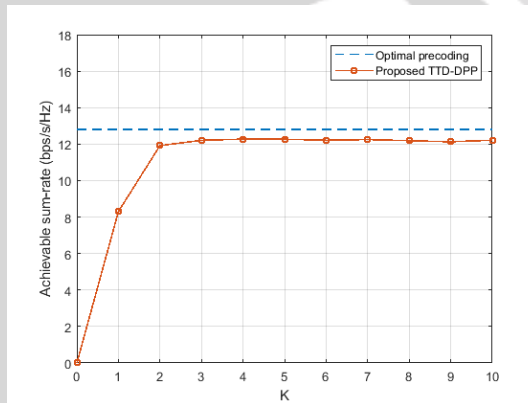

Fig 7: Achievable rate performance versus the No.of TTD's K

Table I: Simulation Parameters for Precoding Techniques

The no. of the BS's antennas(N_t)	256
The no. of the user antennas(N_r)	1,2,4
The no. of channel paths(L)	4,16
The central frequency(f_c)	0.1THz
Bandwidth(B)	30GHz
No. of the subcarriers(M)	128
No.of RFchains(N_{RF})	4
No. of TD elements(K)	16
Transmission SNR(ρ/σ^2)	-20-15dB

In Figure 8, we show the sum-rate performance versus the no.of beam tracked time slot T with k user, the best fully digital Zero Forcing precoding [14], beam selection with suitable physical directions [17] and selection of the beam to the situated on the physical direction tracked by the traditional beam schemes [19] that uses a DPP structure. Physical directions are chosen for the beam using a hybrid precoding structure[8]. We can see from Fig. 8 that the suggested beam tracking system may be used to take advantage of the beam choice to attain near-optimal possible sum-rate with minimal training overhead.

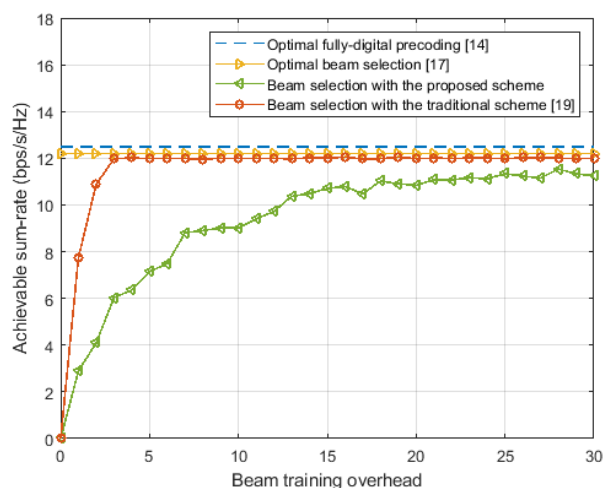

Fig 8: Achievable sum-rate vs beam training over head

Conclusion:

In this research, we have addressed the problem of wideband beam tracing in THz-mMIMO systems and first demonstrated that the beam tracking mechanism can dynamically regulate the angular coverage of the rays caused by the Dealy Phase Precoding, i.e, unlike conventional methods the frequency dependent beams can usually be caused by the RF chain, the suggested approach uses several frequency based beams caused by a single RF chains to track various directions of the user simultaneously, which is achieved by dynamically changing the beam-splitting effect. Compared with the various beam-tracked methods, the suggested method can perfectly tracking the user's mobility with a decreased beams-training overhead of about 95%, as shown by theoretical values and simulation results. Moreover, in the physical directions covered by the proposed approach, the recommended ray tracing method can achieve about 99% of the achievable sum rate, which makes the desirable for massive THz MIMO systems.

REFERENCES:

- [1] C. Liu, W. Feng, Y. Chen, C.-X. Wang, and N. Ge, "Cell-free satellite-UAV networks for 6G wide-area Internet of Things," *IEEE J. Sel. Areas Commun.*, vol. 39, no. 4, pp. 1116–1131, Apr. 2021, doi: 10.1109/JSAC.2020.3018837.
- [2] Y. Zhao, G. Yu, and H. Xu, "6G mobile communication networks: Vision, challenges, and key technologies," *Sci. China Inf. Sci.*, vol. 49, no. 8, pp. 963–987, Aug. 2019, doi: 10.1360/N112019-00033.
- [3] I. F. Akyildiz, C. Han, and S. Nie, "Combating the distance problem in the millimeter wave and terahertz frequency bands," *IEEE Commun. Mag.*, vol. 56, no. 6, pp. 102–108, Jun. 2018, doi: 10.1109/MCOM.2018.1700928.
- [4] L. Yan, C. Han, and J. Yuan, "Hybrid precoding for 6G terahertz communications: Performance evaluation and open problems," in *Proc. 2nd 6G Wireless Summit (6G SUMMIT)*, Mar. 2020, pp. 17–20.
- [5] C. Han, J. M. Jornet, and I. Akyildiz, "Ultra-massive MIMO channel modeling for graphene-enabled terahertz-band communications," in *Proc. IEEE 87th Veh. Technol. Conf. (VTC Spring)*, Jun. 2018, pp. 3–6.
- [6] J. Chen, W. Feng, J. Xing, P. Yang, G. E. Sobelman, D. Lin, and S. Li, "Hybrid beamforming/combining for millimeter wave MIMO: A machine learning approach," *IEEE Trans. Veh. Technol.*, vol. 69, no. 10, pp. 11353–11368, Dec. 2020, doi: 10.1109/TVT.2020.3009746.
- [7] Z. Wei, D. W. K. Ng, and J. Yuan, "NOMA for hybrid mmWave communication systems with beam width control," *IEEE J. Sel. Topics Signal Process.*, vol. 13, no. 3, pp. 567–583, Jun. 2019, doi: 10.1109/JSTSP.2019.2901593
- [8] O. E. Ayach, S. Rajagopal, S. Abu-Surra, Z. Pi, and R. W. Heath, "Spatially sparse precoding in millimeter wave MIMO systems," *IEEE Trans. Wireless Commun.*, vol. 13, no. 3, pp. 1499–1513, Mar. 2014.
- [9] S. Park, A. Alkhateeb, and R. W. Heath, "Dynamic subarrays for hybrid precoding in wideband mmwave MIMO systems," *IEEE Trans. Wireless Commun.*, vol. 16, no. 5, pp. 2907–2920, May 2017.
- [10] O. E. Ayach, S. Rajagopal, S. Abu-Surra, Z. Pi, and R. W. Heath, Jr., "Spatially sparse precoding in millimeter wave MIMO systems," *IEEE Trans. Wireless Commun.*, vol. 13, no. 3, pp. 1499–1513, Mar. 2014.
- [11] X. Gao, L. Dai, S. Zhou, A. M. Sayeed, and L. Hanzo, "Wideband beamspace channel estimation for millimeter-wave MIMO systems relying on lens antenna arrays," *IEEE Trans. Signal Process.*, vol. 67, no. 18, pp. 4809–4824, Sep. 2019.

- [12] B. Wang et al., "Spatial-wideband effect in massive MIMO with application in mmWave systems," *IEEE Commun. Mag.*, vol. 56, no. 12, pp. 134–141, Dec. 2018.
- [13] X. Liu and D. Qiao, "Space-time block coding-based beamforming for beam squint compensation," *IEEE Wireless Commun. Lett.*, vol. 8, no. 1, pp. 241–244, Feb. 2019.
- [14] D. Tse and P. Viswanath, *Fundamentals of Wireless Communication*. Cambridge, U.K.: Cambridge Univ. Press, 2005.
- [15] E. Ghaderi, A. S. Ramani, A. A. Rahimi, D. Heo, S. Shekhar, and S. Gupta, "An integrated discrete-time delay-compensating technique for large-array beamformers," *IEEE Trans. Circuits Syst. I, Reg. Papers*, vol. 66, no. 9, pp. 3296–3306, Sep. 2019.
- [16] V. Boljanovic, H. Yan, E. Ghaderi, D. Heo, S. Gupta, and D. Cabric, "Design of millimeter-wave single-shot beam training for true-time-delay array," in *Proc. IEEE 21st Int. Workshop Signal Process. Adv. Wireless Commun. (SPAWC)*, May 2020, pp. 1–5.
- [17] A. Ali, N. Gonzalez-Prelcic, and R. W. Heath, Jr., "Millimeter wave beam-selection using out-of-band spatial information," *IEEE Trans. Wireless Commun.*, vol. 17, no. 2, pp. 1038–1052, Feb. 2018.
- [18] J. Tan and L. Dai, "Delay-phase precoding for THz massive MIMO with beam split," in *Proc. IEEE Global Commun. Conf. (GLOBECOM)*, Dec. 2019, pp. 1–6.
- [19] PHY/MAC Complete Proposal Specification (TGad D0.1), document IEEE 802.11-10/0433r2, 2010.
- [20] W. Wu, D. Liu, X. Hou, and M. Liu, "Low-complexity beam training for 5G millimeter-wave massive MIMO systems," *IEEE Trans. Veh. Technol.*, vol. 69, no. 1, pp. 361–376, Jan. 2020.
- [21] R. Piesiewicz et al., "Short-range ultra-broadband terahertz communications: Concepts and perspectives," *IEEE Antennas Propag. Mag.*, vol. 49, no. 6, pp. 24–39, Dec. 2007.
- [22] A. Ali, N. Gonzalez-Prelcic, and R. W. Heath, Jr., "Millimeter wave beam-selection using out-of-band spatial information," *IEEE Trans. Wireless Commun.*, vol. 17, no. 2, pp. 1038–1052, Feb. 2018.
- [23] Y. Wang, A. Klautau, M. Ribero, A. C. K. Soong, and R. W. Heath, Jr., "MmWave vehicular beam selection with situational awareness using machine learning," *IEEE Access*, vol. 7, pp. 87479–87493, Jun. 2019.
- [24] X. Gao, L. Dai, Z. Chen, Z. Wang, and Z. Zhang, "Nearoptimal beam selection for beamspace mmWave massive MIMO systems," *IEEE Commun. Lett.*, vol. 20, no. 5, pp. 1054–1057, May 2016.
- [25] S. Jayaprakasam, X. Ma, J. W. Choi, and S. Kim, "Robust beam-tracking for mmWave mobile communications," *IEEE Commun. Lett.*, vol. 21, no. 12, pp. 2654–2657, Dec. 2017.
- [26] J. Zhao, F. Gao, W. Jia, S. Zhang, S. Jin, and H. Lin, "Angle domain hybrid precoding and channel tracking for millimeter wave massive MIMO systems," *IEEE Trans. Wireless Commun.*, vol. 16, no. 10, pp. 6868–6880, Oct. 2017.
- [27] X. Gao, L. Dai, Y. Zhang, T. Xie, X. Dai, and Z. Wang, "Fast channel tracking for terahertz beamspace massive MIMO systems," *IEEE Trans. Veh. Technol.*, vol. 66, no. 7, pp. 5689–5696, Jul. 2017.