

Case Study on Automobile Clutch Plate Juddering

Faheem Haider¹, Achal W Adbaile²

Student Dept. of Mechanical Engineering,
Jhulelal Institute of Technology, Nagpur, Maharashtra

ABSTRACT

The coupling of two working parts, for example two shaft, in such a way as to permit connection or disconnection at will without the necessity of bringing both parts to rest, and when connected to transmit the required amount of power without sign is known as Clutch and or, the friction or hydraulic actuated mechanism used for coupling two shafts or similar parts, one or which drives and the other of when is driven by the Clutch.

Clutch plate assembly has three principal components i.e. Flywheel, Clutch plate and Pressure Plate. The device used is the Clutch which transmits the rotary motion of the engine to the transmission, which required by the driver and located between the engine and the gear box and which it connects and disconnects the two units smoothly without shock.

As per the theory of the Clutch, first assumption is used in case of problems involving power absorption by friction. Second assumption is used in case of problems involving power transmission by friction between the surfaces.

Key Words: Axial Load, Clutch plate, Clutch plate wearing, Clutch Slippage, Excessive vehicle weight Torque converter, Flywheel, Manual transmission, etc.

1. INTRODUCTION:

I.C. engine do not develop high starting torque, it must be therefore, disconnected from the power train (gear box) and allowed to run without load until it develops enough torque to overcome inertia of the vehicle, when starting rest.

Theory of Clutch Plate:

r_1 = outer radius of the friction plate.

r_2 = inner radius of the friction plate.

p = intensity of pressure.

μ = coefficient of friction, w = total axial load.

Therefore, consider an elementary ring of radius $[r]$, width $[dr]$, area of this ring will be $2\pi r dr$. Axial load on this ring will be $2\pi r p \cdot dr$.

r_1

$$\text{Total axial load } w = \int 2 \pi r \cdot p \cdot dr \dots\dots(1)$$

r_2

And total frictional torque $T = \int_1^{r_2} (2 \mu \pi .rp. dr) \times r$

r_2

or, $T = \int_1^{r_2} 2 \mu \pi .r^2.rp. dr) \times r \dots\dots\dots(2)$

From the above equations (1) and (2), can be solved on the basis of following assumptions:

1. The distribution of pressure is uniform,
2. The wear is uniform.

Fig 1(a) distribution of pressure

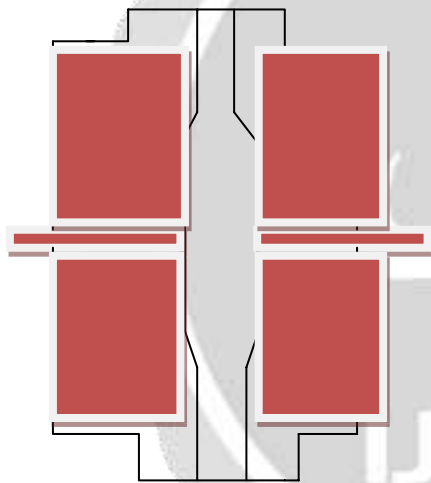
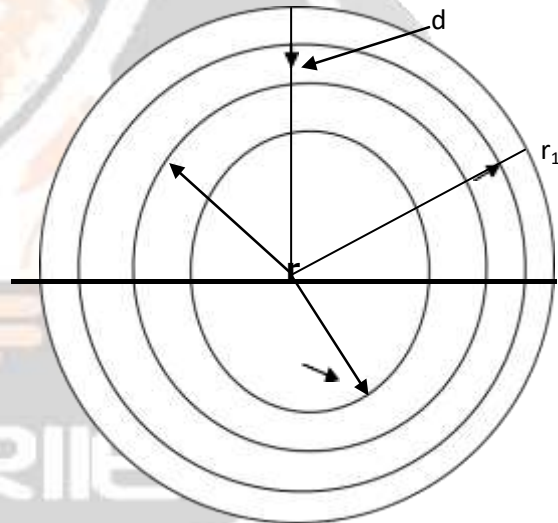

Fig:1(b) Uniform Wear



2. LITERATURE REVIEW:

Now a day, there are two drive train arrangements in common use the following:

1. Front engine rear wheel drive,
2. Front engine front wheel drive.

However, we know that the above two systems, the clutch plate is located in between the engine and the transmission systems.

Two basic types of clutches are the coil spring clutch and diaphragm clutch. The difference between them is in the type of spring.

Fig 2(a): Power Train for a Rear-Wheel drive car with a manual transmission:

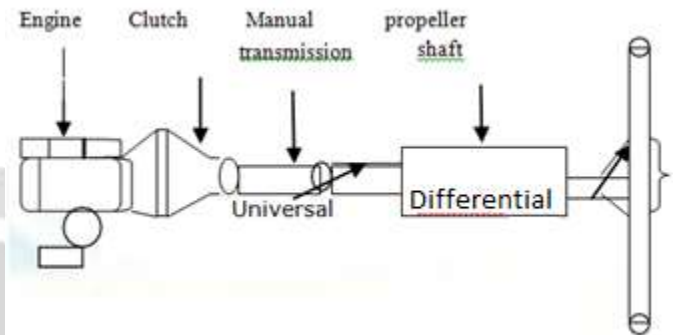

Clutch Slippage is very noticeable during acceleration. It is extremely hard on the clutch facing and mating surface of the flywheel and pressure plate. The slippage clutch generates excessive heat. As a result, the clutch facing wear rapidly and may char and burn. When the flywheel face and pressure plate wear, they may groove, crack and score. The heat in the pressure plate can cause the springs to lose their tension, which makes the situation worse.

As per the theory of clutch plate, intensity of pressure acting on the flat surfaces may be assumed uniform at the various radii, because of the fit between the two surfaces being perfect. But the rate of wear of the surfaces does not only depend on the intensity of pressure but also on the rubbing velocity between the surfaces. Since the rubbing velocity is directly proportional to r , the rate of wear $\propto pr$. Hence if rate of wear is assumed to be constant:

$$Pr = \text{constant} = C$$

First assumption is used in case of problems involving power absorption by friction. Second assumption is used in case of problem involving power transmission by friction between the surfaces.

Here, considering the uniform rate of wear for clutch which transmits power by friction, i.e. $pr = C$

$$= 2\pi C \int_{r_2}^{r_1} dr$$

$$\therefore W = 2\pi C (r_1 - r_2) \dots\dots (3)$$

And, $T = \int_{r_2}^{r_1} 2\pi \mu r^2 \cdot p \cdot dr$

$$= 2\pi \mu C \int_{r_2}^{r_1} r \cdot dr$$

$$\therefore T = \pi \mu C (r_1^2 - r_2^2) \dots\dots(4)$$

Also, $T = \frac{1}{2} \mu W (r_1 + r_2) \dots (5)$

For a Single Plate Clutch having a pair of contact surfaces.

$$T = 2 \pi \mu C (r_1^2 - r_2^2)$$

$$= \pi W ((r_1 + r_2)$$

For multiple clutch having n_a pair of constant surfaces.

$$T = n_a \cdot \pi \mu C (r_1^2 - r_2^2)$$

$$= n_a \cdot \mu w (r_1 + r_2 / 2)$$

And, $n_a = (n-1)$

Where, n = total number of plate with an active driving surface on both driving and driven members.

3. METHODOLOGY:

Aim: Problem in Clutch Plate Juddering:

- a) Vehicle Model: S-Cross Smart Hybrid Zeta
- b) Engine No. D13A-5788487.
- c) Chassis No.MA3FNEB1S00226858
- d) Complain Reported: Clutch
- e) Plate Juddering.
- f) Kms: 17,425 kms.
- g) Observation:
 - Clutch plate free play: Found OK at 30 mm.
 - Clutch Disc: Oil socked in the clutch facing both side.
 - Assy. Clutch Disc: Make – Gujarat Selco.
 - Pressure Plate (make clutch auto): Machine surface of the pressure plate has been found OK.
 - Oil seal ring: Contact at the lip of the oil seal was found uniform (make – swastika) and presumed that oil seal spring not holding rigidly on propeller shaft and oil seepage through the oil seal. Etc.

Corrective action Taken:

Fitted new assy. Clutch Disc and Gear box front and with top oil seal cover and found OK.

From the above, the advantage of the clutch is that the normal force acting on the contact surfaces and in this case a large than the axial force , as compared to the single plate clutch in which the normal force acting on the contact surfaces is equal to the axial force.

Refereeing the above problems, consider an elementary ring of radius r with radial width dr and which parallel to conical surface is dw .

The area of this ring:
 $= 2\pi r dw$.

$$=2\pi r.dr/\sin\theta$$

$$\text{Normal load on ring } dp = p \cdot 2\pi r \frac{dr}{\sin\theta}$$

$$\text{Axial load on ring } dw = dp \sin\theta$$

$$= p \cdot 2\pi r dr$$

$$\text{Total axial load } W = \int_{r_2}^{r_1} p \cdot 2\pi r dr$$

$$= \int_{r_2}^{r_1} 2\pi C dr$$

$$= 2\pi C (r_1 - r_2)$$

$$\text{Total torque about the axis,}$$

$$= \int_{r_2}^{r_1} u dp \cdot r$$

$$= \int_{r_2}^{r_1} \mu p \cdot 2\pi r^2 \frac{dr}{\sin\theta}$$

$$\frac{2\mu\pi}{\sin\theta} \int_{r_2}^{r_1} p r^2 \cdot dr$$

$$= 2\mu\pi / \sin\theta \int_{r_2}^{r_1} r, dr$$

$$= \pi\mu C / \sin\theta (r_1^2 - r_2^2)$$

$$= \frac{\mu(r_1+r_2)w}{2\sin\theta}$$

4. RESULT AND DISCUSSION:

A- The main functions of clutch:

1. To start the engine and warm up.
2. To facilitate to engage gear to start the vehicle from rest. Disconnect power to gear box for assay shifting of gear. Therefore, the noise and damage to the gear is avoided.
3. Disconnecting drive from the engine to stop the vehicle after application of brake, etc.
4. Single plate clutch is now being widely used in cars, trucks and tract respectively. It is consists of flywheel, clutch plate or driven plate, pressure plate assembly, pilot bearing, clutch shaft, thrust springs, clutch fork, carbon thrust bearing, clutch pedal, driving studs, etc.

B - Single plate clutch working:

1. Engagement:

The clutch plate is located in between the flywheel and pressure plate with the help of pressure or thrust spring. The drive takes places from the flywheel face to the clutch plate and is passed through gear box. The driver must leave the clutch pedal slowly so that called engagement.

2. Disengagement:

While the driver released the foot from the clutch pedal, the pressure plate is pushed away by the clutch fork acting on the clutch sleeve, and this position is called disengagement.

3. Clutch Plate Free play:

figure 4(a): Single Plate Clutch.

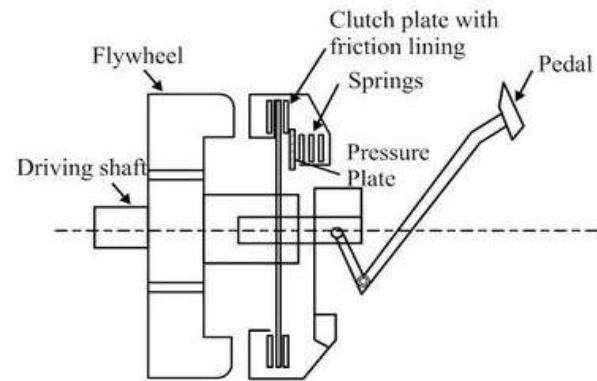

A clearance of about 3 mm is kept between the withdrawal sleeve or release bearing and the clutch fork. This results in a clutch pedal free play of 30 mm. For example, a single plate clutch is to have a maximum capacity of 76 H.P. at 1800 rpm. The Clutch facing has a coefficient of friction of 0.4 and permissible of 2.11 kg/cm², supposed uniform. The clutch is engaged through 12 springs. Determine the diameter of the clutch facing, 17 the inner diameter is 0.7 times the outer. Find also the spring force of each spring when the clutch is engaged. The following is answer:

$$\begin{aligned} \text{Torque} &= \frac{H.P \times 4500}{2\pi N} \\ &= \frac{76 \times 4500}{2\pi \times 1800} = 30.2 \text{ kg.m} \\ &= 3020 \text{ kg.cm} \end{aligned}$$

$$\begin{aligned} T &= \pi \mu C (r_2^2 - r_1^2) \times 2 \\ 3020 &= 0.4 \times \pi \times 2.11 \times r_2 [(r_1^2) - (0.7)^2 r_1^2] \times 2 \\ 3020 &= 0.4\pi \times 2.11 \times 0.7 r_1^3 [1 - 0.49] \times 2 \end{aligned}$$

$$\begin{aligned} r_1^3 &= \frac{3020}{4\pi \times 2.11 \times 0.7 \times 0.51 \times 15} \\ &= 1600 \end{aligned}$$

$$\therefore r_1 = 11.7 \text{ cm}$$

$$\text{And, } r_2 = 8.19 \text{ cm}$$

Hence, outer dia. = 23.4 cm , Inner dia = 16.38 cm

$$\begin{aligned} \text{Total axial force} &= 2\pi C (r_1 - r_2) \\ &= 2\pi \times 2.11 \times r_2 (r_1 - r_2) \\ &= 2\pi \times 2.11 \times 8.19 (11.7 - 8.19) \\ &= 381 \text{ kg.} \end{aligned}$$

$$\begin{aligned} \text{Force of each spring} &= \frac{381}{12} \\ &= 31.75 \text{ kg} \end{aligned}$$

5. TYPE OF DATA

Maruti heavy vehicle used in coil spring type clutch. The coil spring clutch has a series of coil springs set in circle and the following: 310 mm diameter (Coil spring type):

A. Clutch Disc Assembly:

- (a) Diameter of Driven Plate (D): 310 mm
- (b) Frictional Areas (both sides) : 1030 cm².

B. Thickness of clutch Disc: (A).

- (a) Full Load: 10.8 ± 0.3 mm.
- (b) Free Load : 11.6 ± 0.5 mm
- (c) Clutch Lining: 2.2 mm.
- (d) Dumper spring : 8

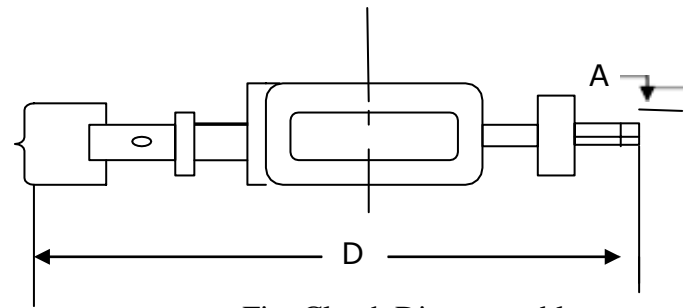

Fig: Clutch Disc assembly

C. Pressure Plate assembly:

- a) Length of pressure plate springs 73.00 mm
- b) Disc Special friction: 10.8 ± 0.3 mm
- c) Clutch length: 80 ± 0.0 to 0.5 mm
- d) Free play of clutch pedal: 35 to 40 mm
- e) Pressure plate cover: casting.
- f) Total length of release lever: 113 mm.

D. Probable Cause:

- ❖ No Clutch Pedal free Play: Free play adjusted up to 35 – 40 mm, if release bearing defective, need to replace new one.
- ❖ Clutch Lining Damage: Need to refit new clutch plate.
- ❖ Oil in lining: Replace the gearbox oil seal due to leakage or refit new clutch lining.
- ❖ Axial Force of pressure plate: Refit new pressure plate.
- ❖ Defective of release bearing: Adjust up to highest length
- ❖ Excessive vehicle weight: Loading as per norms.

6. CONCLUSION:

Clutch facing are mad out of fiber asbestos molded with the help resin. Sometimes, fine copper is also mixed with asbestos during the molding process so as to give facing a little extra strength. In most of the vehicles these facing are joined with the clutch plate with the help of copper or aluminum rivets. Under these circumstances, facing cannot be replaced and the complete clutch plate has to be replaced in case these are found won out.

The advantage of the cone clutch is that the normal force acting on the contact surfaces in this case is larger than the axial force, as compared to the simple single plate clutch in which the normal force acting on the contact surfaces is equal to the axial force. The over and above, requirements of clutch plate the following aspects:

- ❖ It should be easily disengaged and engaged without jerks,
- ❖ Heat developed during operation should be dissipated.
- ❖ Need to dynamically balanced, etc.

7. REFERENCES:

Basic Auto motive engineering by Prof. C.P. Nakra, India.
Automotive Design problem by K M Agrawal, India.
Service Manual of Brakes India.
Service Manual of Maruti.
Automotive Service Business, a book by Dr. Porag Kalita,

8. DEFINITION/ ACRONYMS /ABBREVIATION:

Definition:

Clutch fork: the “Y” shaped clutch lever used for throwing out the clutch.

Clutch Plate adjustment: Adjusting the linkage between the bottom of clutch pedal and the outer end of the throw out yoke lever to provide the proper amount release when the clutch pedal is depressed.

Clutch Vibration Dampener: A flexible power transmitting unit between the driven clutch springs. Plate and its hub, Sometimes the dampener may be of rubber, but more frequently it is in the form of coil springs.

Clutch Facing: the clutch lining of friction material attached to the driven clutch plate.

Acronyms:

Fluid Coupling: A type of clutch arrangement between two working parts, one of which drives the other by means of fluid.

Friction Disk: The angle that the resultant force makes to the normal to the surface over which a body is sliding when friction is present.

Abbreviation:

H.P. = Horse Power
mm = millimeter
rpm = revolution per minute.