

Construction and Commercial Use of PKL Cell

K.A.Khan¹ and A K M Obaydullah²

1- Department of Physics, Jagannath University, Dhaka, Bangladesh
E-mail:kakhan01@yahoo.com

2- Instructor, Upazilla Resource Center, Primary and Mass Education Ministry, Bangladesh
E-mail:obayd77@gmail.com

ABSTRACT

Pathor Kuchi leaf is known as a medicinal leaf from ancient time. Because, it has a great medicinal value. It is used for different kinds of diseases like dysentery, Cholera, Diarrhea, typhoid, kidney diseases etc. In West Bengal, India there is no alternative way about PathorKuchi leaf for focal medicine. People are using this leaf as a focal medicine there. But now a days it is using to generate electricity for low and medium power production. Generally, Zn and Cu metals is used as an electrode and extract of the PKL juice is used as an electrolyte. To enhance the power of the PKL electricity some secondary salt is used. Copper Sulfate (CuSO_4) is one of the important and popular secondary salt for PKL power production. Some Parameters like Load Current, Short Circuit Current, Load Voltage, Open Circuit Voltage, Capacity of the PKL Cell, Voltage Regulation of the Cell, Efficiency of the Cell and Internal Resistance of the Cell Have been studied for immerge depth of the electrodes. The cost of this Power system for practical applications have also been studied. Energy is one of the most essential resources of the present world. We can not imagine the civilization without energy specially electrical energy. In broader sense we can divide electric energy in two types, one is non-renewable energy and the other is renewable energy. Due to the drawbacks of non-renewable energy and advantages of renewable energy, the use of renewable energy is increasing day by day. Eventually new sources and technology is coming out. One of the new technologies of renewable source is the production of electricity from Pathor Kuchi Leaf (PKL), the scientific name of that is Bryophyllum Pinnatum. We can easily produce electricity from PKL by immersing a Zinc and a Copper plate in to the juice of PKL. This system produces theoretically 1.1 volts per cell. So if we need higher voltage or higher current we need to combine more cells to get the desire power. To keep it in mind, In this paper a new approaches is presented to get more power from per cell of the PKL system which is out of traditional cell concept for per cell power. Most of the results have been tabulated and graphically discussed.

Keyword: PKL, Construction, Commercial, Electricity, Biomass Energy

1.Objectives

- i. To generate electricity from an innovative method for the betterment of the mankind.
- ii. To disseminate this innovative technology to rural people where grid electricity is absent.
- iii. To popularize this innovative technology to the rural complex area of Bangladesh where grid electricity is still a dream.
- iv. To reduce environmental pollution using this innovative technology.
- v. To commercialize the PKL power in the society

2.Introduction

Constructing an affordable cost, environment friendly simplified electrical energy source with Pathor Kuchi Leaf for power electrifications which will significantly upgrade the life style of 1.275 billion people in Bangladesh. 1.5 billion people in the world still lack access to electricity-well over of one fifth of the world's population. Some 85% (1.275 billion) of these people live in rural areas, mainly in Sub-Saharan Africa and

South Asia (Bangladesh, India, Sri Lanka, Pakistan, Nepal and Bhutan). This innovative technology will meet essential requirements as lighting, telecommunication as well as information access. The studies on *Bryophyllum Pinnatum* (locally called Pathor Kuchi) showed that its pH is 4.8 with 10% water and 4.2 without water and Titratable is 0.88%. Investigations showed that Electricity prepared by *B. pinnatum* (*Bryophyllum pinnatum*) leaf juice/Sap has significant performance and comparatively cheap with respect to another Renewable Energy Sources and the conventional gas based Electricity. Electrodes are put into the *Bryophyllum Pinnatum* Leaf (BPL) or Pathor Kuchi Leaf (PKL) sap and they Produce substantially sufficient amount of electricity to power energy consumed Electronics and electrical appliances. A cell is an arrangement of two electrodes in an electrolytic solution capable of producing electricity. In a cell electricity is produced due to the chemical reaction within the cell between electrodes and electrolyte. How much voltage will be produce in a cell depends mainly on the electrodes and electrolyte used. So for a particular set of electrodes this voltage is defined in the Table of Standard Reduction Potentials. As per the table half reaction potential for copper is 0.34 Volts and the half reaction for zinc is -0.76 Volts. So if we consider a cell with Cu and Zn electrode than the cell potential will be $0.34 - (-0.76) = 1.1$ Volts. So if we need to produce 6 volts we need to connect six cells in series. Again if one cell can generate 0.5 ampere current and we need 2.0 ampere current then four Cells will be connected in Parallel. So for a power of 12 watt with 6 volts from this type of cell we need to connect six cells in series to get 6 volts and to get 12 watt power we need 2 ampere current to flow through the circuit. Hence, It will be needed to connect 4 sets of 6 cells in parallel combination. For higher power we need to undergo same series parallel combination of cells, which makes the system more complex and lower the efficiency of the system.

3. Effect of combination of PKL cells

The power produced by PKL cell is low. Moreover it has a high internal resistance. Due to this high internal resistance the voltage drop as well as power loss within the cell is high. On the other hand we need to undergo series connection of several cells to get the desire voltage level from the system. When we connect several cells in series it also adds the internal resistances of individual cells. So the internal resistances of the combination of cells multiples and become higher. This high value of internal resistance is a very big barrier to get high power. For an example, let us consider a PKL cell with a cell voltage is 1.0 volt with a internal resistance 0.6Ω . To use this PKL power for a 6 volt system we need to connect 6 PKL cells in series. Also let us consider the load needs 0.5 Ampere current. Figure 1 shows the connection for 6 PKL cells in series.

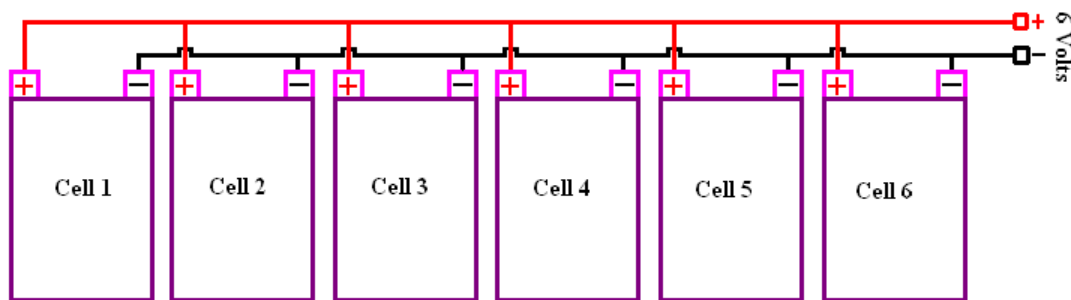

Figure 1: Six cells are connected in series for an output of six volts.

From the figure we can find that the total internal resistance of the PKL system is $0.6 \times 6 = 3.6 \Omega$. If the system draws a current of 0.5 Ampere, the voltage due to internal resistance will be $0.5 \times 3.6 = 1.8$ Volts. Therefore, $6.0 - 1.8 = 4.2$ volts will be available at the output of the PKL system. Again if we draw 0.4 Ampere current from the PKL system the voltage drop due to internal resistance will be $0.4 \times 3.6 = 1.44$ volts and the output voltage will be $6.0 - 1.44 = 4.56$ volts. It indicates that the voltage regulation of the system will improved if we draw less current. When the current is 0.5 ampere the voltage regulation will be $[(6.0 - 4.2) \div 4.2] \% = 43 \%$. Again when the current is 0.4 ampere the voltage regulation will be $[(6.0 - 4.56) \div 4.56] \% = 32 \%$. All these figures are very high values for a power supply system. For a reliable power supply system output voltage should be keep stable and the voltage regulation should be as low as possible. For a stable system if we consider the maximum allowable voltage regulation for the PKL system will be 5 % then the above system should keep a output voltage 5.7 volts and in this condition it could be suitable for supply only 0.08 ampere current. Therefore the high value of internal resistance of the PKL cell is the big barrier to draw the required power from it.

4. Producing higher power avoiding the higher value of internal resistance.

We know the power is the product of voltage and current. If we want big power we need to increase the voltage or current or both voltage and current. For an example if we want to generate a 3.0 watt power from the system we can generate it keeping the voltage 6 voltage and producing a current 0.5 ampere. So the product will be $6.0 \times 0.5 = 3.0$ Watt. Again we can produce the same 3.0 watt power producing a voltage of 12 volts and drawing a

0.25 ampere current. Because, in this case, the product of voltage and current will be again $12 \times 0.25 = 3.0$ watt. In brief if we produce more voltage we need to draw lower current for the same power output. Again the internal resistance is the barrier on the way of flow of current only. Therefore if we draw less current the voltage drop due to internal resistance will be less. Hence it will increase the voltage regulation and hence system stability. For example in the first case when we produce 6.0 volts with a current of 0.5 ampere the voltage regulation will be 43 %. But in the second case when we produce 12 volts with a current of 0.25 ampere the voltage regulation will be 8 % only considering the same internal resistance 3.6Ω in both the cases.

5. Proposed Concept beyond the Cell Concept

In a Voltaic cell two half cell is connected with a salt bridge. Electric potential developed between each half cell produce based on the reaction of electrode and electrolyte. How much potential will be generated in a half cell depends on the electrodes and electrolyte used and for a particular set of electrode and electrolyte each half cell potential is listed in a **Table of Standard Reduction Potentials**. A short version of such table is given below

Table 1: Standard Electrode Potential

Reduction Half-reaction	Standard Potential
$Fe^{3+}(aq) + e^{-} \rightarrow Fe^{2+}(aq)$	+0.77
$I_2(l) + 2e^{-} \rightarrow 2I^{-}(aq)$	+0.54
$Cu^{2+}(aq) + 2e^{-} \rightarrow Cu(s)$	+0.34
$Sn^{4+}(aq) + 2e^{-} \rightarrow Sn^{2+}(aq)$	+0.15
$S(s) + 2H^{+}(aq) + 2e^{-} \rightarrow H_2S(g)$	+0.14
$2H^{+}(aq) + 2e^{-} \rightarrow H_2(g)$	0.00
$Sn^{2+}(aq) + 2e^{-} \rightarrow Sn(s)$	-0.14
$V^{3+}(aq) + e^{-} \rightarrow V^{2+}(aq)$	-0.26
$Fe^{2+}(aq) + 2e^{-} \rightarrow Fe(s)$	-0.44
$Cr^{3+}(aq) + 3e^{-} \rightarrow Cr(s)$	-0.74
$Zn^{2+}(aq) + 2e^{-} \rightarrow Zn(s)$	-0.76
$Mn^{2+}(aq) + 2e^{-} \rightarrow Mn(s)$	-1.18

As per the table half reaction potential for copper is 0.34 Volts and the half reaction for zinc is -0.76 Volts. So if we consider a cell with Cu and Zn electrode than the cell potential will be $0.34 - (-0.76) = 1.1$ Volts. In PKL cell we need not to use separate half cell connected with salt bridge rather two half cell keep in the same container. The concept of salt bridge is absent in PKL cell. But the PKL produce the potential difference between the anode and cathode as per the standard reduction potential. It also follows the Nernst equation. We know to produce the higher voltage we need to connect required number of cells in series. The connection is as shown in figure 2.

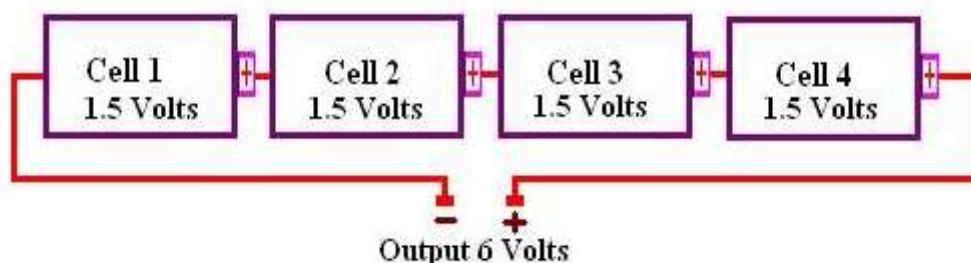

Figure 2: Cells are connected in series to provide higher output voltage.

For system voltage, $V_{System} = V_{Cell 1} + V_{Cell 2} + V_{Cell 3} + \dots + V_{Cell n}$

i.e.
$$V_{System} = \sum_{n=1}^{x=1} V_{Cell x}$$

For system current, $I_{System} = I_{Cell 1} = I_{Cell 2} = I_{Cell 3} = \dots = I_{Cell n}$

Based on this concept following arrangement can be made in a same cell to produce higher voltage.

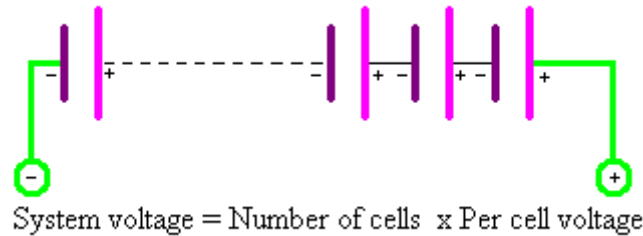

Figure 3: Series connection of cells.

A practical arrangement of the proposed concept is shown in figure 3 below:

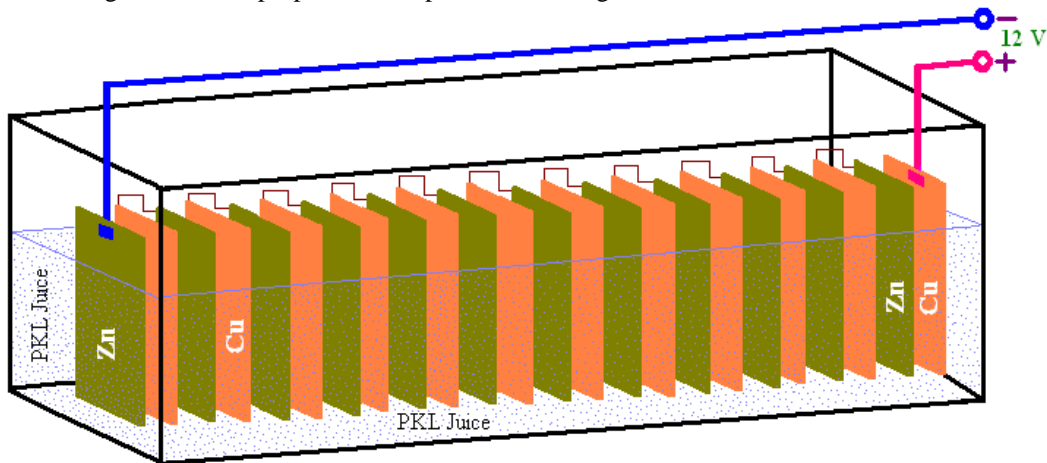

Figure 4: Proposed concept of producing higher voltage from a single cell.



Figure.5: An experimental set-up for the Commercial Use of PKL cell

Here Zinc plates and copper plates are put in sequence in the same container within the PKL juice. A Zinc plate and a Copper plate form a micro cell. These two plates are connected physically. One such cell produces 1.1 volts. In this figure there are 12 such micro cells placed in the same container. There is no physical connection between the micro cells. But PKL juice itself acting as the connecting media between micro cells. Thus this combination will produce $1.1 \times 12 = 13.2$ volts. We can use this combination to get the desired voltage from a one cell. Practically let us consider this voltage is 12 V.

6. Cost of PKL electric system compare to PKL Home System

Cost of 20kw Diesel generator system = 13 Lac
 Cost of 20kw SPV System = $20000w \times 250Tk = 50$ Lac
 Cost of 20kw PKL System = 1.25 Lac

7. Advantages of the proposed concept

Some of the advantages of the proposed concept are listed below:

1. It can produce higher voltage in a single cell.
2. For the desired voltage output no need to go for separate cell connected externally.
3. No need to separate the cells.
4. Reduce the internal connection and hence reduce the internal resistance and loss.

5. We can get desired output increasing the area of plate.
6. No attendance is required.
7. Maintenance is easy
8. Primary Cost is 1/3 rd of the Solar system
9. Any person can operate this power system
10. Even a handicapped person can operate this power system
11. In the night time its performance increased
12. In the rainy and other all seasons its performances are same

8. Further Study

The following studies have to be done for this new concept:

1. Internal resistance of this new PKL system with comparison to the traditional system.
2. Voltage Regulation of this new PKL system with comparison to the traditional system.
3. Energy efficiency of this new PKL system with comparison to the traditional system.
4. Voltage efficiency of this new PKL system with comparison to the traditional system.
5. Current efficiency of this new PKL system with comparison to the traditional system.
6. Pulse Performance of this new PKL system with comparison to the traditional system.
7. Self discharge characteristics of this new PKL system with comparison to the traditional system.
8. Discharge characteristics with load of this new PKL system with comparison to the traditional system.
9. Capacity the cell of this new PKL system with comparison to the traditional system.
10. Temperature effect of this new PKL system with comparison to the traditional system.
11. Variation of $[Cu^{2+}]$ ions with the Variation of concentration of PKL juice of this new PKL system with comparison to the traditional system.
12. Variation of $[Cu^{2+}]$ ions with the Variation of concentration of PKL juice during self discharge of this new PKL system with comparison to the traditional system.
13. Variation of $[Cu^{2+}]$ ions with the Variation of concentration of PKL juice during discharge Characteristics with load of this new PKL system with load with comparison to the traditional system.
14. Variation of $[Cu^{2+}]$ ions with the Variation of distance between two plates for the constant PKL juice concentration of this new PKL system with comparison to the traditional system.
15. Variation of $[Cu^{2+}]$ ions with the Variation of distance between two plates for the constant PKL juice concentration during self discharge of this new PKL system with comparison to the traditional system.
16. Variation of $[Cu^{2+}]$ ions with the Variation of distance between two plates for the constant PKL juice concentration during discharge characteristics with load of this new PKL system with comparison to the traditional system.
17. Variation of $[Zn^{2+}]$ ions with the Variation of concentration of PKL juice of this new PKL system with comparison to the traditional system.
18. Variation of $[Zn^{2+}]$ ions with the Variation of concentration of PKL juice during self discharge of this new PKL system with comparison to the traditional system.
19. Variation of $[Zn^{2+}]$ ions with the Variation of concentration of PKL juice during discharge Characteristics with load of this new PKL system with load with comparison to the traditional system.
20. Variation of $[Zn^{2+}]$ ions with the Variation of distance between two plates for the constant PKL juice concentration of this new PKL system with comparison to the traditional system.
21. Variation of $[Zn^{2+}]$ ions with the Variation of distance between two plates for the constant PKL juice concentration during self discharge of this new PKL system with comparison to the traditional system.
22. Variation of $[Zn^{2+}]$ ions with the Variation of distance between two plates for the constant PKL juice concentration during discharge characteristics with load of this new PKL system with comparison to the traditional system.
23. Nanoparticles (NPs) have to be produced using PKL to enhance the Longevity of PKL power system
24. More R&D has to be done on Dynamic method for better performance of the PKL system

9. Conclusion

It is shown that the performance of PKL power is better in the night time whereas the performance of the solar system decreased in the night time that is almost zero at night. For Solar system it needs battery at night for storing the power, which needs extra money. The performance decreased at night for solar photovoltaic system whereas the performance of the PKL power increased at night. The performance decreased during rainy season for solar photovoltaic system whereas the performance of the PKL power is same. This work is totally different from traditional Cell or battery concept. Experimentally we have to find and compare the following parameters: Internal resistance of the cell, Voltage regulation of the cell, Energy efficiency of the cell, Pulse performance of

the cell, Discharge characteristics with load of the cell, Self discharge characteristics of the cell, Temperature effect of the cell and Life cycle of the cell. This work will be the guide line for future work.

10. Acknowledgement

The authors are grateful to the PKL electricity research group named Mohammad Al Mamun, Dr. M. A. Latif, Md. Mahfuz Alam, Md. Abdullah Al Momin, Md. Moiful Alam, Mr. Rashed, Mr. Mamun, Dr. Md. Sajjad Hossain, Md. Asrafusjaman Rubel, Dr. Fakrul Islam, Bapy Guh, Md. Afzol Hossain, Dr. Jesmin Sultana and Prof. Dr. Mesbah Uddin Ahmed for their valuable suggestions and whole hearted cooperation during research work

11. References:

- [1] K. A. Khan and M. M. Alam, "Performance of PKL (Pathor Kuchi Leaf) Electricity and its Uses in Bangladesh", *Int. J. SOC. Dev. Inf. Syst.* 1(1): 15-20, January 2010.
- [2] K. A. Khan, M. H. Bakshi and A. A. Mahmud, "Bryophyllum Pinnatum leaf (BPL) is an eternal source of renewable electrical energy for future world", *American Journal of Physical Chemistry* 2014;3(5):77-83, published online, November 10, 2014 (<http://www.sciencepublishinggroup.com/j/ajpc>) doi:10.11648/j.ajpc.20140305.15, ISSN:2327-2430 (Print); ISSN: 2327-2449(Online), 2014.
- [3] K. A. Khan, "Electricity Generation form Pathor Kuchi Leaf (Bryophyllum pinnatum)", *Int. J. Sustain. Agril. Tech.* 5(4): 146-152, July 2009.
- [4] K. A. Khan and Md. Eyashir Arafat, "Development of Portable PKL (Pathor Kuchi Leaf) Lantern", *Int. J. SOC. Dev. Inf. Syst.* 1(1): 15-20 January 2010.
- [5] K. A. Khan and Ranen Bosu, "Performance study on PKL Electricity for Using DC Fan", *Int. J. SOC. Dev. Inf. Syst.* 1(1): 27-30, January 2010
- [6] K. A. Khan and Md. Imran Hossain, "PKL Electricity for Switching on the Television and Radio", *Int. J. SOC. Dev. Inf. Syst.* 1(1): 31-36, January 2010
- [7] Shuva Paul, K. A. Khan, Kazi Ahad Islam, Baishakhi Islam and Musa Ali Reza, "Modeling of a Biomass Energy based (BPL) Generating Power Plant and its features in comparison with other generating Plants", *IPCBE* vol. 44 (2012) @ (2012) IACSIT Press, Singapore DOI: 10.7763/ IPCBEE. 2012. V44. 3
- [8] K. A. Khan, Shuva Paul, Md. Adibullah, Md. Farhat Alam, Syed Muhammad Sifat, Md. Rashed Yousef, "Performance Analysis of BPL/PKL Electricity module", *International Journal of Scientific & Engineering Research* Volume 4, Issue-3, March-2013 1 ISSN 2229-5518
- [9] K. A. Khan, Shuva Paul, Asif Zobayer, Shiekh Saif Hossain, A Study on Solar Photovoltaic Conversion, *International journal of Scientific and Engineering Research*, Volume-4, Issue-3, March-2013, ISSN 2229-5518, 2013
- [10] Tania Akter, M H Bhuiyan, Kamrul Alam Khan and M H Khan, "Impact of photo electrode thickness and annealing temperature on natural dye sensitized solar cell", Published in the journal of Elsevier. Ms. Ref. No.: SETA-D-16-00324R2, 2017
- [11] K. A. Khan, Inventors, Electricity Generation form Pathor Kuchi Leaf (PKL), Publication date 2008/12/31, Patent number BD 1004907
- [12] K. A. Khan, Technical note Copper oxide coatings for use in a linear solar Fresnel reflecting concentrating collector, Publication date 1999/8/1, *Journal Renewable energy*, Volume 17, Issue 4, Pages 603-608, Publisher – Pergamon.
- [13] K. A. Khan, Shuva Paul, A analytical study on Electrochemistry for PKL (Pathor Kuchi Leaf) electricity generation system, Publication date 2013/5/21, Conference- Energytech, 2013 IEEE, Pages 1-6, Publisher, IEEE.
- [14] T. A. Ruhane, M. Tauhidul Islam, Md. Saifur Rahaman, M. M. H. Bhuiyan, Jahid M. M. Islam, M. K. Newaz, K. A. Khan, Mubarak A. Khan, Photo current enhancement of natural dye sensitized solar cell by optimizing dye extraction and its loading period, Published in the journal of Elsevier: *Optik - International Journal for Light and Electron Optics*, 2017.
- [15] K. A. Khan, M S Alam, M A Mamun, M A Saime & M M Kamal, Studies on electrochemistry for Pathor Kuchi Leaf Power System, Published in the *Journal of Bangladesh J. Agric. And Environ.* 12(1): 37-42, June 2016
- [16] Mehedi Hasan, Lovelu Hassan, Sunjida Haque, Mizanur Rahman, Kamrul Alam Khan, A Study to Analyze the Self-Discharge Characteristics of Bryophyllum Pinnatum Leaf Fueled BPL Test Cell, Published in the *Journal of IJRET*, Vol-6 Iss-12, Dec-2017
- [17] J. Sultana, K. A. Khan, and M. U. Ahmed. "Electricity Generation From Pathor Kuchi Leaf (PKL) (Bryophyllum Pinnatum)." *J. Asiat Soc. Bangladesh Sci.*, 2011, Vol. 37(4): P 167-179
- [18] M. Hasan, S. Haque and K. A. Khan, "An Experimental Study on the Coulombic Efficiency of

- Bryophyllum pinnatum Leaf Generated BPL Cell”, IJARIE, ISSN(O)-2395-4396, Vol-2, Issue-1, 2016
- [19] Khan, Kamrul Alam, Akhlaqur Rahman, Md Siddikur Rahman, Aniqah Tahsin, Kazi Md Jubyer, and Shuva Paul. "Performance analysis of electrical parameters of PKL electricity (An experimental analysis on discharge rates, capacity & discharge time, pulse performance and cycle life & deep discharge of Pathor Kuchi Leaf (PKL) electricity cell)." In *Innovative Smart Grid Technologies-Asia (ISGT-Asia)*, 2016 IEEE, pp. 540-544. IEEE, 2016.
- [20] Khan, Md Kamrul Alam, Shuva Paul, Md Siddikur Rahman, Ripon Kumar Kundu, Md Mahmudul Hasan, Mohammad Moniruzzaman, and Mohammad Al Mamun. "A study of performance analysis of PKL electricity generation parameters:(An experimental analysis on voltage regulation, capacity and energy efficiency of pathor kuchi leaf (PKL) electricity cell)." In *Power India International Conference (PIICON)*, 2016 IEEE 7th, pp. 1-6. IEEE, 2016.
- [21] MM Hasan, MKA Khan, MNR Khan and MZ Islam, "Sustainable Electricity Generation at the Coastal Areas and the Islands of Bangladesh Using Biomass Resources", *City University Journal*, Vol. 02, Issue. 01, P. 09-13, 2016.
- [22] M Hasan and KA Khan, "Bryophyllum pinnatum Leaf Fueled Cell: An Alternate Way of Supplying Electricity at the Off-grid Areas in Bangladesh" in *Proceedings of 4th International Conference on the Developments in Renewable Energy Technology [ICDRET 2016]*, P. 01, 2016. DOI: 10.1109/ICDRET.2016.7421522
- [23] M Hasan, KA Khan, MA Mamun, "An Estimation of the Extractable Electrical Energy from Bryophyllum pinnatum Leaf", *American International Journal of Research in Science, Technology, Engineering & Mathematics (AIJRSTEM)*, Vol. 01, Issue. 19, P. 100-106, 2017.
- [24] K.A.Khan, Lovelu Hassan, A K M Obaydullah, S.M. Azharul Islam, M.A. Mamun, Tanjila Akter, Mehedi Hasan, Md. Shamsul Alam, M. Ibrahim, M Mizanur Rahman and M. Shahjahan," Bioelectricity: A new approach to provide the electrical power from vegetative and fruits at off-grid region, accepted in the journal of *Microsystem Technologies of Springer*, manuscript number: MITE-D-17-00623R2, 2018, DOI: 10.1007/s00542-018-38083
- [25] Md. Kamrul Alam Khan, Md. Siddikur Rahman, Muhammad Najebul Ahmed, Kaushik Nandan Saha, Shuva Paul, Investigation on parameters performance of Zn/Cu electrodes of PKL, AVL, Tomato and Lemon juice based electrochemical cells: A comparative study, published in the journal of *Electrical Information and Communication Technology (EICT)*, 2017 3rd International Conference on IEEE Xplore: 01 February 2018, DOI: 10.1109/EICT.2017.8275150, IEEE, Khulna, Bangladesh, Bangladesh, 7-9 Dec. 2017.
- [26] Md. Afzol Hossain, Md. Kamrul Alam Khan, Md. Emran Quayum,"Performance development of bio-voltaic cell from arum leaf extract electrolytes using zn/cu electrodes and investigation of their electrochemical performance", *International Journal of Advances in Science Engineering and Technology*, ISSN: 2321-9009, Vol-5, Iss-4, Spl. Issue-1, Nov-2017
- [27] K.A. Khan, M. A. Wadud, A K M Obaydullah and M.A. Mamun, PKL (Bryophyllum Pinnatum) electricity for practical utilization, IJARIE-ISSN(O)-2395-4396, Vol-4, Issue-1, Page: 957-966
- [28] K. A. Khan, A. Rahman, M. S. Rahman, A. Tahsin, K. M. Jubyer, and S. Paul, "Performance analysis of electrical parameters of PKL electricity (An experimental analysis on discharge rates, capacity & discharge time, pulse performance and cycle life & deep discharge of PathorKuchi Leaf (PKL) electricity cell)," In *Innovative Smart Grid Technologies-Asia (ISGT-Asia)*, 2016 IEEE, pp. 540-544. IEEE, 2016.
- [29] M. K. A. Khan, S. Paul, M. S. Rahman, R. K. Kundu, M. M. Hasan, M. Moniruzzaman, and M. A. Mamun, "A study of performance analysis of PKL electricity generation parameters:(An experimental analysis on voltage regulation, capacity and energy efficiency of pathorkuchi leaf (PKL) electricity cell)," In *Power India International Conference (PIICON)*, 2016 IEEE 7th, pp. 1-6. IEEE, 2016.
- [30] M. K. A. Khan, M. S. Rahman, T. Das, M. N. Ahmed, K. N. Saha, and S. Paul, "Investigation on Parameters performance of Zn/Cu Electrodes of PKL, AVL, Tomato and Lemon juice based Electrochemical Cells: A Comparative Study," In *Electrical Information and Communication Technology (EICT)*, 2015 3rd International Conference on, pp. 1-6. IEEE, 2017.
- [31] M.M. Haque, A.K.M.A. Ullah, M.N.L Khan, A.K.M.F. F. Kibria and K.A.Khan,"Phyto-synthesis of MnO₂ Nanoparticles for generating electricity," In the International conference on Physics-2018, Venue-Department of Physics, University of Dhaka, Dhaka-1000, Bangladesh, Organizer-Bangladesh Physical Society(BPS, 08-10 March, 2018.
- [32] Lovelu Hasan, Mehedi Hasan, Kamrul Alam Khan and S.M. Azharul Islam, "SEM Analysis of Electrodes and measurement of ionic pressure by AAS data to identify and compare the characteristics between different bio-fuel based electrochemical cell, " In the International conference on Physics-2018, Venue-Department of Physics, University of Dhaka, Dhaka-1000, Bangladesh, Organizer-Bangladesh Physical Society(BPS, 08-10 March, 2018.
- [33] Mehedi Hasan and Kamrul Alam Khan, "Identification of BPL Cell Parameters to Optimize the Output Performance for the Off-grid Electricity Production," In the International conference on Physics-2018, Venue-

Department of Physics, University of Dhaka, Dhaka-1000, Bangladesh, Organizer-Bangladesh Physical Society(BPS, 08-10 March, 2018).

[34] K A Khan, M.S.Bhuyan, M. A. Mamun, M. Ibrahim, Lovelu Hassan and M A Wadud, "Organic electricity from Zn/Cu-PKL electrochemical cell", Published in the Souvenir of First International Conference of Contemporary Advances in Innovative & Information Technology (ICCAIAT) 2018, organized by KEI, In collaboration with Computer Society of India (CSI), Division-IV (Communication). The proceedings consented to be published in AISC Series of Springer, 2018

[35] M.K.A.Khan, A K M Obaydullah, M.A. Wadud and M Afzol Hossain, "Bi-Product from Bioelectricity", IJARIE-ISSN(O)-2395-4396, Volume-....., Issue-....., Page-...., 2018

[36] M.K.A.Khan and A K M Obaydullah, "Construction and Commercial Use of PKL Cell", IJARIE-ISSN(O)-2395-4396, Volume-...., Issue-...., Page-, 2018

[36] K. Alam Khan, "Copper Oxide Coating for use in Linear Solar Fresnel Reflecting Concentrating Collector", Renewable Energy, An International Journal, Elsevier, WREN (World Renewable Energy Network), UK, RE: 12.97/859, 1998

[37] S. J. Hassan & K. A. Khan, "Determination of Optimum Tilt angles of Photovoltaic panels in Dhaka, Bangladesh." International J. Eng. Trach 4 (3): 139-142, December 2007. Webiste : www. Gscience. Net , 2007

[38] S.J.Hassan & K. A. Khan, "Design, Fabrication and performance study of Bucket type solar candle machine", International J. Eng. Trach 4 (3), December 2007. Webiste : www. Gscience. Net, 2007

[39] M. A. Hamid Khan & Dr. Md. Kamrul Alam Khan, "Nuclear science and Applications. Vol. 14, No. 11 June 2005", Nuclear science and Applications. Vol. 14, No. 11 June 2005

[40] Dr. Md. Kamrul Alam Khan, "Prospect of Solar Energy for Food Supply in Bangladesh", Bangladesh Journal of Scientific and Industrial Research BJSIR, 37 (1-4), January-December, 2002

[41] B.K.Sen, K.A. Khan, M.A. Hamid Khan, M.A. Awal, "Studies on Optical & thermal properties of black copper solar selective coating on copper substance", Jahang. Phys. Stud. Vol. 9, 2001, Department of Physics, Jahangirnagar University, Savar, Dhaka, Bangladesh, 2001

[42] M.N. Ahsan, B.K. Sen, K.A. Khan & M.A. Hamid Khan, "Performance of a Low Cost Built-in-storage Solar Water Heater", Nuclear Science and Applications vol. 8 No. 1-2, Dec 1999

[43] A.J. Khan, Kamrul Alam Khan, Z.H. Mahmood & M.Hossain, "Performance of an Intermittently Tracked Linear Solar Fresnel Reflecting Concentrator", The Dhaka University studies, part B (science) vol. 39 No. 2 July, 1991

[44] K.A. Khan, A.J. Khan & K.S. Rabbani, "Design & performance studies of a Linear Fresnel Reflecting Solar Concentrator-Receiver System", Bangladesh J.Sci. Res. 16 (2): 143-146, 1998

[45] Md. Kamrul Alam Khan, "Studies on Electricity Generation from Stone Chips Plant (*Bryophyllum pinnatum*)", International J.Eng. Tech 5(4): 393-397, December 2008