

# Control of Wind Driven DFIG

Abhishek Singatkar<sup>#1</sup>, Saransh Patankar<sup>#2</sup>, Arbaj Shaikh<sup>#3</sup>, Ujwal Mayde<sup>#4</sup>

<sup>#</sup>Department Of Electrical Engineering, SKNSITS Lonavala, Maharashtra, India

## ABSTRACT

Energy is one of the most prominent factors in shaping the civilization of today. Under consideration for non-conventional energy source wind energy has turned out to be a leading source of energy. In recent years there has been a significant global commitment to develop a clean and economical alternative sustainable power source especially from wind. In this field of development wound rotor induction generator has seen considerable success. One scheme of wound rotor induction generator is realized when a converter cascade is used between the slip rings terminals and the utility grid to control the rotor power. This configuration is called Doubly Fed Induction Generator (DFIG). In this paper analyses the control strategy of grid connected to a DFIG. The paper implements a control technique to mitigate the voltage sag generated due to various fault. Finally the paper concludes with an inference of the voltage profile generated by a DFIG and a vivid study of various parameters at varied conditions.

**Keywords**— Doubly-fed induction generator (DFIG), protection, Wind power generation, voltage sag, fault.

## I. INTRODUCTION

The installed capacity of wind power in Europe reached approximately 33,600 MW until the end of 2004. The demand for connecting large-scale wind parks to the power grid is still on the rise. The increasing size of wind turbine and Wind Park resulted in new interconnection rules or grid codes. Today, there is a need to control wind power, both in active and reactive power, and to be able to stay connected with the grid when grid faults happen. The doubly fed induction generator (DFIG) has the largest world market share of wind turbine concepts since the year 2002 [1], because of its ability to provide variable speed operation and independent active and reactive power control in a cost-effective way. As DFIG's stator is directly connected with ac grid, it has poor low-voltage ride through (LVRT) capability due to the poorly damped flux oscillations during grid voltage dip. Many studies have been conducted on the LVRT capability of DFIG [3]–[6], [9], with most of them focused on the behavior and protection of DFIG under symmetrical fault. During the symmetrical fault, transient over current in the rotor is identified as the most severe LVRT problem of the DFIG, because the rotor-side voltage source converter (VSC) is very sensitive to thermal overload. Thus, the active crowbar protection is designed to short-circuit the rotor under symmetrical grid voltage dip, both to protect the rotor-side VSC and to damp out the oscillations faster. In reality, however, unsymmetrical fault happens much more frequently than symmetrical fault. Furthermore, it is identified that the unbalanced voltages can occur in a weak power grid even during normal operation [7], [8], [15]. Under the unbalanced grid voltage, the most severe operation problem of DFIG may not be the transient over current, but the large electric torque pulsation that causes wear and tear of the gearbox, and large voltage ripple in the dc link of back to- back VSC that may decrease the lifetime of the dc capacitance. Literatures [10], [11] define the instantaneous active and reactive power that can be used to design and operate the grid connected VSC under unbalanced grid situations [12]–[13]. Literatures [14], [15] on the control system of DFIG under unbalanced grid voltage condition. In [15], the grid VSC was controlled as a STATCOM and supplied reactive power to compensate the unbalanced grid voltage. A detailed model of DFIG is made in MATLAB/Simulink. Simulation results prove the effectiveness of the proposed control system.

## II. DOUBLY FED INDUCTION GENERATOR

The working of DFIG is based on the principle of induction generator. It has multiphase wound rotor and a multiphase slip ring assembly with brushes for accessing rotor winding. The rotor windings are connected to the grid via slip rings and a back to back voltage source converter that controls both the rotor and grid currents (hence acting as a control system). By adjusting the converter's parameters it is possible to control the active and reactive power fed to the grid independently of the generators turning speed, giving it a distinct advantage over other conventional power generators. Fig.1 shows a schematic representation of a DFIG setup:

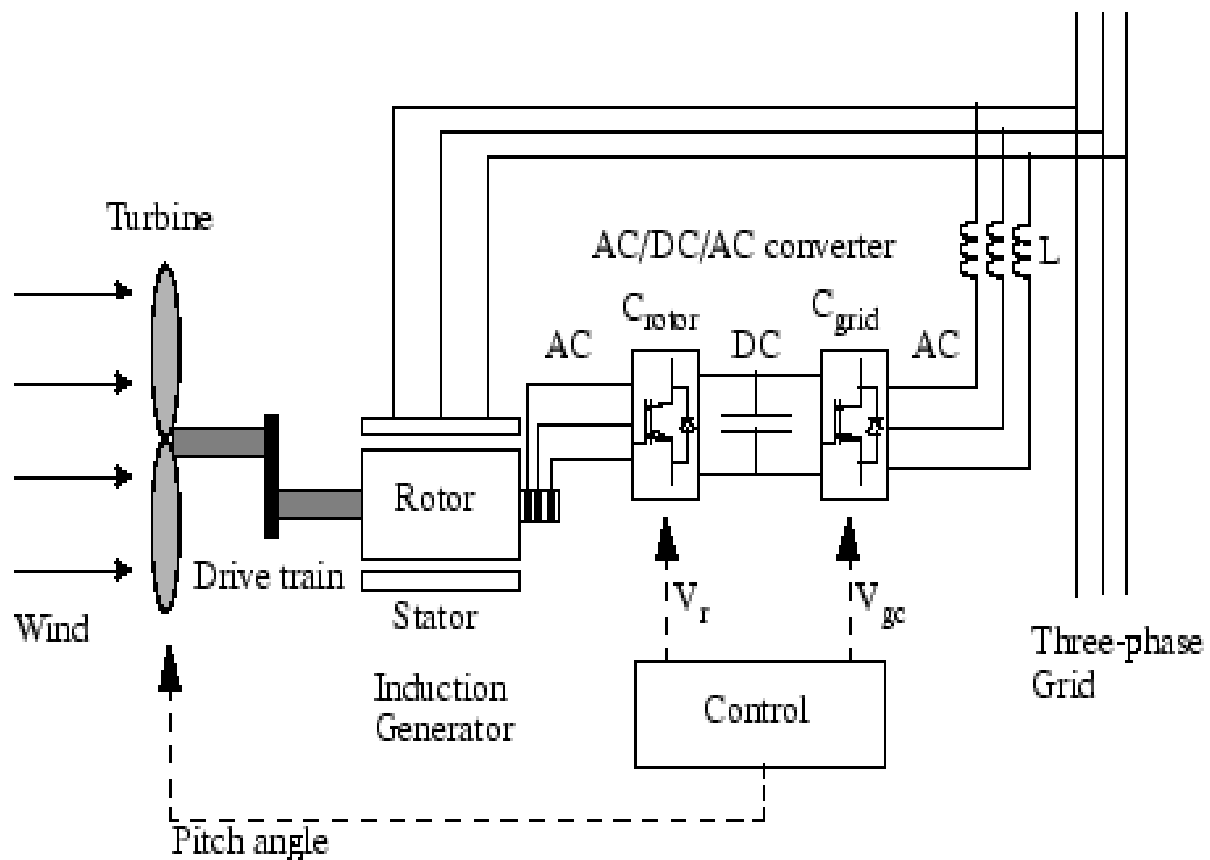

Fig1. DFIG model

### III. VOLTAGE SAG

A voltage sag as defined by IEEE Standards 1159-1995, is a decrease in the RMS voltage at the power frequency for duration from .5 cycles to 1 minute. The measurement of the voltage sag is defined as the percentage of the nominal voltage. Example: Voltage sag to 60% is equal to 60% of nominal voltage i.e. 288 volt for a 480 volt system.

### IV. WIND TURBINE CONCEPTS

The three most important currently applied wind turbine concepts are: [4]

1. A constant speed wind turbine, which consists of a directly grid coupled squirrel cage induction generator. The wind turbine rotor is coupled to the generator through a gearbox. The power extracted from the wind is limited using the stall effect. This means that the rotor is designed in such a way that its efficiency decreases in high wind speeds, thus preventing the mechanical power extracted from the wind to become too large. In most cases, no active control systems are used to this end.
2. A variable speed wind turbine with doubly fed (wound rotor) induction generator. The rotor winding is fed using a back-to-back voltage source converter. Like in the first concept, the wind turbine rotor is coupled to the generator through a gearbox. In high wind speeds, the power extracted from the wind can be limited by pitching the rotor blades.
3. A variable speed wind turbine with a direct drive synchronous generator. The synchronous generator can have a wound rotor or be excited using permanent magnets. It is grid coupled through a back-to-back voltage source converter or a diode rectifier and voltage source converter. The synchronous generator is a low speed multi pole generator, therefore no gearbox is needed. Like in the second concept, the power extracted from the wind is limited by pitching the rotor blades in high wind speeds. The concepts are depicted in figure 2

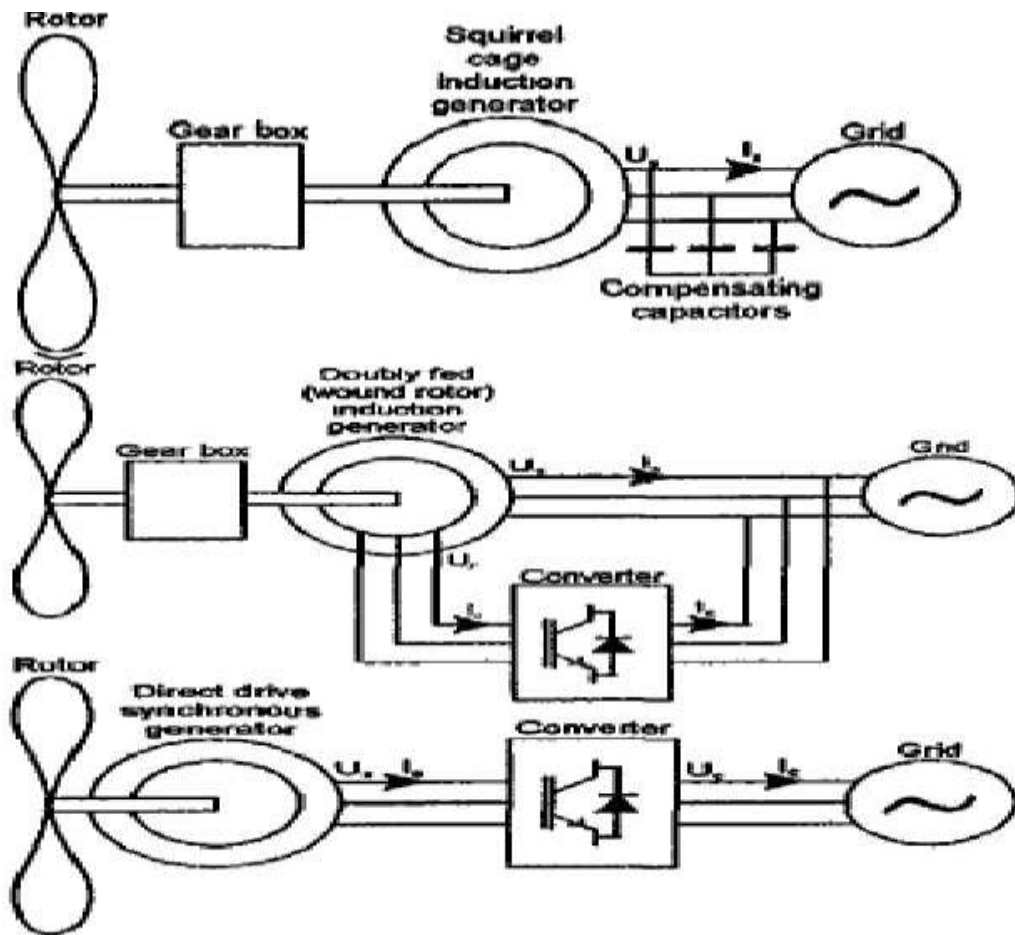

Fig2. Widely used contemporary wind turbine concepts

### V. DFIG BEHAVIOUR DURING FAULT CONDITION

Voltage sag (also the word voltage dip is used) is a sudden reduction of the voltage at a point in the electrical system, which lasts for half a cycle to 1 min. Depending on the type of fault, the magnitudes of the voltage dips of each phase might be equal or unequal. The magnitude of voltage sag at a certain point in the system depends mainly on the type of the fault and the distance of the fault. [2] The voltage dip can cause high induced voltages or currents in the rotor circuit. The high current might destroy the converter, if nothing is done to protect it. [5]. Fig 3 shows the behaviour of DFIG during fault condition.

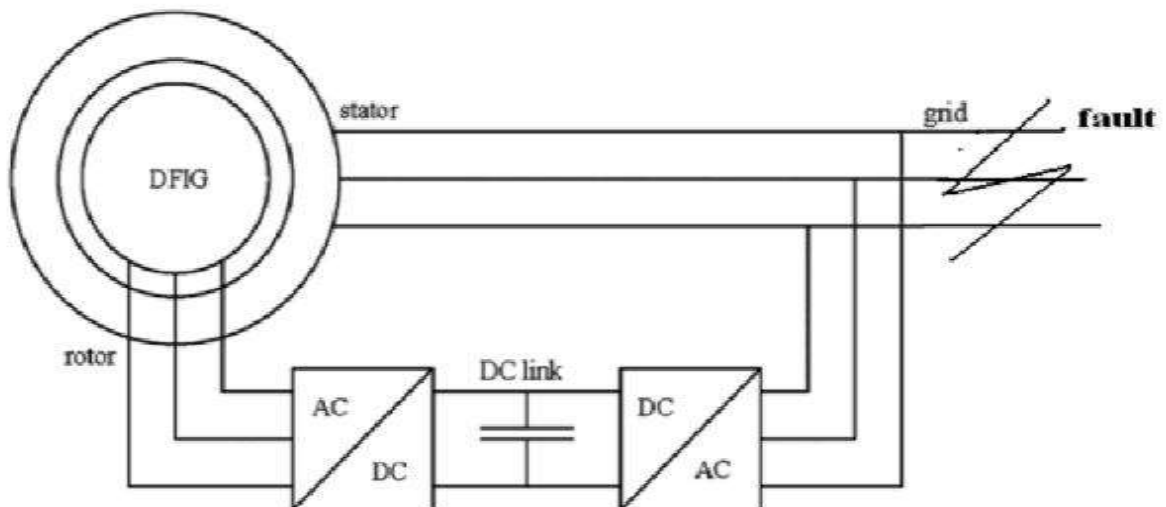
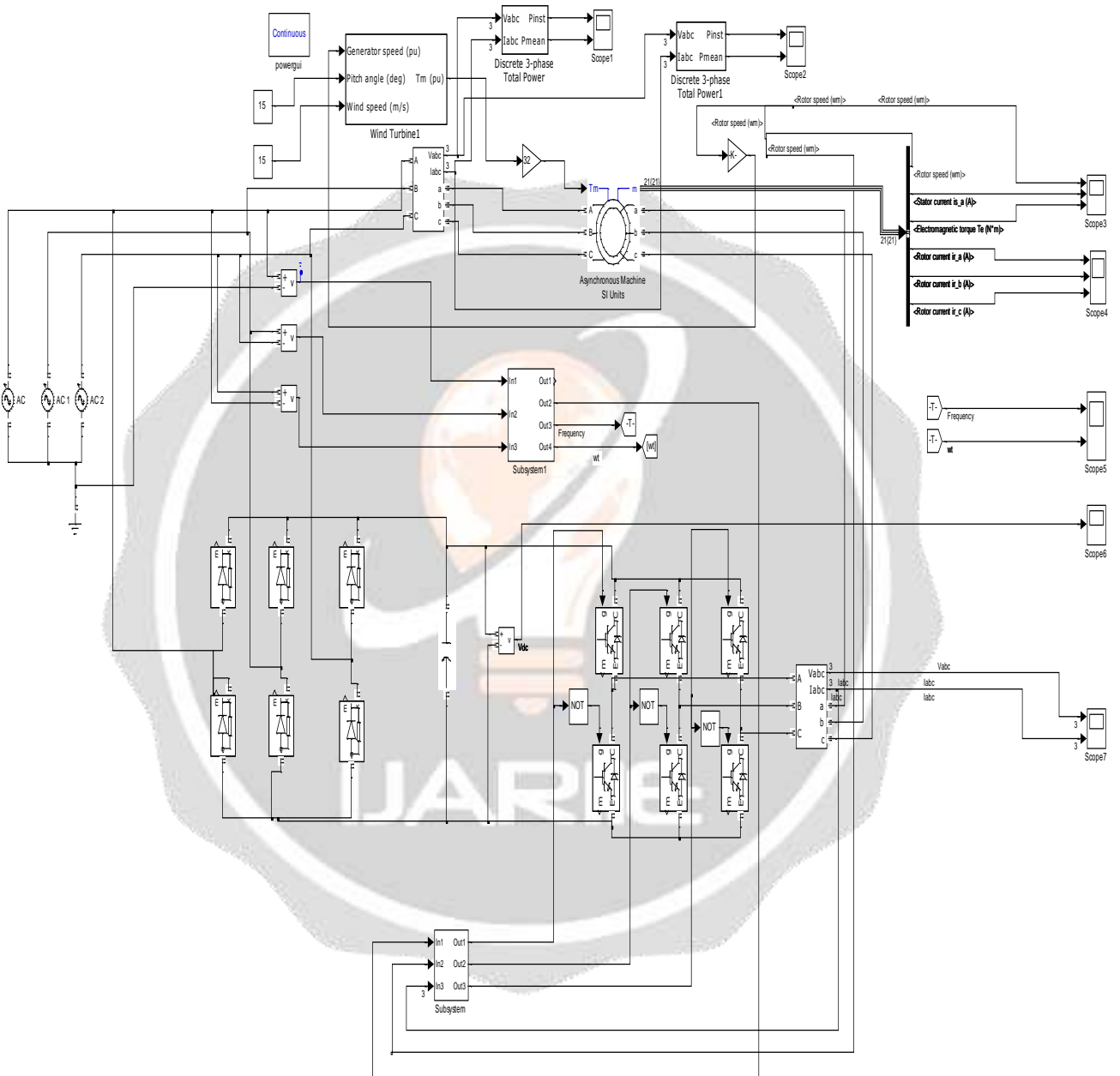

Fig3. Block diagram of DFIG with fault at grid side

**VI. SIMULATION MODEL**

Wind turbines using a doubly-fed induction generator (DFIG) consist of a wound rotor induction generator and an AC/DC/AC IGBT-based PWM converter. The stator winding is connected directly to the 50 Hz grid while the rotor is fed at variable frequency through the AC/DC/AC converter. The DFIG technology allows extracting maximum energy from the wind for low wind speeds by optimizing the turbine speed, while minimizing mechanical stresses on the turbine during gusts of wind. In this demo the wind speed is maintained constant.



**Fig4. Detailed simulink model of DFIG**

### VII. RESULTS AND ANALYSIS

A DFIG grid system was simulated in Matlab/Simulink with the DFIG being fed by a constant wind speed..

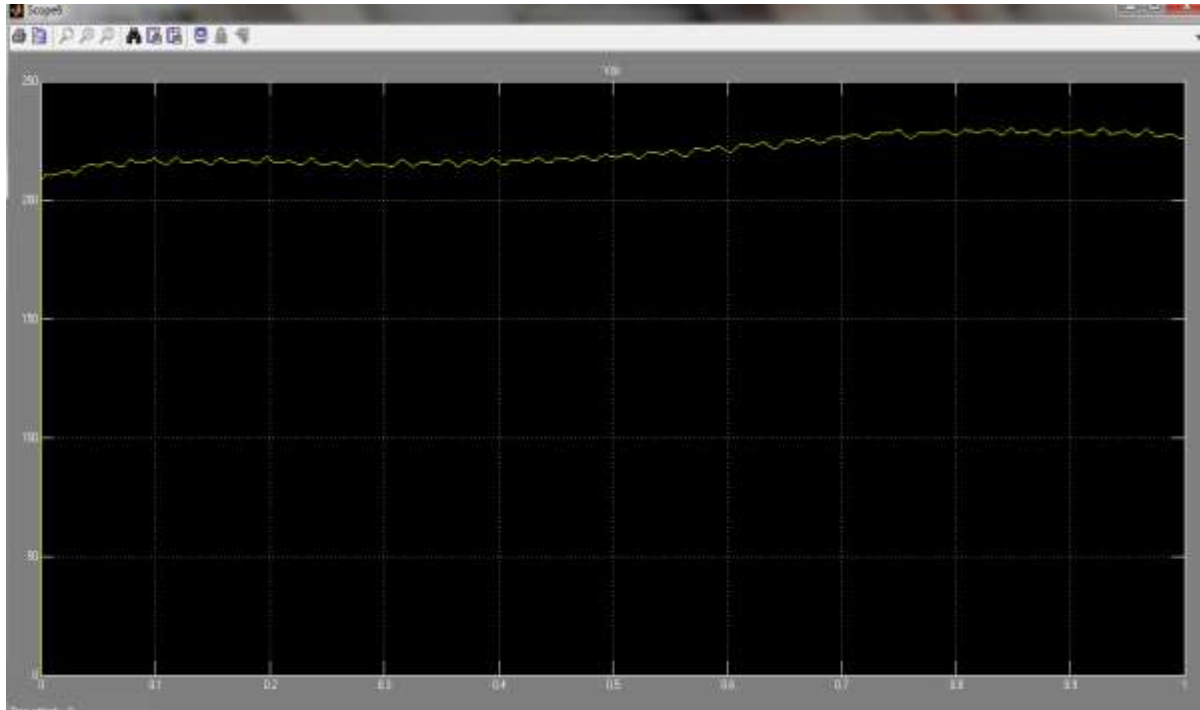

Fig5.  $V_{dc}$  Waveform

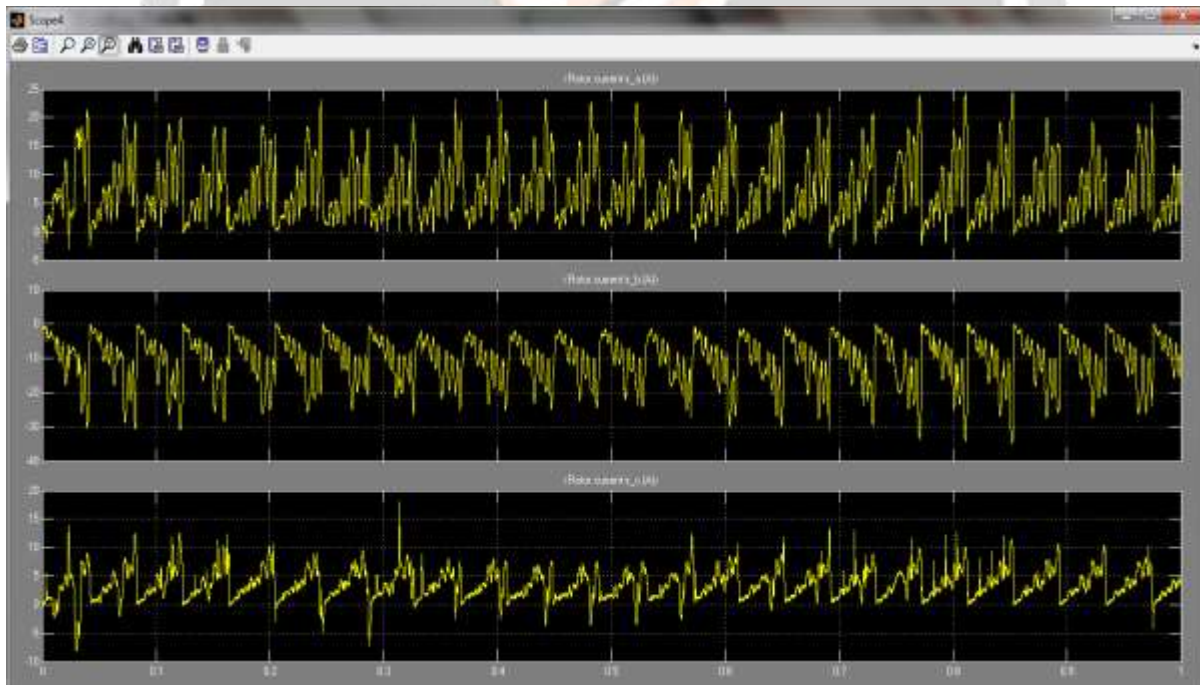
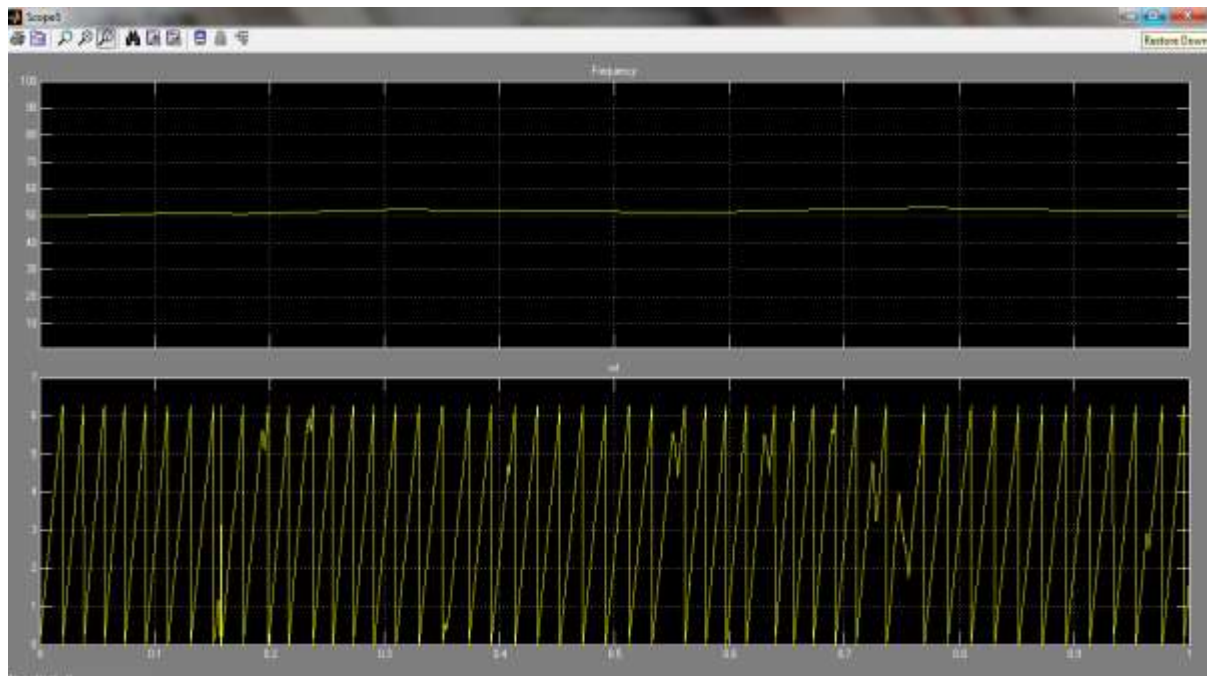
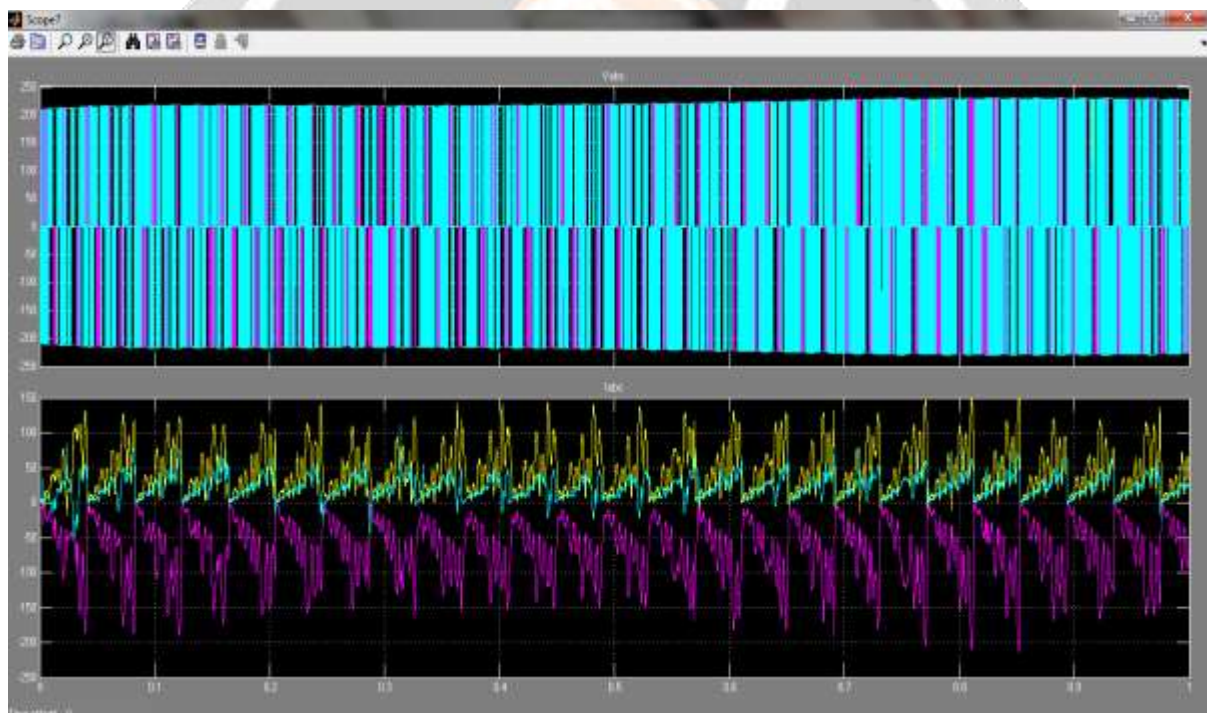

Fig6. Rotor Current Waveform



**Fig7. Frequency and  $\omega t$  Waveform**



**Fig8. Converter Output Waveform**

## X. Conclusion

In this paper we have discussed here the basic operation of DFIG and its controls using AC/DC/AC converter. So for best efficiency the DFIG system is used which is connected to grid side and has better control. The rotor side converter (RSC) usually provides active and reactive power control of the machine while the grid-side converter (GSC) keeps the voltage of the DC-link constant. So finally we simulated grid side and wind turbine side parameters and the corresponding results have been displayed.

The faults can occur when wind speed decreases to a low value or it has persistent fluctuations. The DFIG is able to provide a considerable contribution to grid voltage support during short circuit periods. Considering the results it can be said that doubly fed induction generator proved to be more reliable and stable system when connected to grid side with the proper converter control systems.

## References

- [1] T. Ackermann, *Wind Power in Power Systems*. Hoboken, NJ: Wiley, 2005 (ISBN: 0-470-85508-8).
- [2] IEEE Recommended Practices and Requirements for Harmonic Control in Electrical Power Systems, IEEE Standard 519-1992.
- [3] J. Morren, J. T. G. Pierik, S. W. H. de Haan, and J. Bozelie, —Grid interaction of offshore wind farms. Part 1. Models for dynamic simulation,| *Wind Energy*, vol. 8, no. 3, pp. 279– 293, Jul./Sep. 2005
- [4] J. G. Slootweg, S.W. H. de Haan, H. Polinder, and W. L. Kling, —General model for representing variable speed wind turbines in power system dynamics simulations,| *IEEE Trans. Power Syst.*, vol. 18, no. 1, pp. 144–151, Feb. 2003.
- [5] M. H. J. Bollen, *Understanding Power Quality Problems— Voltage Sags and Interruptions*. Piscataway, NJ: IEEE, 2000.
- [6] A. Peterson, —Analysis, modeling and control of doubly-fed induction generators for wind turbines,| Ph.D. dissertation, Electr. Power Eng.,Chalmers Univ. Technol., Goteborg, Sweden, 2005
- [7] F. Jiang, Z. Q. Bo, and R. Li, —Performance of induction generator in parallel with an unbalanced three phase system,| in *Proc. 1998, POWERCON*, 18–21 Aug., vol. 2, pp. 1193– 1197.
- [8] B. I. Naess, T. M. Undeland, and T. Gjengedal, —Methods for reduction of voltage unbalance in weak grids connected to wind plants,| in *Proc. IEEE Workshop Wind Power Impacts Power Syst.*, Oslo, Norway, Jun. 2002, pp. 1–7.
- [9] L. Holdsworth, X. G. Wu, and J. B. Ekanayake, —Comparison of fixed speed and doubly fed induction wind turbines during power system disturbances,| *Proc. Inst. Elect. Eng. Generation, Transm. Distrib.*, vol. 150, no. 3, pp. 343–352, May 2003.
- [10] H. A. Kim, —The instantaneous power theory based on mapping matrices in three-phase four-wire systems,| in *Proc. Power Converse. Conf.*, Nagaoka, Japan, Aug.1997, vol. 1, pp. 361–366
- [11] N. Akira and T. Tanaka, —A new definition of instantaneous active reactive current and power based on instantaneous space vectors on polar coordinates in three-phase circuits,| *IEEE Trans. Power Del.*, vol. 11, no. 3, pp. 1238–1343, Jul. 1996
- [12] J. S. Saccomando, —Transient operation of grid-connected voltage source converter under unbalanced voltage conditions,| in *Proc. Ind. Appl.Conf.*, 36th IAS Annu. Meeting, 2001, vol. 4, pp. 2419–2424
- [13] H. S. Song and K. Nam, —Dual current control scheme for PWM converter under unbalanced input voltage conditions,| *IEEE Trans. Ind. Electron.*, vol. 46, no. 5, pp. 953–959, Oct. 1999M.
- [14] S. Seman, J. Niiranen, and A. Arkkio, —Ride-through analysis of doubly fed induction wind-power generator under unsymmetrical network disturbance,| *IEEE Trans.Power Syst.*, vol. 21, no. 4, pp. 1782–1789,Nov. 2006
- [15] R. Pena, R. Cardenas, J. Clare, and P. Wheeler, —Control system for unbalanced operation of stand-alone doubly fed induction generators,| *IEEE Trans. Energy Convers.*, vol. 22, no. 2, pp. 544–545, Jun. 2007.