

“DESIGN OF HYDRAULIC PORTABLE CRANE”

Prof. Dipali Bhojar, Mr. Ashish R. Shewale
Department of Mechanical Engineering

ABSTRACT

This project deals with the fabrication of Hydraulic floor crane. The aim of this project work is to acquire practical knowledge in the field of material handling equipment with the help of hydraulic principle. This machine is very useful for lifting and transporting heavy jobs up to 3 kg for all types of jobs such as automobile repairs and service shops of central workshops, production industries, material handling units etc. In material handling, the cranes play a vital role in modern manufacturing industries. In our project we aim to fabricate a hydraulic operated floor crane for handling various kinds of materials. The hydraulic floor crane consists of truck, hydraulic cylinder, hydraulic tank, hydraulic hoses, DCV, beam and hooks. This portable crane uses a hydraulic system to lift a heavy loads applying only small force. In this project we designed and produced a portable crane which can lift a heavy load with a maximum capacity of 3 ton. The crane has two loaded side bars to make the base and two links (i.e. Vertical column and boom) connected each other by using pin joint. The Vertical column is secured on the cross bar that is welded to the side bars making the base using bolt connection.

Keywords:- Hydraulic, elements, cranes, portable, production industries, material, lifting, workshops, manufacturing, automobile, etc.

1.INTRODUCTION

A crane is a type of machine, generally equipped with a hoist rope, wire ropes or chains, and sheaves, that can be used both to lift and lower materials and to move them horizontally. It is mainly used for lifting heavy things and transporting them to other places. It uses one or more simple machines to create mechanical advantage and thus move loads beyond the normal capability of a human. Cranes are commonly employed in the transport industry for the loading and unloading of freight, in the construction industry for the movement of materials and in the manufacturing industry for the assembling of heavy equipment. In today world, hydraulic automation system play a vital role, it is actually an arrangement of different elements in order to regulate, direct, sense and command itself to achieve the desired result. In robotics system work can be carried out by mechanical, electrical, electronics. Pneumatics and hydraulics control system different types of sensors and controls remote in the development of variety of used different types of equipments according to requirements. The hydraulic automation has many advantages. By considering all these factors we try to make specially type hydraulic crane used for shifting of material from one place to another.



The aim of the project is to develop a semiautomatic portable hydraulic crane to avoid the manually effort. The objective of this work is to decrease the time required in transfer of material from one place to another thus it will be supportive for industrial sector.

The details of the objectives of the research project are listed as follows:-

- To design analytically the portable lifting machine lift slightly heavy objects that can't be carried by single worker

- To minimize cost expenditure for fuel that is made for operating fork lift in transporting every component in the production shop.
- Specifically in bus production factory to minimize wastage of time due to each station should wait for a single crane for lifting.
- To minimize risk of life and property.
- To produce the working prototype of portable, moveable crane for the production shop
- To determine the overall cost of the crane production.

2. LITERATURE REVIEW

[1] Asmita Jadhav, Mayank Kachroo, *IJRET: International Journal of Research in Engineering and Technology* eISSN 2319-1163 pISSN: 2321-7308 ,A REVIEW: FLOOR CRANES FOR INDUSTRIAL USE In day today Industrial practice material handling is a important phenomenon and can be defined as handling, movement, storage and control of materials or equipments throughout the entire process of manufacturing and in between the various process which are necessary to create a finish good. As a process material handling incorporates a wide range of manual, semi-automated and automated tools and equipments.

[2] V Jose Ananth Vino ,*International Journal of Scientific Research & Engineering Trends Volume 5, Issue 3, May-Jun-2019, ISSN (Online): 2395-566X* ,Design and Fabrication of Hydraulic and Mechanical Crane Lift A Simple hydraulic mechanical Movable crane is necessary mobile equipment for lifting and moving heavy loads used in small scale manufacturing and production industries. Due to the growing of small scale industry based on the current policy of the Government, the demand of load lifting equipments has increased. To deal with such a challenge, we have come up with the brilliant concept of designing and manufacturing a simple and affordable mobile floor crane which we hope will solve the problem of lifting equipments and minimizing manufacturing costs by reducing manpower.

[3] Amir Zavichi and Amir H. Behzadan *Vol-3 Issue-3 2017 IJARIE-ISSN(O)-2395-4396*,“HYDRAULIC CRANE” Cranes do play the most vital role in the manufacturing industries. In this project we aim to create a machine that reduces man power that is additional. This hydraulic floor crane consists of Base truck, hydraulic jack, wheels, hydraulic hoses, levers , direction control valve, horizonatal beam and hooks. There the beam is placed vertical can also called as support arm .is connected to the base plate and the hydraulic jack touching the hook used to lift the heavy industrial load. The hydraulic jack is lifted or operated outward with the help of reciprocating movement of lever connected to the hydraulic jack.

[4] Okolie Paul Chukwulozie, *International Journal of Engineering and Advanced Technology (IJEAT) ISSN: 2249 – 8958, Volume-3, Issue-2, December 2013* , Optimization in Design of Rotating Hydraulic Crane The main aim of the project is the design, analysis and production of a hydraulic floor crane having arm motion in the vertical as well as horizontal plane with 180 degree rotation. These hydraulic floor cranes provide an efficient, low cost alternative to other material handling equipments. Strong, robust, sturdy and built to very standard, these cranes are maneuverable in loading, unloading and shifting of heavy loads. Crane structure consists of chassis, vertical column, horizontal arm, and the hydraulic pump with cylinder assembly.

3. METHODOLOGY

Design, fabrication and testing of hydraulic crane is intended to replace the local or traditional method of lifting heavy load with hand with emphasis being laid on performance, safety and reliability. Also, hydraulic crane is capable of carrying load up to 50kg at a time was developed using locally available materials. The design of the hydraulic crane involved analysis of forces acting in various member of the crane structure, analysis of the links mechanism, determination of pressure developed in the actuator at maximum load, material selection and cost evaluation. Its fabrication details involved some workshop operations such as marking out, cutting, machining, welding and surface treatment which was accomplished using locally available materials.

Manufacturing

The hydraulic crane which was manufacture has 7 part. They are base plate/Truck/Pallet, Vertical column, Horizontal arm, Secondary horizontal arm, Hydraulic jack, Hook, Nut and bolt. Base plate are made of metal rod. The roads are cut according to dimension and they are welded using metal arc welding. Vertical column are fitted so it can rotate 360°. The fixed horizontal arm is welded. And secondary horizontal arm was fixed with hook. Hydraulic system are selected according to the power required and capacity of tank.

Machining process:

- Surface finishing
- Marking out
- Metal cutting
- Surface grinding
- Welding
- Finishing

Hydraulic cylinders get their power from pressurized hydraulic fluid, which is typically oil. The hydraulic cylinder consists of a cylinder barrel, in which a piston connected to a piston rod moves back and forth. The barrel is closed on one end by the cylinder bottom (also called the cap) and the other end by the cylinder head (also called the gland) where the piston rod comes out of the cylinder. The piston has sliding rings and seals. The piston divides the inside of the cylinder into two chambers, the bottom chamber (cap end) and the piston rod side chamber (rod end / head end). Flanges, trunnions, clevises, Lugs are common cylinder mounting options.

COMPONENTS UTILISED IN PROJECT

BOTTLE JACK : A bottle jack is a hydraulic jack which resembles a bottle in shape, having a cylindrical body and a neck, from which the hydraulic ram emerges. In a bottle jack the piston is vertical and directly supports a bearing pad that contacts the object being lifted. With a single action piston the lift is somewhat less than twice the collapsed height of the jack, making it suitable only for vehicles with a relatively high clearance. For lifting structures such as houses the hydraulic interconnection of multiple vertical jacks through valves enables the even distribution of forces while enabling close control of the lift. It work on pascals law.. Pascal's principle pressure applies in a confined fluid at rest is transmitted undiminished in all directions and act with equal force on equal area at right angle to them.



2. LIFTING HOOK

A lifting hook is a device for grabbing and lifting loads by means of a device such as a hoist or crane. A lifting hook is usually equipped with a safety latch to prevent the disengagement of the lifting wire rope sling, chain or rope to which the load is attached.

A hook may have one or more built-in pulley sheaves as a block and tackle to multiply the lifting force.



3. RUNNER WHEEL : A wheel is a circular component that is intended to rotate on an axle bearing. The wheel is one of the main components of the wheel and axle which is one of the six simple machines. Wheels, in conjunction with axles, allow heavy objects to be moved easily facilitating movement or transportation while supporting a load, or performing labor in machines. Wheels are also used for other purposes, such as a ship's wheel, steering wheel, potter's wheel and flywheel



4. DESIGN AND CALCULATIONS

There are three major considerations in the design of cranes.

1. The crane must be able to lift the weight of the load
2. The crane must not topple
3. The crane must not rupture

A floor crane is a portable type of device as shown in fig below. It is a tubular and rigid and light weight structure and consists of base frame having rollers for movement on the floor. A vertical post called as a mast is welded on the base frame and is further strengthened by giving bracings on both sides. A horizontal boom is connected to the mast by a pin joint. The boom is having a lifting hook at the end.

MATERIAL SELECTION

1.Selection of mild steel frames:- The material selection is also very much important because what material we are using whether it is capable of sustaining that load or not. For our project it is of medium load capacity so we are using mild steel of composition : C 15 Mn 75. The percentage of carbon varies from 0.1 to 0.2 % and this material can easily sustain the load.

2.Selection of wheels:- PREMIUM rubber caster wheels have a special compound of highly resilient soft rubber bonded to thick aluminum wheel centers. Unlike Conventional Mold on rubber caster wheels, PREMIUM rubber caster wheels can be moved manually when loaded to their rated capacities.

3.Types of contaminates:- There are many types of contaminates. The most common are: Particulate (dust, dirt, sand, fiber, rust, rubber, paint chips, metal flakes, etc.)

PROCEDURE FOR FINDING THE STROKE-

From the given specifications, the angle subtended by the arm for maximum and minimum heights at point Bis calculated through the use of basic trigonometry.

The angles are found out to be; (refer fig. 1) Angle $CBC'' = 300$

Angle $CBC' = 500$

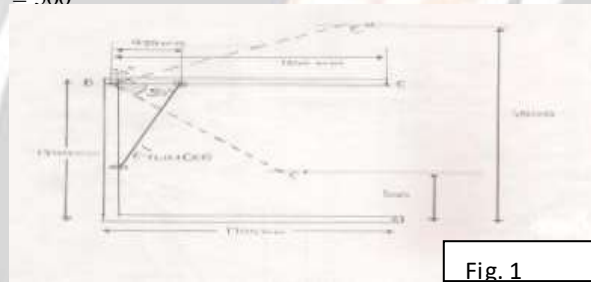

Fig. 1

Drawing the crane using a definite scale and from given specifications, the position of the hinges for piston and cylinder can be found out using geometry(refer fig. 2). The approx values are; Hinge for cylinder to be attached = 725mm from ground level Hinge for piston to be attached = 430mm from point B on the arm.

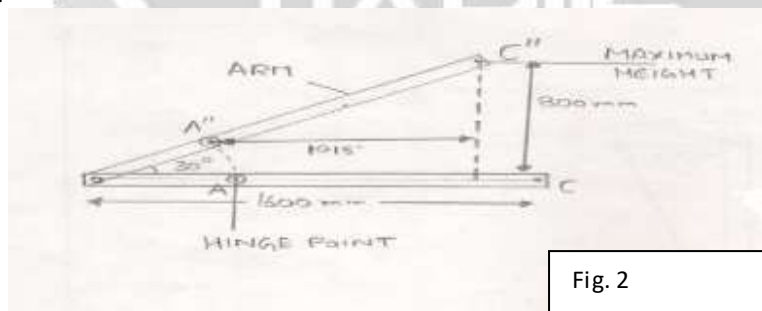
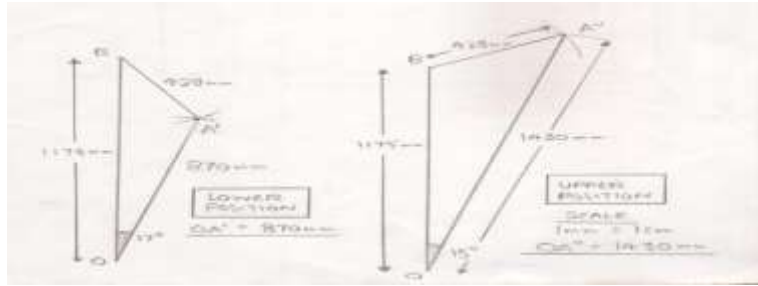

Fig. 2

1. The angles subtended by hinge for piston i.e. point A, about point O are calculated for maximum height and minimum height of arm. The required values are distance of hinge from point B and the angles subtended by the arm about point B i.e. 300 for uppermost position and 500 for lower most position. (refer fig. 3)
The angle subtended by cylinder when arm is at highest point = 150
The angle subtended by cylinder when arm is at lowest point = 170
2. From fig. 3 it can be calculated that how much the piston needs to extend .
The stroke of piston cylinder = 600mm



Various forces acting on arm at different lifting positions -
Taking moment about point O:

1. At middle position-

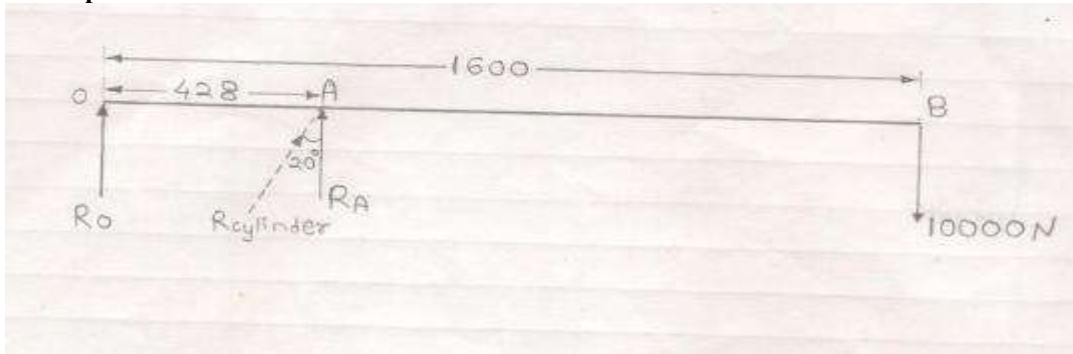

$$M_o = 10000 \cdot 1600 - R_A \cdot 428 = 0 \Rightarrow R_A = 37383 \text{ N}$$

Reaction in the direction of cylinder will be given by $R_{cylinder} = R_A (\cos 20)$

$$R_{cylinder} = 37383 (\cos 20)$$

$$R_{cylinder} = 35128 \text{ N}$$

$$R_o = 47383 \text{ N}$$

2. At upper position-

$$M_o = 0$$

$$M_o = 10000 \cdot (1600 \cos 30) + R_A \cdot (428 \cos 30) \Rightarrow R_A = 37383 \text{ N}$$

Reaction in the direction of cylinder will be given by $R_{cylinder} = R_A (\cos 15)$

$$R_{cylinder} = 36109 \text{ N}$$

$$R_o = -47383 \text{ N}$$

3. At lower position-

Similarly reaction in the direction of cylinder at extreme lower position

$$R_{cylinder} = 35750 \text{ N}$$

Hence it can be seen that, maximum force on cylinder is acting at upper position i.e.

$$R_{cylinder} = 36109 \text{ N}$$

DESIGN OF CYLINDER

Assuming the internal pressure, $(P_i) = 150 \text{ kg/cm}^2$ $(P_i) = \frac{150 \cdot 9.81}{10^2} \text{ kg/cm}^2$

$$(P_i) = 14.715 \text{ N/mm}^2$$

Material used for cylinder is Mild steel IS 226 Yield strength of mild steel = 250 N/mm²

Ultimate tensile strength of mild steel = 410 N/mm²

Factor of safety = 1.5 (assumed)

$$(P_i) = F/A$$

$$A = F/P_i$$

$$= 36109 / 14.715$$

$$A = 2453.89 \text{ mm}^2$$

$$\text{But, } A = (3.14/4) d^2$$

DESIGN OF CYLINDER

Assuming the internal pressure, $(P_i) = 150 \text{ kg/cm}^2$

$$(P_i) = 150 \times 9.81 / 10^2 \text{ kg/cm}^2$$

$$(P_i) = 14.715 \text{ N/mm}^2$$

Material used for cylinder is Mild steel IS 226

Yield strength of mild steel = 250 N/mm²

Ultimate tensile strength of mild steel = 410 N/mm²

Factor of safety = 1.5 (assumed)

$$(P_i) = F/A$$

$$A = F/P_i$$

$$= 36109 / 14.715$$

$$A = 2453.89 \text{ mm}^2$$

$$\text{But, } A = (\pi/4) d^2$$

$$2453.89 = (\pi/4) d^2$$

$$d = 55.89 \text{ mm}$$

Using cylinder of standard diameter,

Bore diameter = 63 mm

Now, allowable tensile strength $\sigma_{all} = \sigma_{yt} / \text{FOS}$

$$= 250 / 1.5$$

$$= 166.66 \text{ N/mm}^2$$

Allowable shear stress **Tall** = σ_{sy} / FOS

σ_{sy} = Yield strength in shear of the cylinder material, N/mm²

$$\text{Tall} = 0.5 \sigma_{yt} / \text{FOS}$$

$$= 0.5 \times 250 / 1.5$$

$$= 83.33 \text{ N/mm}^2$$

According to maximum principal stress theory thickness of cylinder,

Volume of column = L*B*H

$$= 1600 \times 150 \times 150$$

$$= 36000000 \text{ cu mm}$$

$$= 0.036 \text{ cu m}$$

Density of material used = 7800 kg/cu m

Mass of the column = volume * Density

$$= 0.036 \times 7800$$

$$= 280.8 \text{ kg}$$

Weight of the column = 280.8 * 9.81

$$= 2754 \text{ N}$$

Force on part four- Volume of base = L*B*H

$$= 1400 \times 150 \times 150$$

To calculate the moment at fulcrum point for verifying that the structure will not tilt or bend when the arm of the crane has been rotated by 90°, after applying the load;

$$= 0.0315 \text{ cu m}$$

Density of material used = 7800 kg/cu m Mass of the base = volume * Density

$$= 0.0315 \times 7800$$

$$= 245.7 \text{ kg}$$

Weight of the base = 245.7 * 9.81

$$= 241$$

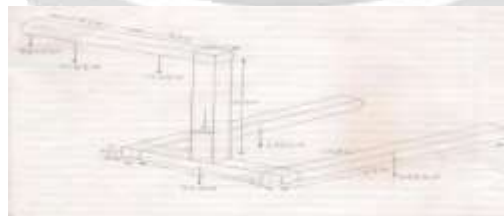

Forces on part one-

Load applied to the arm at the hook is 1000kg

$$\text{i.e.} = 1000 \times 9.81$$

$$= 9810 \text{ N}$$

Self weight of the overhanging part of arm-

Volume of overhanging arm = L*B*H

$$= 850 \times 150 \times 150$$

$$= 19125000 \text{ cu mm}$$

$$= 0.019125 \text{ cu m}$$

Density of the material used is = 7800 kg/cu m
 Mass of the overhanging arm= Volume*Density
 = 0.019125*7800
 = 149.175 kg

Weight of the overhanging arm= 149.175*9.81
 = 1463.406 N

Moment on fulcrum point due to left hand side forces-Mo= (9810*0.9) + (1463.406*0.487)
 = 9541.67 N-m

Force on part two-

Volume of remaining arm= L*B*H
 = 775*150*150
 = 17437500 cu mm
 = 0.0174375 cu m

Density of material used = 7800 kg/cu m
 Mass of the remaining arm= Volume*Density
 = 0.0174375*7800
 = 136.0125 kg

Weight of remaining arm= 136.125*9.81
 = 1334.2 N

Force on part three-

Volume of column= L*B*H
 = 1600*150*150
 = 36000000 cu mm
 = 0.036 cu m

Density of material used= 7800 kg/cu m
 Mass of the column= volume*Density
 = 0.036*7800
 = 280.8 kg

Weight of the column= 280.8*9.81
 = 2754 N

Force on part five-

Volume of base arm= L*B*H
 = 1600*150*150
 = 36000000 cu mm
 = 0.036 cu m

Density of material used= 7800 kg/cu m
 Mass of the base arm= volume*Density
 = 0.036*7800
 = 280.8 kg

Weight of the base arm= 280.8*9.81
 =2754 N

Moment on fulcrum point due to right hand side forces; Mo= (1334.2*0.31) + (2754*0.625) +
 (2754*0.8) +(2754*1.484) + (2410*0.625)
 = 9931.26 N-m

5.CAD MODEL

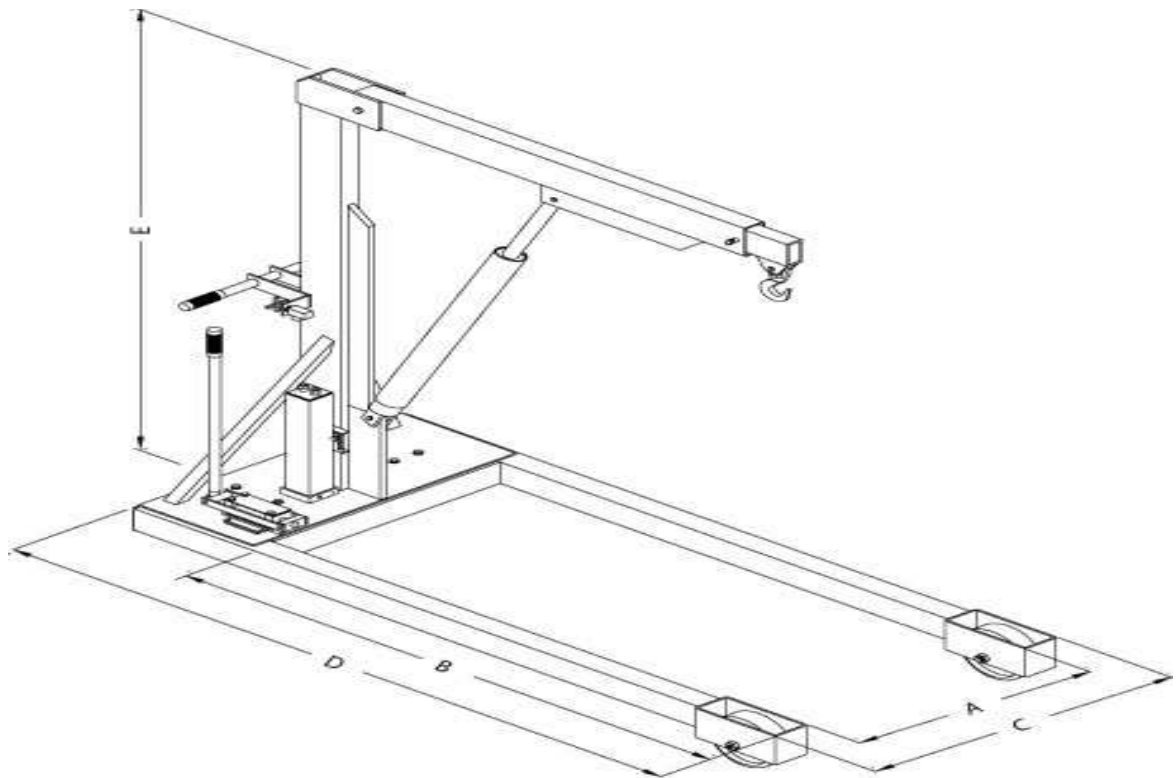

Fig: hydraulic crane

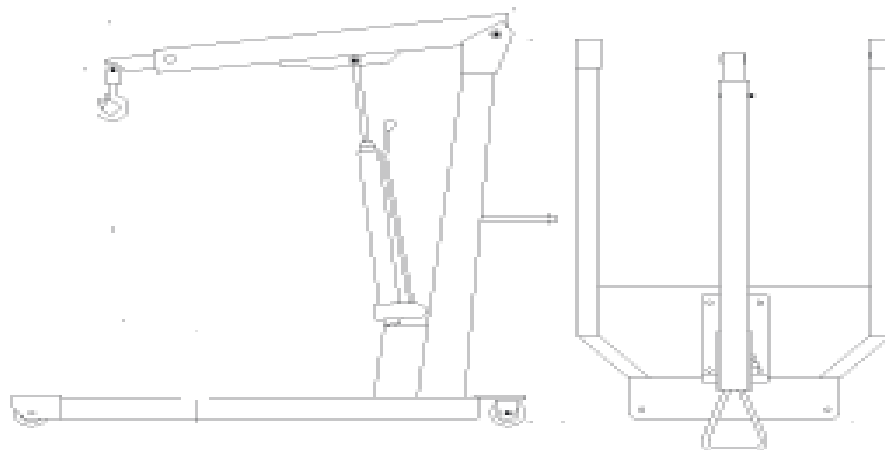

Fig: front and top view of innovation

6.APPLICATIONS

Used for load lifting, carrying and shifting operations in small, medium and large industries like,

1. Foundry
2. Welding workshops
3. Automobile workshops
4. Construction sites, etc.,

7. RESULT AND DISCUSSION

- In this paper we found that Hydraulic Floor crane mechanism is capable of lifting load. We analyse that design and fabrication was a great success both in terms of strength and stiffness.
- Of this lifting operation by using portable and moveable crane which is not being use before, we have identified that there is the need for using portable crane to lift up objects these are beyond the capacity and difficult of human power. Thus this paper provides the design of each part of portable crane. And the design analysis for each part is checked that it is safe accordingly the size of each parts of the crane.
- We accurately achieved our first goal of lifting the load and 360° rotary motion of the vertical column .
- Functional hydraulic floor crane mechanism which is capable of lifting load up to 2 tonne .

REFERENCES

- [1] **Okolie Paul Chukwulozie**, “Steel work design and analysis of floor cranes”, British Journal of Applied Science & Technology| Article No.BJAST.23079 May 2015 ISSN ISSN: 2231-0843, NLM ID: 101664541
- [2] **V Jose Ananth Vino**, “International Journal of Biotech Trends and Technology (IJBT)” –Volume 2/ Issue 1/ Number 1– Jan 2012,” ISSN: 2249-0183.
- [3] **A Balaji, H Jahir Hussein**, “International Journal of Science and Engineering Applications” Volume 3 Issue 5, 2014, ISSN-2319-7560 (Online).
- [4] **Asmita Jadhav, Mayank Kachroo, Mahesh Hegde, ruchita Mantri**, “Optimization in Design of Rotating Hydraulic Crane”, International Journal of Engineering and Advanced Technology (JEAT) ISSN: 2249-8958, Vol. 3, Dec 2013 pp. 76-82.
- [5] **Amir Zavichi and Amir H. Behzadan**, “Creating Automated Crane Work Plans Using Real Time Operational Data and Predictive Analysis”, Construction Research Congress 2012 @ ASCE 2012
- [6] **C.Canudas de Wit, H.Olsson, K.J. Aström & P. Lischinsky**: A New Model for Control of Systems with Friction. IEEE transactions on automatic control, vol. 40, no. 3, 1995.
- [7] **G.C.Goodwin, S.F.Graebe & M.E. Salgado**: Control System Design. Prentice Hall, New Jersey, 2001. [5]. Huang Li-Jenga* & Syu Hong-Jieb, “Seismic Response Analysis Of Tower Crane Using SAP200”, Procedia Engineering 79(2014), pp. 513-522.
- [8] **H.-J.Bartsch**: Taschenbuch mathematischer Formeln. Fachbuchverlag Leipzig im CarlHanser-Verlag, M`unchen, Wien, 18. Auflage, 1999.
- [9] **J.A.F. Ferreira**: Modelaç~ao de Sistemas Hidr`aulicos para Simulaç~ao com Hardware-inthe loop. PhD Thesis (in Spanish), University of Aveiro, Portugal, 2003.
- [10] **O.Egeland & J.T.Grawdahl**: Modeling and Simulation for Automatic Control. Marine Cybernetics AS, 2003 [10]. Thomas Telford, 1995 - Hydraulic Engineering - Hydraulics Of Spillways And Energy Dissipators Rajnikant M. Khatsuria.