

EFFECT ON RESPONSE REDUCTION FACTORS FOR RESISTING MOMENT IN FRAMES

W. Swaroop Sagar¹, Ch. Damodar Naidu²

¹P.G.Student, Department of Civil Engineering, Gokul Institute of Technology And Sciences.

²Assistant Professor, Department of Civil Engineering, Gokul Institute of Technology And Sciences.

ABSTRACT

Moment resisting frames are commonly used as the dominant mode of lateral resisting system in seismic regions for a long time. The poor performance of Ordinary Moment Resisting Frame (OMRF) in past earthquakes suggested special design and detailing to warrant a ductile behavior in seismic zones of high earthquake (zone ITT, IV & V). Thus when a large earthquake occurs, Special Moment Resisting Frame (SMRF) which is specially detailed with a response reduction factor, $R = 5$ is expected to have superior ductility. The response reduction factor of 5 in SMRF reduces the design base shear and in such a case these building rely greatly on their ductile performance. To ensure ductile performance, this type of frames shall be detailed in a special manner recommended by IS 13920. The objective of the present study is to evaluate the R factors of these frames from their nonlinear base shear versus roof displacement curves (pushover curves) and to check its adequacy compared to code recommended R value. The accurate estimation of strength and displacement capacity of nonlinear pushover curves requires the confinement modeling of concrete as per an accepted confinement model. A review of various concrete confinement models is carried out to select appropriate concrete confinement model. It is found that modified Kent and Park model is an appropriate model and it is incorporated in the modeling of nonlinearity in concrete sections. The frames with number of storey's 2, 4, 8, and 12 (with four bays) are designed and detailed as SMRF and OMRF as per IS 1893 (2002). The pushover curves of each SMRF and OMRF frames are generated and converted to a bilinear format to calculate the behavior factors. The response reduction factors obtained show in general that both the OMRF and SMRF frames, failed to achieve the respective target values of response reduction factors recommended by IS 1893 (2002) marginally. The components of response reduction factors such as over-strength and ductility factors also evaluated for all the SMRF and OMRF frames. It was also found that shorter frames exhibit higher R factors and as the height of the frames increases the R factors decreases.

Keyword - OMRF, SMRF, Response Reduction Factor, Pushover, Ductility, Confinement Models I.

1. INTRODUCTION

Column shear failure has been identified as the frequently mentioned cause of concrete structure failure and downfall during the past earthquakes. In the earthquake resistant design of reinforced concrete sections of buildings, the plastic hinge regions should be strictly detailed for ductility in order to make sure that severe ground shaking during earthquakes will not cause collapse of the structure. The most important design consideration for ductility in plastic hinge regions of reinforced concrete columns is the provision of adequate transverse reinforcement in the form of spirals or circular hoops or of rectangular arrangements of steel. cover concrete will be unconfined and will eventually become ineffective after the compressive strength is attained, but the core concrete will continue to carry stress at high strains. Transverse reinforcements which are mainly provided for resisting shear force, helps in confining the core concrete and prevents buckling of the longitudinal bars. The core concrete which remains confined by the transverse reinforcement is not permitted to dilate in the transverse direction, thereby helps in the enhancement of its peak strength and ultimate strain capacities. Thus confinement of concrete by suitable arrangements of transverse reinforcement results in a significant increase in both the strength and the ductility of

compressed concrete. Confining reinforcements are mainly provided at the column and beam ends and beam-column joints.

The hoops should enclose the whole cross section excluding the cover concrete and must be closed by 135° hooks embedded in the core concrete, this prevents opening of the hoops if spalling of the cover concrete occurs. Seismic codes recommend the use of closely spaced transverse reinforcement in-order to confine the concrete and prevent buckling of longitudinal reinforcement. Ductile response demands that elements yield in flexure and shear failure has to be prevented. Shear failure in columns, is relatively brittle and can lead to immediate loss of lateral strength and stiffness. To attain a ductile nature, special design and detailing of the RC sections is required. IS 13920 recommends certain standards for the provision of confining reinforcements for beams and columns. The code suggests that the primary step is to identify the regions of yielding, design those sections for adequate moment capacity, and then estimate design shears founded on equilibrium supposing the flexural yielding sections improve credible moment strengths. The probable moment capacity is considered using methods that give a higher estimate of the moment strength of the planned cross section. Transverse reinforcement provision given in IS 13920 is given in Figures for Columns and beams.

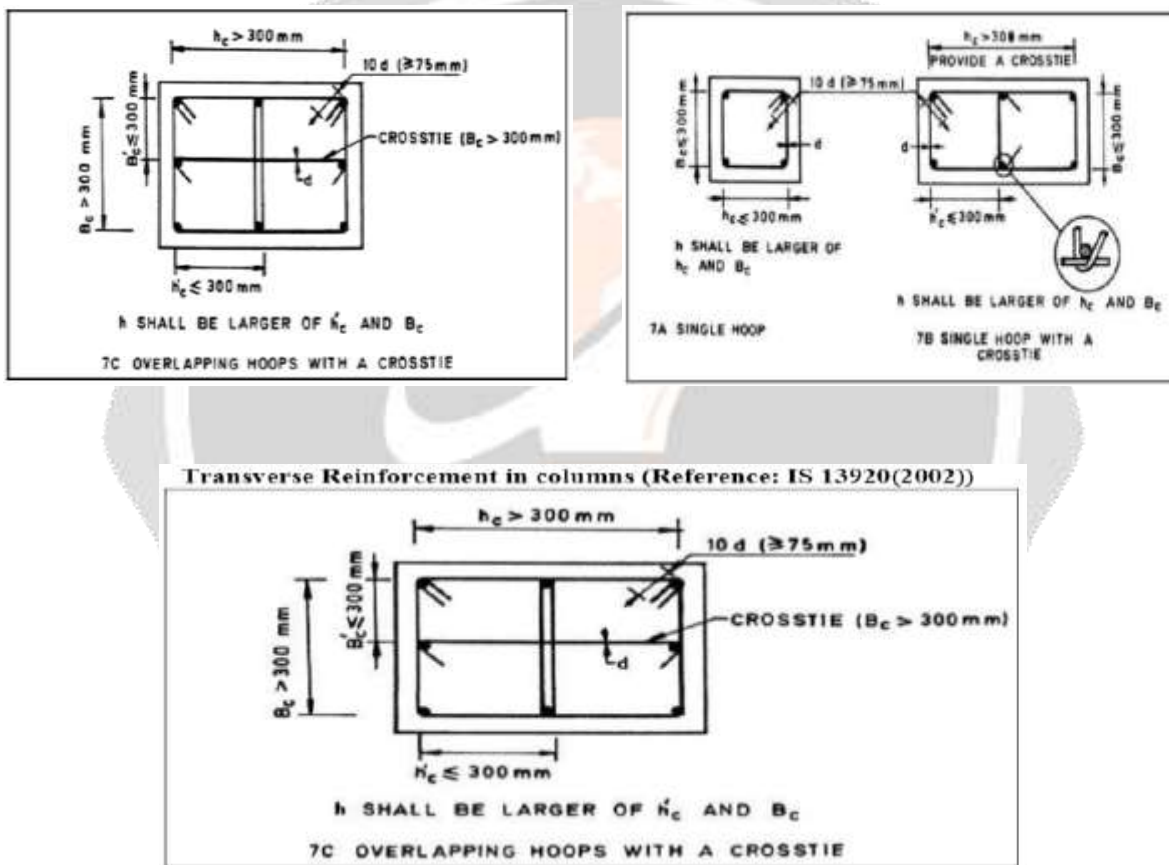

Fig 3 — Shear Reinforcement in beams (Reference: IS 13920(2002))

2. Special And Ordinary Moment Resisting Frames (SMRF AND OMRF)

According to Indian standards moment resisting frames are classified as Ordinary Moment Resisting Frames (OMRF) and Special Moment Resisting Frames (SMRF) with response reduction factors 3 and 5 respectively.

Another main difference is the provision of ductile detailing according to IS 13920 as explained in Section 1.1 for the SMRF structures. The differences between these two are given in Table 1

SMRF	OMRF
It is a moment-resisting frame specially detailed to provide ductile behavior and comply with the requirements given in IS 13920.	It is a moment-resisting not meeting special detailing requirement for ductile behavior.
Used under moderate-high earthquakes	Used in low earthquakes
$R = 5$	$R = 3$
Low design base shear.	High design base shear.
It is safe to design a structure with Ductile detailing.	It is not safe to design a structure without ductile detailing.

Table 1 Differences between SMRF and OMRF

2.1 SMRF and OMRF : IS 1893 (Part 1), 2002. Criteria for earthquake resistant design of structures Part 1 General provisions and buildings, Bureau of Indian Standards (BIS) classifies RC frame buildings into two classes, Ordinary Moment Resisting Frames (OMRF) and Special Moment Resisting Frames (SMRF) with response reduction factors 3 and 5 respectively. Response Reduction Factor (R) is the factor by which the actual base shears that would be generated if the structure were to remain elastic during its response to the Design Basis Earthquake (DBE) shaking, shall be reduced to obtain the design lateral force. ACI 318: Building code requirements for reinforced concrete and commentary, published by American Concrete Institute. ASCE 7 classifies RC frame buildings into three ductility classes: Ordinary Moment Resisting Frame (OMRF), Intermediate Moment Resisting Frames (IMRF) and Special Moment Resisting Frames (SMRF) and corresponding reduction factors are 3, 5 and 8, respectively. Euro-code 8: Design of structures for earthquake resistance - Part 1: General rules, seismic actions and rules for buildings, European Committee for Standardization, aims to ensure the protection of life during a major earthquake simultaneously with the restriction of damages during more frequent earthquakes. Euro-code 8 (EN 1998-1) classifies the building ductility as Ductility Class low (DCL) that does not require delayed ductility and the resistance to seismic loading is achieved through the capacity of the structure and reduction factor $g = 1.5$, Ductility Class Medium (DCM) that allows high levels of ductility and there are responsive design demands with reduction factor $1.5 < q < 4$ and Ductility Class High (DCH) that allows even higher levels of ductility. Uma and Jain (2006) conducted a critical review of recommendations of well-established codes regarding design and detailing aspects of beam column joints. The codes of practice considered are ACI 318M-02, NZS 3101: Part 1:1995 and the Euro-code 8 of EN 1998-1:2003. It was observed that ACI 318M-02 requires smaller column depth as compared to the other two codes based on the anchorage conditions. NZS 3101:1995 and EN 1998-1:2003 consider the shear stress level to obtain the required stirrup reinforcement whereas ACI 318M-02 provides stirrup reinforcement to retain the axial load capacity of column by confinement. ACI requires transverse reinforcement in proportion to the strength of the concrete whereas NZS sets limits based on the level of nominal shear stress that is experienced by the joint core. EN provides shear reinforcement to confine the joint and to bring down the maximum tensile stress to design value. NZS and EN codes emphasize on provision of 13 5° hook

2.2 Ductility: V. Gioncu (2000) performed the review for ductility related to seismic response of framed structures. The required ductility was determined at the level of full structure behavior, while the available ductility was obtained as local behavior of node (joint panel, connections or member ends). The checking for ductility of columns is generally a difficult operation. For SMRF structures, the column sections are enlarged to achieve a global mechanism. This over-strength of the column may reduce the available ductility of columns. At the middle frame height a drastic reduction of available ductility was observed. Since the required ductility is maximum at this height, the collapse of the building may occur due to lack of sufficient ductility. This was commonly observed during the Kobe earthquake, where many building were damaged on the storey's situated at the middle height of structure. It was observed that the factors regarding seismic actions, such as velocity and cycling loading, reduce the available ductility. Sungjinera/. (2004) studied different factors affecting ductility. Evaluation of the distortion capacity of RC columns is very important in performance-based seismic design. The deformation capacity of columns is generally being expressed in numerous ways which are curvature ductility, displacement ductility or drift. The influence of concrete strength, longitudinal reinforcement ratio, volumetric ratio of confining reinforcement, shear span-to-depth ratio and axial load on various ductility factors were evaluated and discussed.

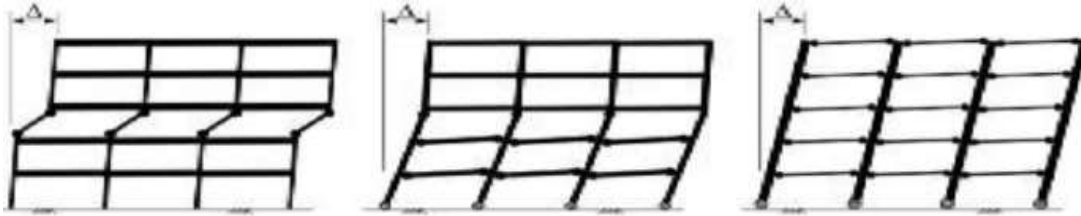

Fig: 4: Story mechanism Intermediate mechanism Beam mechanism (Reference: Moehle et ai., 2008)

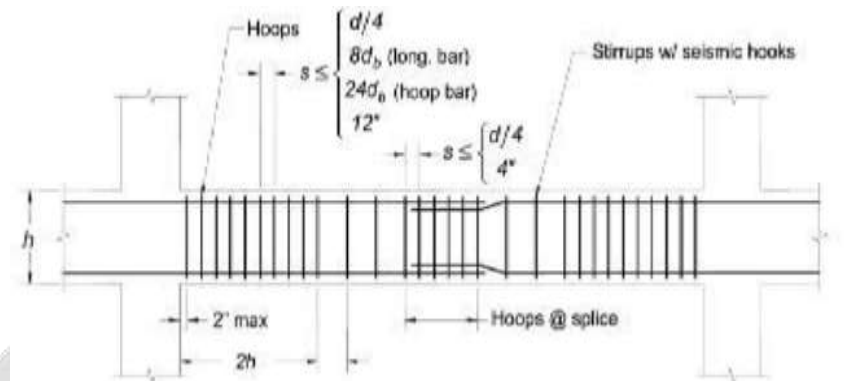

Fig: 5Hoop and stirrup location and spacing requirements.

2.3 Response Reduction Factor: Mondal et al. (2013) conducted a study to find R for reinforced concrete regular frame assemblies designed and detailed as per Indian standards IS 456, IS 1893 and IS13920. Most seismic design codes today comprise the nonlinear response of a structure obliquely through a 'response reduction/modification factor' (R). This factor permits a designer to use a linear elastic force-based design while accounting for nonlinear behavior and deformation limits. This research was aimed on the estimation of the actual values of this factor for RC moment frame buildings designed and detailed as per Indian standards for seismic and RC designs and for ductile detailing, and comparing these values with the value given in the design code. Values of R were found for four designs at the two performance levels. The results showed that the Indian standard suggests a higher value of R , which is potentially hazardous. Since Indian standard IS 1893 does not provide any clear definition of limit state, the Structural Stability performance level of ATC-40 was used here, both at the structure level and at the member levels. In addition to this, actual member plastic rotation capacities, were also calculated. Priestley recommended an ultimate concrete compression strain for unconfined concrete = 0.005. The ultimate compressive strain of concrete confined by transverse reinforcements as defined in ATC-40 was taken in this work to obtain the moment characteristics of plastic hinge segments. In order to prevent the buckling of longitudinal reinforcement bars in between two successive transverse reinforcement hoops, the limiting value of ultimate strain was limited to 0.02. Suitable modeling of the preliminary stiffness of RC beams and columns is one of the important aspects in the performance evaluation of reinforced concrete frames. Two performance limits (PL1 and PL2) were considered for the estimation of R for the study frames. The first one resembled to the Structural Stability limit state defined in ATC-40. This limit state is well-defined both at the storey level and at the member level. The second limit state was based on plastic hinge rotation capacities that were found for each individual member depending on its cross-section geometry. The global performance limit for PL1 was demarcated by a maximum inter-storey drift ratio of $0.33V_i/P_i$. The R values attained were ranging from 4.23 to 4.96 for the four frames that were considered, and were all lesser than specified value of R ($= 5.0$) for SMRF frames in the IS 1893. The taller frames exhibited lower R values. Component wise, the shorter frames (two-storey and four-storey) had more over-strength and R_s , but slightly less ductility and R_u compared to the taller frames. According to Performance Limit 1 (ATC-40 limits on inter-storey drift ratio and member rotation capacity), it was found that the Indian standard overestimates the R factor, which leads to the potentially dangerous underestimation of the design base shear. Based on Performance Limit 2 the IS 1893 recommendation was found to be on the conservative side.

3. Comparison Of Stress-Strain Curves For The Designed Sections

The stress-strain curve of concrete depends on the amount of confinement. In order to show the comparison of stress-strain curve using various models, the RC sections of the building frames discussed in the previous section are considered. The parameter for strength enhancement as per the two confinement models are calculated for each sections and tabulated in the table 3.6. The values of stress strain data are calculated using the strength enhancement parameter as per various confinement models discussed in the above section for selected RC sections. The obtained stress-strain curves are plotted

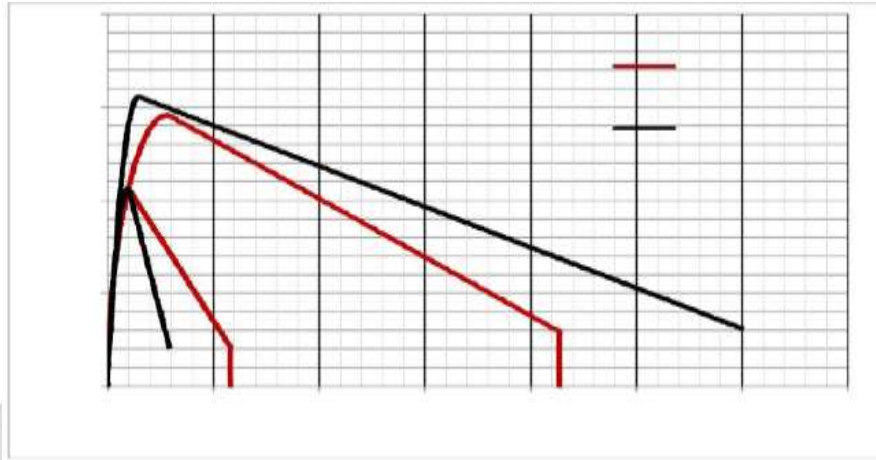
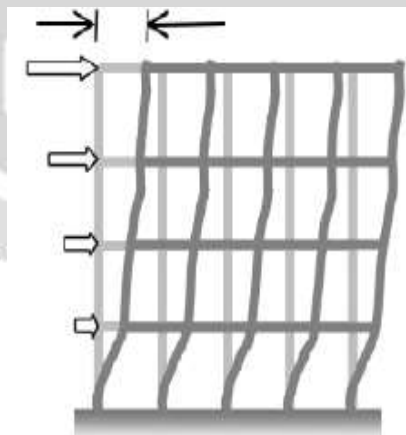

Fig: 6 Comparison of stress-strain curves using two confinement models (Razvi and Modified Kent models) for the RC section 400C-2S4B-SM ($K_1 = 6.47$, $K = 1.47$)

3.1 Limiting Values of Stress and Strain : Taking into account the spalling of the concrete cover if in case the strain outside the confined core exceeds the ultimate compressive strain of unconfined concrete, Priestley (1997) suggested an ultimate concrete strain of unconfined concrete, $= 0.005$. This limiting value is adopted in present study. The ultimate compressive strain of confined concrete as defined in ATC-40 is given below.

$$= 0.005 + < 0.02 \quad (3.28)$$



From the research conducted by Mondal et al. (2012), it was suggested that in-order to avoid the buckling of longitudinal reinforcement bars in between two successive transverse reinforcement hoops, ultimate compressive strain of confined concrete can be restricted to the limiting value of 0.02 as per the ATC-40 specifications. Thus in the present study an ultimate concrete strain of unconfined concrete, $= 0.005$ and ultimate compressive strain of confined concrete, $= 0.02$ is adopted.

4.BUILDING CONFIGURATIONS AND DESIGN DETAILS

A total of 4 plane frames are selected with number of storey’s 2, 4, 8 and 12, keeping the same number of bays as shown in Fig. The storey height and bay width of all the frames are 3 m and 5 m respectively. The frames are assumed to be located in seismic zone IV, the soil type chosen is medium and importance factor of 1.0 is assumed. The dead and live loads are calculated using IS 875 Part 1 (1987) and lateral loads are calculated as per IS 1893(2002).

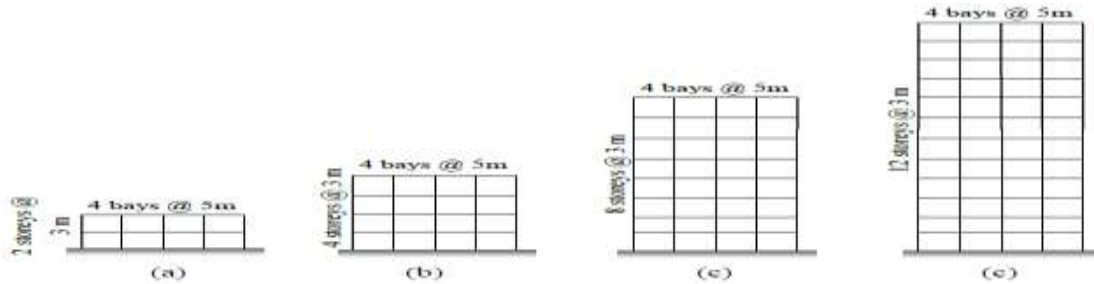

Fig 8. Elevation of frames considered

A total of 4 plane frames are selected with number of storey’s 2, 4, 8 and 12, keeping the same number of bays as shown in Fig 3.1. The storey height and bay width of all the frames are 3 m and 5 m respectively. The frames are assumed to be located in seismic zone IV, the soil type chosen is medium and importance factor of 1.0 is assumed. The dead and live loads are calculated using IS 875 Part 1 (1987) and lateral loads are calculated as per IS 1893(2002).

Sl No:	Frame Tag	No. of storey	No. of bays	Frame type	R	Analysis Design & Detailing
1	2S4B- SMRF	2	4	SMRF	5	IS 1893 & IS 13920
2	2S4B- OMRF	2	4	OMRF	3	IS 1893 & IS 456
3	4S4B- SMRF	4	4	SMRF	5	IS 1893 & IS 13920
4	4S4B- OMRF	4	4	OMRF	3	IS 1893 & IS 456
5	8S4B- SMRF	8	4	SMRF	5	IS 1893 & IS 13920
6	8S4B- OMRF	8	4	OMRF	3	IS 1893 & IS 456
7	12S4B- SMRF	12	4	SMRF	5	IS 1893 & IS 13920
8	12S4B- OMRF	12	4	OMRF	3	IS 1893 & IS 456

Table 2: Details of the Moment Resisting Frames considered

Each plane frame is designed as both SMRF and OMRF. OMRF frames are designed with a response reduction factor of 3 and SMRF with a response reduction factor of 5 in compliance with IS 1893 (2002). The design of RC sections are done as per IS 456 for OMRF frames and the design and ductile detailing of SMRF frames are done conforming to IS 13920 specifications. For convenient and easy presentation of frames, a naming standard has been used. The frame designated as 4S4B-SMRF represents SMRF building with four storey’s and four bays. The designation, type of design, R factor and analysis, design and detailing provisions followed are tabulated in the Table.

Factors	SMRF	OMRF
Seismic Zone	IV	IV
Zone Factor	0.24	0.24
Type of Building, Z	Regular office Building	Regular office Building
Importance Factor, I	1	1
Response Reduction Factor, R	5	3
Type of Soil	Medium	Medium
Damping	5%	5%

Table 3: Response Spectrum Factors Considered for the Frames

Moment resisting frame structures of different heights are selected to characteristically represent short, medium and long period structures. In the present study, the grade of steel used is Fe 415, compressive strength of the cube (f_{ck}) is considered as 25 MPa which corresponds to a cylinder strength (f_c') of 21.25 MPa. The modulus of elasticity of steel considered is 200 GPa and that of concrete is 25 GPa (5000). The live load is taken as 3 kN/m². The unit weight of concrete and brick masonry infill is taken as 25 kN/m³ and 19 kN/m³ (including the floor finishes) respectively. The thickness of slab is assumed as 175 mm and that of infill wall is taken as 230 mm. The reinforcement details for the RC sections are given in Table . A naming convention has been done for the RC sections used in frames as shown in Tables. A section designated as 450C-4S4B-SM indicates a column section of size 450 x 450 in the four storey four bay SMRF frame. Similarly, for a section designated as 350B-2S4B-SM indicates a beam section of depth 350 mm in the two storey four bay SMRF frame. The value of the various factors considered for the estimation of design horizontal seismic co-efficient, A_h is given in Table .

Frame Type	Height (m)	Time Period, T (sec)	S_a/g	A_h	Seismic Weight, W (kN)	Design Base Shear, V_d (kN)
2S4B-SMRF	6.0	0.2875	2.5	0.06	3537.3	212
2S4B-OMRF	6.0	0.2875	2.5	0.1	3804.7	380.4
4S4B-SMRF	12.0	0.483	2.5	0.06	5356.11	321.36
4S4B-OMRF	12.0	0.483	2.5	0.1	5408.9	540.89
8S4B-SMRF	24.0	0.813	1.672	0.04	10790.02	431.613
8S4B-OMRF	24.0	0.813	1.672	0.0668	11156.45	745.25
12S4B-SMRF	36.0	1.1022	1.233	0.0295	17146.31	505.87
12S4B-OMRF	36.0	1.1022	1.233	0.0493	17649.81	853.035

Table 4: Details of time periods, seismic weight and design base shear

Section Tag	Building Configuration	Section Size (mm x mm)	Longitudinal Reinforcement	Shear Reinforcement
400C-2S4B-SM	2S4B-SMRF	400 x 400	8 # 16 mm	2 legged 10mm @ 85mm c/c
450C-2S4B-OM	2S4B-OMRF	450 x 450	4 # 25 mm	2 legged 8mm @ 230mm c/c
450C-4S4B-SM	4S4B-SMRF	450 x 450	4 # 25 mm	2 legged 12mm @ 85mm c/c
500C-4S4B-OM	4S4B-OMRF	500 x 500	8 # 20 mm	2 legged 8mm @ 190mm c/c
550C-8S4B-SM	8S4B-SMRF	550 x 550	8 # 20 mm	2 legged 12mm @ 75mm c/c
650C-8S4B-OM	8S4B-OMRF	650 x 650	8 # 25 mm	2 legged 8mm @ 190mm c/c
600C-12S4B-SM	12S4B-SMRF	600 x 600	12 # 20 mm	2 legged 10mm @ 75mm c/c
700C-12S4B-OM	12S4B-OMRF	700 x 700	8 # 25 mm	2 legged 8mm @ 190mm c/c

Table 5: Reinforcement Details for Columns

Section Tag	Building Configuration	Section Size (mm x mm)	Longitudinal Reinforcement		Shear Reinforcement
			Top	Bottom	
350B-2S4B-SM	2S4B-SMRF	300 x 350	7 # 20 mm	5 # 16 mm	2 legged 10mm @ 100mm c/c
350B-2S4B-OM	2S4B-OMRF	300 x 350	8 # 20 mm	5 # 16 mm	2 legged 8mm @ 230mm c/c
375B-4S4B-SM	4S4B-SMRF	300 x 375	6 # 20 mm	2 # 20 mm	2 legged 10mm @ 100mm c/c
375B-4S4B-OM	4S4B-OMRF	300 x 375	6 # 20 mm	3 # 20 mm	2 legged 8mm @ 230mm c/c
400B-8S4B-SM	8S4B-SMRF	300 x 400	6 # 20 mm	3 # 20 mm	2 legged 10mm @ 100mm c/c
400B-8S4B-OM	8S4B-OMRF	300 x 400	5 # 25 mm	8 # 12 mm	2 legged 8mm @ 230mm c/c
600B-12S4B-SM	12S4B-SMRF	300 x 600	6 # 20 mm	10 # 12 mm	2 legged 10mm @ 100mm c/c
600B-12S4B-OM	12S4B-OMRF	300 x 600	5 # 25 mm	10 # 12 mm	2 legged 8mm @ 230mm c/c

Table 6: Reinforcement Details for Beams

Section	Column Section (mm x mm)	Hoop Volumetric Ratio (ρ_s)	Strength Enhancement Factor (K)
400C-2S4B-SM	400 x 400	0.0238	1.4654
450C-2S4B-OM	450 x 450	0.0048	1.0940
450C-4S4B-SM	450 x 450	0.0297	1.5803
500C-4S4B-OM	500 x 500	0.0051	1.1002
550C-8S4B-SM	550 x 550	0.0263	1.5141
650C-8S4B-OM	650 x 650	0.0037	1.0730
600C-12S4B-SM	600 x 600	0.0104	1.3206
700C-12S4B-OM	700 x 700	0.0034	1.0670

Table 7: Confinement Factors for Column Sections as per Kent and Park Model

OpenSees (Open System for Earthquake Engineering Simulation) platform is used for modeling of the structure. OpenSees is an object oriented open-source software framework used to model structural and geotechnical systems and simulate their earthquake response. It is primarily written in C++ and uses some FORTRAN and C numerical libraries for linear equation solving, and material and element customs. The progressive capabilities for modelling and analysing the nonlinear response of systems using a wide range of material models, elements, and solution algorithms makes this open source platform more popular. Concrete behavior is modeled by a uniaxial modified Kent and Park model with degrading, linear, unloading/reloading stiffness no tensile strength. Steel behavior is represented by a uniaxial Giuffre-Menegotto—Pinto model. The strain hardening ratio is assumed as 5%. Fiber Section modeling of element is done according to Spacone et al., (1996). The ultimate strain for confined concrete is taken as 0.02 as per ATC-40 specifications and that for unconfined concrete is considered as 0.005 as per Priestley (1997).

Frame	Δ_u (mm)	Δ_y (mm)	V_u (kN)	V_d (kN)	$\mu = \frac{\Delta_u}{\Delta_y}$	$\Omega = \frac{V_u}{V_d}$
SMRF Frames						
2S4B	200.23	50.02	425.52	212.02	4.00	2.01
4S4B	520.28	110.02	572.41	321.36	4.73	1.78
8S4B	626.36	200.12	692.8	431.6	3.13	1.61
12S4B	612.93	155.64	861.64	505.87	3.94	1.70
OMRF Frames						
2S4B	135.02	43	569.41	380.47	3.139	1.49
4S4B	316.02	106	689	540.8	2.981	1.27
8S4B	483.369	180	876.029	745.26	2.55	1.36
12S4B	505	190	952.5	853.03	2.65	1.116

Table 8: The details of the behaviour factors are calculated for the SMRF buildings as shown

Frame	R_s	R_μ	R_R	R
SMRF frames				
2S4B	2.007	2.42	1	4.856
4S4B	1.781	2.71	1	4.827
8S4B	1.605	2.63	1	4.229
12S4B	1.703	2.52	1	4.305
OMRF frames				
2S4B	1.49	2.007	1	2.99
4S4B	1.27	2.062	1	2.63
8S4B	1.176	1.893	1	2.226
12S4B	1.116	1.974	1	2.202

Table 9 : Response reduction factors and the components (Behavior factors)

4.1 Pushover Analysis: Pushover analysis is a static, nonlinear procedure to analyze the seismic performance of a building where the computer model of the structure is laterally pushed until a specified displacement is attained or a collapse mechanism has occurred as shown in Fig: 4.1. The loading is increased in increments with a specific predefined pattern such as uniform or inverted triangular pattern. The gravity load is kept as a constant during the analysis. The structure is pushed until sufficient hinges are formed such that a curve of base shear versus corresponding roof displacement can be developed and this curve known as pushover curve. A typical Pushover curve is shown in Fig 4.1. The maximum base shear the structure can resist and its corresponding lateral drift can be found out from the Pushover curve. Most pushover methods adopt a bilinear approximation of the actual push-over curve to obtain an idealized linear response curve,. This is done in such a way that the area under the actual curve will be equal to the area under the bilinear approximate curve.

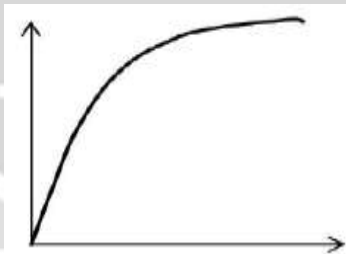

Fig 9: Lateral Load Distribution and a Typical Pushover Curve

4.2 Effect of Confinement Model for Concrete in Lateral Load Behavior It can be seen from the previous Chapter that the effect of confinement significantly change the peak strength and ultimate strain of the stress-strain curve of concrete. In order to study the effect of concrete confinement in the pushover curve, pushover analysis of the 12 storied SMRF frame is conducted by modeling the concrete in the confined core using the two concrete stress-strain models namely, modified Kent and Park model and also the unconfined stress-strain model suggested by IS 456 (2000). Fig. 4.3 shows the pushover curves for the selected frame in both cases. It can be seen that difference in strength between the two pushover curves is only marginal but the change in the displacement capacity is significant. The pushover curve that uses the unconfined stress-strain model underestimates the displacement capacity of 12 storey SMRF frames by 83%. As the accuracy of displacement capacity estimation plays a major role in the estimation of response reduction factors, the SMRF and OMRF frames are modeled by the confinement model and subsequent sections explains the further details.

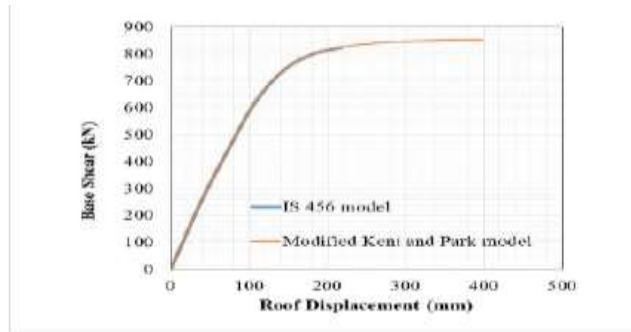

Fig: 10 Effect of confinement in lateral load behaviour of 12 storeyed SMRF frames

No. of storeys	Roof Displacement (mm)		Percentage Increase in Roof Displacement Capacity of SMRF	Base Shear (kN)		Percentage Increase in Base Shear of OMRF
	OMRF	SMRF		OMRF	SMRF	
2	135.82	200.23	47.44 %	569.41	425.5	33.88 %
4	316.02	520.284	64.64 %	689.04	572.4	20.45 %
8	483.369	626.36	29.59 %	876.02	692.8	26.58 %
12	505.212	684.76	35.64 %	914.47	825.87	10.736 %

Table 11: Comparison of strength and deformation capacity for SMRF and OMRF frames

5. Present Study And Scope For Future Work

The present study is limited RC plane frames without shear wall, basement, and plinth beam. The stiffness and strength of Infill walls is not considered. The soil structure interface effects are not taken into account in the study. The flexibility of floor diaphragms is ignored and is considered as stiff diaphragm. The column bases are assumed to be fixed in the study. Open Sees platform (McKenna et al., 2000) is used in the present study. The non-linearity in the material properties are modeled using fiber models available in Open Sees platform.

The present study considered frames with number of storey's varying from two, four, eight and twelve with four number of bays. The aspect ratios of (ratio of height to width) of each frames considered is not the same. The trend of R factors and the components of FR factors show some exceptions in the decreasing trend in some cases. The selection of frames with same aspect ratio may yield variation of R factors with some specific trend. The present study can be extended to frames with same aspect ratios. The present study does not consider the effect of strength and stiffness of infill walls in the frames. This approach can be extended to frames modeling the infill walls.

6. Conclusion

This deals with various confinement models for the stress-strain relationship of concrete. The confinement in the concrete plays a major role in the strength and ductility of the RC members. In order to show the effect of considering the confinement in the stress-strain curve and its effects in the strength and ductility, various sections specially detailed for confinement has to be designed. Hence a number of building frames are considered and designed as both Special Moment Resisting Frames (SMRF) and Ordinary Moment Resisting Frames (OMRF). The configuration of the frames and the reinforcement details of RC sections are also presented in this Chapter. Confinement stress-strain curves for various SMRF and OMREF sections are also developed as per various available models. A review of various confinement models used for the stress-strain relation of concrete is also done later in this Chapter. The details of the building configuration, reinforcement details and the nomenclature assigned

are shown in tabular form. The various existing stress-strain models are studied in-order to evaluate their relative differences in representing the actual strength and deformation behavior of confined concrete.

It has been noted that the stress-strain model suggested by IS 456 does not consider the strength enhancement due to confinement while in reality concrete exhibits different performance in the confined and unconfined conditions. The model proposed by Mander et al (1988a) included the strength enhancement factor achieved through confinement, but it does not control the descending branch of the stress strain curve well. While comparing Razvi model (1992) and Modified Kent and Park model (1982) it was observed that the latter shows higher percentage increase in column capacity and deformation. It was found that many research conducted show that the Modified Kent and Park model is close to the experimental results. In the present study Modified Kent and Park model (1982) has been used. Percentage Strength enhancement due to confinement in Modified Kent and Park model for various column sections is in the range of 32% — 58%. ATC-40 suggested a limiting value of ultimate strain for confined concrete as 0.02. The limiting value of ultimate strain for unconfined concrete is 0.005 as suggested by Priestly (1997).

Reference

- 1) Edmond V. Muho, George A. Papagiannopoulos, Dimitri E. Beskos (2019) A seismic design method for reinforced concrete moment resisting frames using modal strength reduction factors, *Bulletin of Earthquake Engineering*, Volume 17, Issue 1, pp 337–390.
- 2) Ruhullah Amiri, T.N. Patel (2018) Assessment of Seismic Response Reduction Factor According to Redundancy of RC Buildings, *IJSRSET*, Volume 4, Issue 4, ISSN : 2394-4099.
- 3) Prashant R. Barbude, Amol S. Jadhav, Dr.T.N.Boob (2017), Evaluation of response reduction factor for reinforced concrete frames with shear wall, *International Journal of Creative Research Thoughts (IJCRT)*, ISSN: 2320-2882, Pages 606 – 614.
- 4) Aswathy Swaminathan, Prof. Asha Varma P(2017) evaluation of response reduction factor for moment resisting steel frames- A Review, *International Research Journal of Engineering and Technology (IRJET)*, Volume: 04 Issue: 03, e-ISSN: 2395 -0056, Page 1136 – 1140.
- 5) Kunal P Shukla, Sejal P Dalal (2017) Evaluation of Response Reduction Factor of a Reinforced Cement Concrete Building Designed by Performance Based Plastic Design Method and Limit State Design Method, *Science direct vol 127*, page no. 1854- 1861
- 6) Alam, Md. I. and Dookie Kim (2012) Effect of Constitutive Material Models on Seismic Response of Two-Story Reinforced Concrete Frame. *International Journal of Concrete Structures and Materials*, Vol.6, No.2, pp.101-110.
- 7) ASCE 7 (2005) Minimum Design Loads for Buildings and Other Structures. American Society of Civil Engineers. USA.
- 8) Asgarian, B. and Shokrgozar, H.R. (2009) BRBF response modification factor, *Journal of Constructional Steel Research* 65, 290_298.
- 9) Bansal, R. (2011) Pushover analysis of reinforced concrete frame. M.Tech project report. Department of Civil engineering, Thapar University.
- 10) Chandler, A.M. and Mendis, P.A. (2000) Performance of reinforced concrete frames using force and displacement based seismic assessment methods. *Engineering Structures* 22 352–363
- 11) Chugh, R.(2004) Studies on RC Beams, Columns and Joints for Earthquake Resistant Design. M. Tech. Project Report. Indian Institute of Technology Madras, Chennai. India.

- 12) Durga, M.P. and Seshu, R.D. (2013) Effect of Confinement on Load – Moment Interaction Behavior of Reinforced Concrete Column, International Journal of Emerging Technology and Advanced Engineering (ISSN 2250-2459)
- 13) EC 8 (2004) Design of Structures for Earthquake Resistance, Part-1: General Rules, Seismic Actions and Rules for Buildings. European Committee for Standardization (CEN), Brussels. 2004.
- 14) FEMA (2000) Pre-standard and commentary for the seismic rehabilitation of buildings (FEMA-356). Washington (USA): Federal Emergency Management Agency.
- 15) Gioncu, V. (2000) Framed structures ductility and seismic response General Report. Journal of Constructional Steel Research, 55 125–154 2.
- 16) Han, S.W. and Jee, N.Y. (2005) Seismic behaviors of columns in ordinary and intermediate moment resisting concrete frames. *Engineering Structures* 27, 951–962.
- 17) Hoshikuma, J., Kazuhiko, K., Kazuhiro, N. and Taylor, A.W. (1996) A model of confinement effect on stress-strain relation of reinforced concrete columns for seismic design, Eleventh world conference on earthquake engineering.
- 18) IS 13920 (1993) Indian Standard Code of Practice for Ductile Detailing of Reinforced Concrete Structures Subjected to Seismic Forces. Bureau of Indian Standards, New Delhi.
- 19) IS 1893 Part 1 (2002) Indian Standard Criteria for Earthquake Resistant Design of Structures. Bureau of Indian Standards. New Delhi. 2002.
- 20) IS 456 (2000) Indian Standard for Plain and Reinforced Concrete - Code of Practice, Bureau of Indian Standards, New Delhi. 2000.
- 21) Jain, S. K. and Uma, S.R. (2006) Seismic design of beam-column joints in RC moment resisting frames. *Structural Engineering and Mechanics* 23, 5 579-597.
- 22) Jianguo, NIE. V. QIN. Kai, and XIAO Yan. (2006) Push-Over Analysis of the Seismic Behavior of a Concrete-Filled Rectangular Tubular Frame Structure. *Tsinghua science and technology*, ISSN 1007-0214 20/21 pp124-130, Volume 11, Number 1.
- 23) Khose, V.N, Singh, Y. and Lang, D.H. (2012) A Comparative Study of Selected Seismic Design Codes for RC frames Buildings. *Earthquake Spectra* 28, 3.
- 24) Krawinkler, H. and Nassar, A. (1992) Seismic design based on ductility and cumulative damage demands and capacities. In: *Nonlinear seismic analysis of reinforced concrete buildings*, New York, USA. p. 27–47.
- 25) Varghese, V. and Borkar, Y.R. (2013) Comparative Study of SMRF Building over OMRF Building with Seismic and Wind Effect. *International Journal of Engineering Research and Applications*. Vol. 3, Issue 3, pp.1501-1503.25)
- 26) Sharma, A., Reddy, G., Vaze, K., Ghosh, A. and Kushwaha, H. (2009) Experimental investigations and evaluation of strength and deflections of reinforced concrete beam column joints using nonlinear static analysis. Technical report. Bhabha Atomic Research Centre; Mumbai, India.