

# ENHANCING QoS USING ROBUST BANDWIDTH ALLOCATION SCHEDULING ALGORITHMS OVER WIMAX NETWORKS

Anil Kumar\* , Jagbir Singh #

\* Dept. of Computer Science and Engg.

CGC College of Engg., Landran, Mohali (Punjab), India

# Asst. Professor, Dept. of Computer Science and Engg.

CGC College of Engg., Landran, Mohali (Punjab), India

## ABSTRACT

The wireless medium has limited bandwidth, higher packet error rate, and higher packet overheads that altogether limit the capacity of the network to offer guaranteed QoS. OFDM systems, also referred as Multi-carrier Systems, are known to be the basis of 3G and 4G technology, for example in LTE (Long Term Evolution) 4G cellular standards, WiMAX Standards, 802.11 a/g/n Microwave standards, etc. Thus OFDM is a key wireless broadband technology which supports high data rates. Despite of several advantages of this technique, OFDM suffers from a high PAPR which degrades BER performance and results in loss of orthogonality. In this paper, we provide a simulation based evaluation of the cyclic prefixes (Conventional/ Turbo) against various service classes and adaptive QoS scheduling classes that are the key functions in the MAC common part sub layer.

**Keyword** : - CCDF, Clipping, OFDM, PAPR, Precoding, Windowing.

## I. INTRODUCTION

Multiple access techniques are used to provide access to a large number of users within same bandwidth. Of all multiple access techniques, OFDM has emerged out as a popular scheme to be used in several applications such as digital audios & videos, broadband systems, wireless networking, 3G and 4G standards and WiMAX [1]. In Orthogonal Frequency Division Multiple access scheme total bandwidth available is divided into smaller non-overlapping frequency sub-bands. Usually a separate data signal is associated to each frequency sub-band. Two periodic signals are said to be orthogonal when the integral of their product over one period is equal to zero. Mathematically, orthogonality for two periodic signals can be represented as:

$$\int_0^T \cos(2\pi nft) \cos(2\pi mft) dt = 0 \quad \dots (1) \quad \sum_{k=0}^{N-1} \cos\left(\frac{2\pi kn}{N}\right) \cos\left(\frac{2\pi km}{N}\right) = 0 \quad \dots (2)$$

where  $m \neq n$  and equation (1) represents the condition for orthogonality for continuous signals while equation (2) represents condition for orthogonality for discrete signals.

**1.1 Basics of OFDM:** In OFDM typically PSK or QAM modulation schemes are used in OFDM systems. An OFDM signal can be generated by an N-point inverse FFT in transmitter and FFT is performed at the receiver to restore the original data. IFFT performs the transformation efficiently and ensures the orthogonality of sub-carriers. It also reduces the number of computations as it allows setting the un-used carriers to zero. Complexity of OFDM system is largely determined by IFFT points. More IFFT points demands more power but enhances resolution.

**1.2 OFDM Model:** In OFDM basic model is shown in fig (1) depicted below. The first and foremost step is to divide data into several parallel data streams or channels such that one parallel block of data has its own unique sub-carrier. Then each sub-carrier is modulated at low symbol rate using conventional modulation schemes preferably QAM or PSK modulation techniques such that the total data rates are maintained similar to conventional single-carrier modulation scheme in same Bandwidth. The bandwidth of sub-carriers is small compared to the Bandwidth of the channel [7].

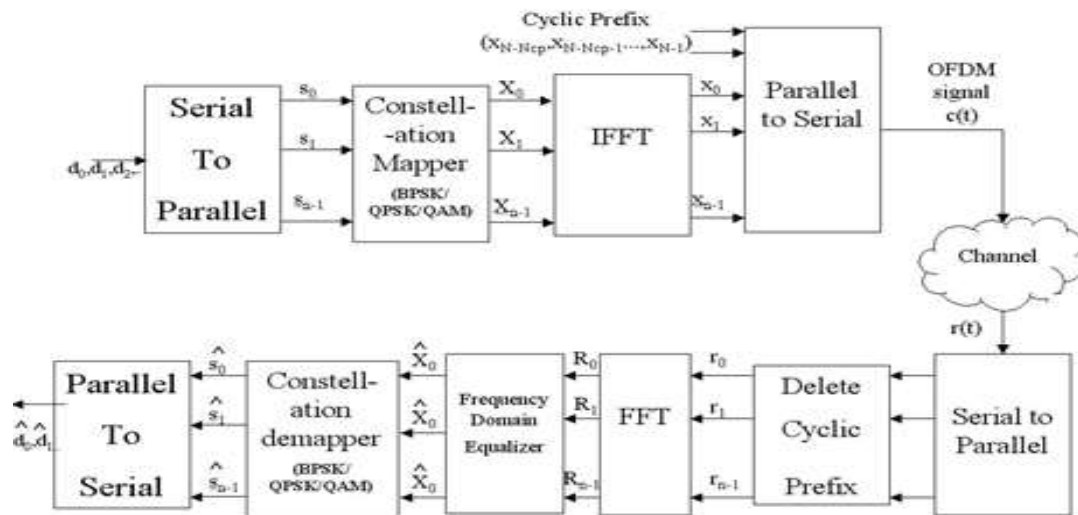

Figure 1: Functional stages of a WiMAX PHY layer

This implies that the symbol period of sub-bands is higher than the delay spread of radio channel. This is the required condition for low interference, that is, no interference will if the symbol period of sub-band is larger than the delay spread. Also, guard bands are inserted between the adjacent sub-bands to eliminate Inter-Symbol Interference. However, it is important to note here that the Guard time is purely system overhead. After the modulation or constellation mapping, IFFT is performed on the data symbols and cyclic prefix is added [7]. The cyclic prefix is actually used to preserve the orthogonality of the sub-carriers. It also provides multipath immunity and synchronization tolerance but it consumes some transmission bandwidth hence results in lower spectral efficiency. Similar to Guard bands, the transmit power associated with the cyclic prefix is a waste. At the receiver, the received data is first converted from serial to parallel form and cyclic prefix is removed. After this the FFT operation is performed and data is de-modulated and converted back in original form.

**1.3 Representation of OFDM signals:** Let a block of N symbols  $X_N = \{ X_k \}$  where  $k = (0, 1, \dots, N - 1)$  is formed with each symbol modulating the corresponding sub-carrier from a set of orthogonal sub-carrier where  $X_k$  is the symbol carried by the  $k^{th}$  sub-carrier. Therefore, the discrete-time complex OFDM symbol can be written as:

$$X(n) = \frac{1}{\sqrt{N}} \sum_{k=0}^{N-1} X_k e^{j\frac{2\pi kn}{N}}, \quad 0 \leq n \leq N - 1 \dots\dots (3)$$

The equation consists of N independently modulated sub-carriers. There are various factors which make OFDM a popular scheme such as spectral efficiency, modulation & demodulation using FFT techniques, less sensitivity to sample timing offsets, superior performance over frequency selective channels and protection against co-channel interference. Regardless of these many advantages, OFDM application is limited by various concerns such as sub-band spacing, interference, frequency offset, timing offset and high PAPR. In wireless systems, high PAPR ratio causes lots of problem in data transmission and reception.

**2. PEAK-TO-AVERAGE-POWER RATIO**

Peak-to-Average Power Ratio occurs when N signals are added with same phase due to which they produce a peak power that is N times the average power. In other words, a number of independently modulated sub-carriers result in High-PAPR which means there is a significant deviation of instantaneous power or peak power about the mean. From equation (3), it could be observed that N modulated sub-carriers give a large number of PAPR when added up coherently. Mathematically, PAPR is given as:

$$PAPR = \frac{\text{Maximum Power}}{\text{Average Power}} \dots\dots (4)$$

$$= \left[ \frac{\max |x(n)|^2}{E\{|x(n)|^2\}} \right] \dots\dots (5)$$

Equation in the denominator of equation (5) represents Expectation Operator. PAPR increases with the number of sub-carriers. Reducing  $\max |x(n)|$  is the principle goal of any PAPR reduction technique.

In OFDM because of IFFT pre-processing, the instantaneous swings of transmitted symbols over the average level is actually enhancing. Because different symbols are loaded onto sub-carriers are random and depending on their nature, they can occasionally all add up across the sub-carriers to produce a high peak value which gives rise to a very instantaneous swing with respect to the mean value. PAPR leads to a necessity of using circuits and hardware with linear characteristics or dynamic range; otherwise the signal clipping at high levels would yield a large distortion of transmitted signal and out-of-band radiation.

**2.1 Problems due to PAPR:** A high PAPR ratio results in many problems. Some of the major problems are non-linear distortion of High Power Amplifier, degradation in BER performance, energy splitting into adjacent channels, inter-modulation effects on sub-carriers, warping of signal constellation in each sub-channel, increased complexity in ADC and DAC operation, reduced efficiency of RF power amplifier and loss of orthogonality between sub-carriers. To understand this problem in detail, one needs to understand every component of the transmitter. Let us consider the amplifier characteristics. It has two major sections: linear range and non-linear region. For non-linear region we say that the amplifier is saturated. Typically amplifier is biased around a certain operating point in the linear or dynamic range. As long as the signal swings limited to this dynamic range, input and outputs are linearly related. That is, around this mean if the deviation is not extremely large but the deviation of voltage is small, then the signal is still confined to the linear amplification range. However in OFDM systems, the peak can swing very high compared to mean which crosses over to the non-linear range. Thus, because practically we use non-ideal amplifiers which are limited by the linear amplification range and the swing of peak power can be very high compared to the mean; it crosses over in to the non-linear range that result in non-linear amplification. Once the amplification is non-linear, all the properties of OFDM cease to hold such as orthogonality is lost, severe interference and so on. As the peak distortion increases, the inter-carrier interference increases which means that the significant distortion and inter-carrier interference occurs because there is a loss in signal-to-noise power ratio. In other words, if the peak deviation about the average (mean) is significantly high then the signal level moves outside the dynamic linear range.

**2.2 SCFDMA as a possible solution:** SCFDMA is a variant of OFDMA and it stands for single-carrier FDMA. It is a technique which is employed in 4G LTE to reduce PAPR specifically. To understand let us look at typical OFDM transmitter.

**Modified Model:**

In the modified model, first the M-point DFT is performed on the modulated data symbols. These M-point DFT symbols are then mapped to N-point IFFT in the transmitter block. At the receiver, first the N-point DFT is performed along with Frequency domain equalization and then M-point IDFT is performed with demodulation and parallel to serial converter. Other sub-sections are similar to the basic OFDM transmitter and receiver. The modified model for SC-FDMA is represented in the figure below showing blocks similar to OFDM and additional blocks to make a complete SC-FDMA modified model.

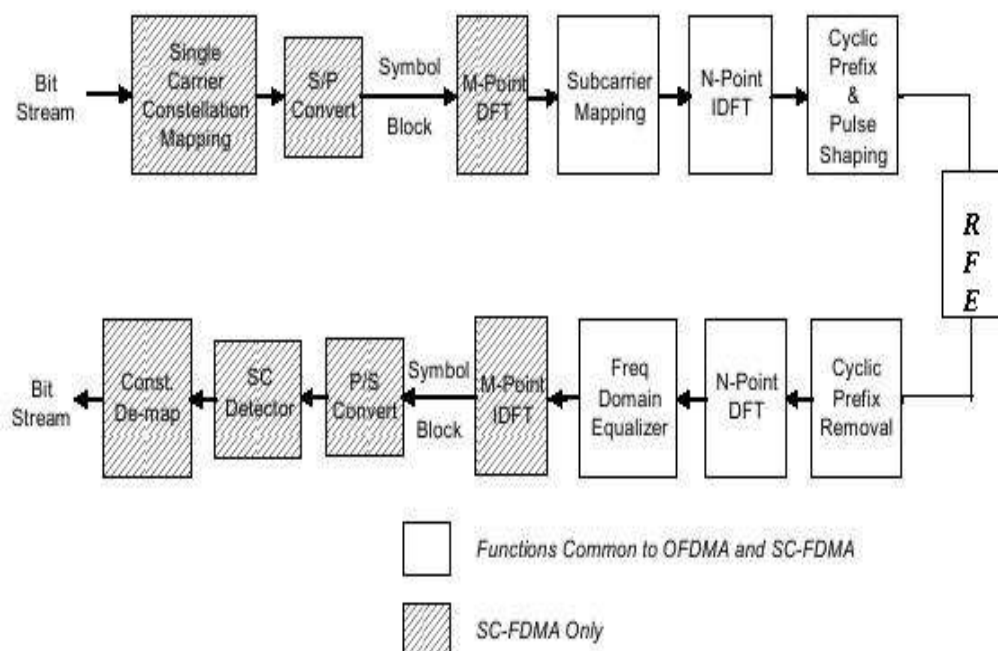

**Figure 2:** modified model for M-point DFT.

As in the above transmitter model we can see, FFT and IFFT are inverse to each other. So they cancel out each other's effect. This means whatever serial symbols inputted are the same symbols that are coming at the output except for the addition of cyclic prefix. So the output here is essentially a single carrier output which means PAPR is close to 0dB or PAPR is close to 1 or 0 dB. Since the single carrier system suffers from ISI, hence we do not perform exactly N point FFT but some M point FFT where M is slightly smaller than N. As a result the system does not move completely towards a single carrier system but retains some properties of OFDM as well as reduced PAPR. Therefore, to achieve a trade off what can be done is by using N FFT block which converts the system into a single carrier system. The modification is done such that the system do not completely transforms to a single carrier system and retains the properties of OFDM also.

## II. QoS ARCHITECTURE IN WiMAX NETWORKS

The WiMax Forum's Network Working Group [3], is responsible for developing the end-to-end network requirements, architecture, and protocols for WiMax, using IEEE 802.16e-2005 as the air interface. The network reference model envisions unified network architecture for supporting fixed, nomadic, and mobile deployments and is based on an IP service model. Figure 1.8 shows a simplified illustration of IP-based WiMax network architecture. [2] The overall network may be logically divided into three parts:

**Mobile Station (MS):** It is for the end user to access the mobile network. It is a portable station able to move to wide areas and perform data and voice communication. It has all the necessary user equipments such as an antenna, amplifier, transmitter, receiver and software needed to perform the wireless communication. GSM, FDMA, TDMA, CDMA and W-CDMA devices etc are the examples of Mobile station. Mobile stations used by the end user to access the network.

**Access Service Network (ASN):** It is owned by NAP, formed with one or several base stations and ASN gateways (ASN-GW) which creates radio access network. It provides all the access services with full mobility and efficient scalability. Its ASN-GW controls the access in the network and coordinates between data and networking elements. ASN comprises one or more base stations and one or more ASN gateways that form the radio access network at the edge.

**Connectivity Service Network (CSN):** Provides IP connectivity to the Internet or other public or corporate networks. It also applies per user policy management, address management, location management between ASN, ensures QoS, roaming and security. CSN provides IP connectivity and all the IP core network functions.

The architecture allows for three separate business entities:

- i. Network access provider (NAP), which owns and operates the ASN;
- ii. Network services provider (NSP), which provides IP connectivity and WiMax services to subscribers using the ASN infrastructure provided by one or more NAPs;
- iii. Application service provider (ASP), which can provide value-added services such as multimedia applications using IMS (IP multimedia subsystem) and corporate (virtual private networks) that run on top of IP.

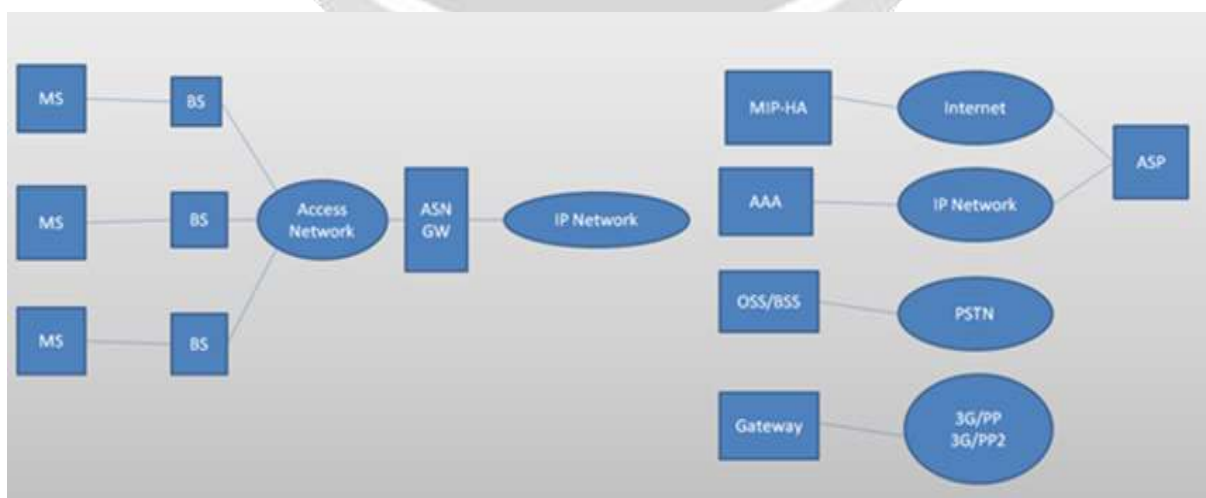

Figure 3: WiMax architecture based on IP [12].

The IEEE 802.16 standard supports both point-to-point (PP) and point-to-multipoint (PMP) topologies, and an optional mesh configuration. In a fixed PMP WiMAX network, a BS communicates with multiple stationary SSs, as shown in Figure 2. The MAC of a PMP WiMAX network is centrally managed by the BS, which offers connection-oriented services to individual traffic flows. Each traffic flow is uniquely identified by a connection identifier (CID), and belongs to one of the listed QoS classes, which are defined at the WiMAX MAC layer [13] to provide differentiated traffic treatment.

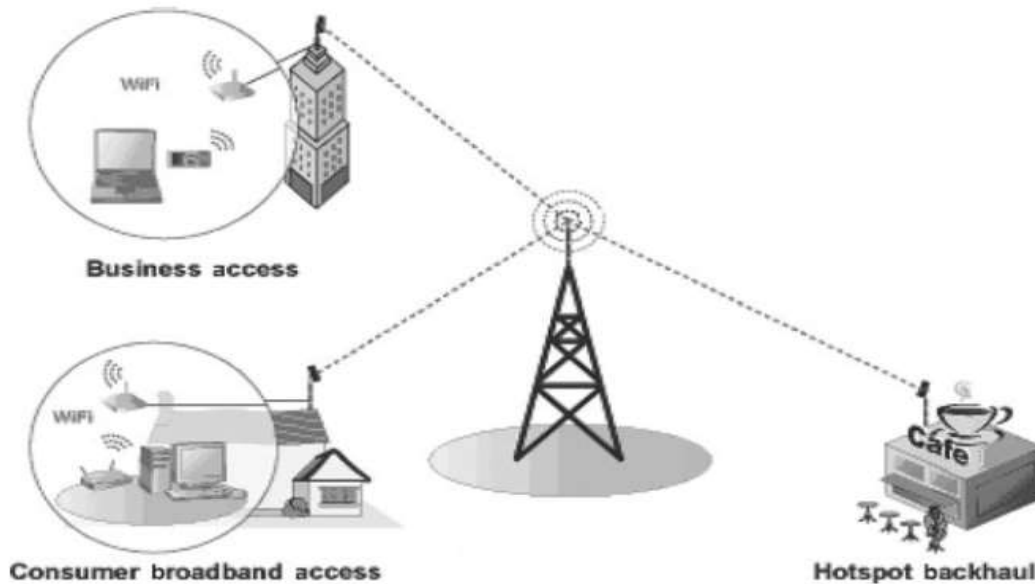

Figure 4 : Point to Multipoint Wimax Network [13].

#### CHANNEL CODING:

In IEEE 802.16e-2005, the channel coding stage consists of the following steps:

- (1) data randomization,
- (2) channel coding,
- (3) rate matching,
- (4) Hybrid ARQ, if used,
- (5) and interleaving.

Data randomization is performed in the uplink and the downlink, using the output of a maximum length shift-register sequence that is initialized at the beginning of every FEC block. This shift register sequence is modulo 2, added with the data sequence to create the randomized data. The purpose of the randomization stage is to provide layer 1 encryption and to prevent a rogue receiver from decoding the data. When HARQ is used, the initial seed of the shift-register sequence for each HARQ transmission is kept constant in order to enable joint decoding of the same FEC block over multiple transmissions. Channel coding is performed on each FEC block, which consists of an integer number of *Sub-channels* and comprises several data and pilot subcarriers. [1] The maximum number of sub-channels in an FEC block is dependent on the channel coding scheme and the modulation constellation.

- **Convolutional Coding:** The mandatory channel coding scheme in IEEE 802.16e-2005 is based on binary non recursive convolutional coding (CC). The convolutional encoder uses a constituent encoder with a constraint length 7 and a native code rate  $\frac{1}{2}$ . The output of the data randomizer is encoded using this constituent encoder. In order to initialize the encoder to the 0 state, each FEC block is padded with a byte of 0x00 at the end in the OFDM mode. The 6 bits from the end of the data block are appended to the beginning, to be used as flush bits. These appended bits flush out the bits left in the encoder by the previous FEC block. The first 12 parity bits that are generated by the convolutional encoder which depend on the 6 bits left in the encoder by the previous FEC block are discarded.

- **Turbo Codes:** Several optional channel coding schemes such as block turbo codes, convolutional turbo codes, and low density parity check (LDPC) codes are defined in IEEE 802.16e [9]. WiMax uses duo binary turbo codes with a constituent recursive encoder of constraint length 4. In duo binary turbo codes two consecutive bits from the un-coded bit sequence are sent to the encoder simultaneously, the duo binary convolution encoder has two generating polynomials,  $1+D^2+D^3$  and  $1+D^3$  for two parity bits. Since two consecutive bits are used as simultaneous inputs, this encoder has four possible state transitions compared to two possible state transitions for a binary turbo encoder.

### III. RELATED WORK

In this paper, Simulations are performed for two popular scheduling algorithms under mandatory channel codes namely  $1/4$ ,  $1/18$ ,  $1/16$ ,  $1/32$  over IEEE 802.16 based dynamic environment. The impact of optional channel coding in Effect of Binary Phase Shift Key modulation scheme on the performance of two schedulers namely real time Polling Service (rtPS), Non-real time Polling service (nrtPS) is shown with the help of graphs in terms of throughput, amount of packets delivered and end-to-end delay.

**Number of Packets delivered :** Figure 5 shows the amount of packets successfully delivery at base station wfor different Conventional/ Turbo channel codes under varying WiMAX MAC schemes. Simulation results shows nrtPS and rtPS gives higher performance when Turbo channel code is higher. Comparision of simulation results depicts that rtPS gives better performance than nrtPS for hihger value of channel code i.e  $1/32$ .

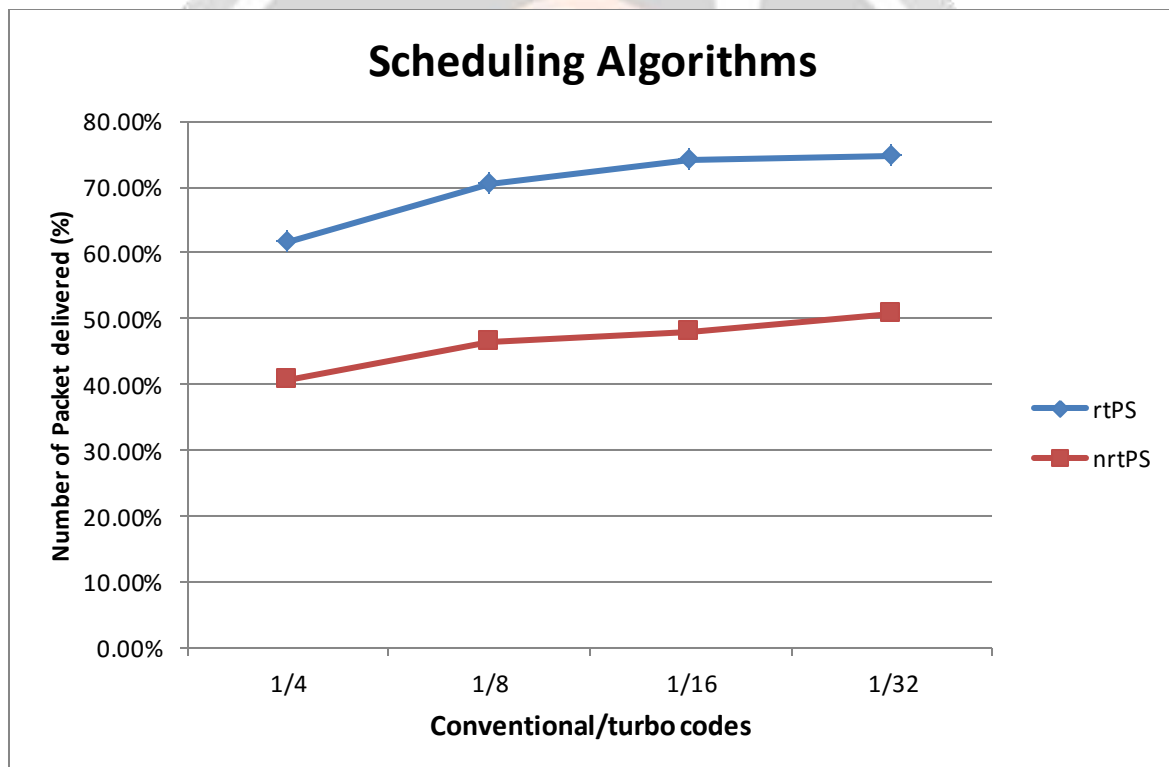

**Figure 5:** Number of Packets Delivered versus Conventional/ Turbo codes.

**Throughput :** The figure 6 shows the impact of conventional/turbo codes on the throughput for two different MAC-scheduler schemes. It is observed from simulation graphs that the throughput of rtPS scheme is better than nrtPS scheme under different channel coding rates.

Figure 7, tell about the Non real time polling service flow support between base- station and subscribers under varying time intervals. It is observed from simulation graphs that the throughput of MAC level QoS scheduling schemes will be enhanced using higher levels of channel coding rate. Comparision of the graphs depicts that rtPS scheduler under  $1/32$  channel coding rate performance better.

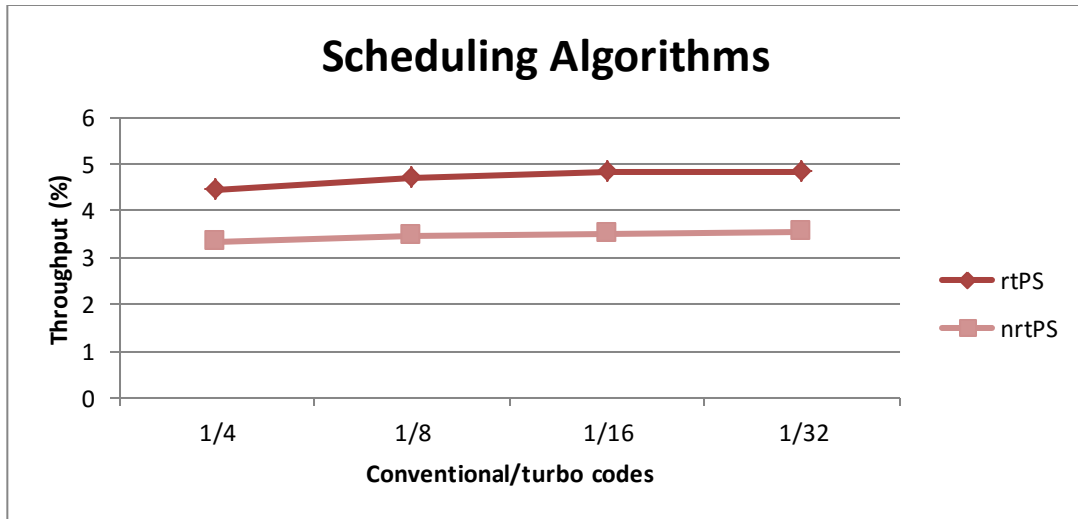

Figure 6: Throughput versus Conventional/ Turbo codes.



Figure 7: Real time polling service v/s time intervals.



Figure 8: Non-real time polling service v/s time intervals.

#### IV. CONCLUSION

WiMAX networks promise to offer an easy deployable and relatively low cost solution for the wireless broadband access. In usual operating conditions, WiMAX will likely support traffic belonging to a wide range of broadband applications, and it is claimed to provide differentiation among heterogeneous demanding flows. Channel encoding and QoS services classes are the key components to provide QoS capability and proportional fairness in the bandwidth sharing over a changing radio environment. The simulation results were presented for real time Polling and non real time Polling services under channel coding rate [1/4, 1/8, 1/16 and 1/32]. From the simulation results it is observed that real time Polling service control under higher coding rate 1/32, has best performance as compared to lower channel coding rates.

Further in this direction our aim is to compare the performance of these schedulers against other available QoS MAC-scheduler schemes for different the signal to noise and modulation techniques and some more metrics like packets dropped, routing message overheads, good put are still to be considered.

#### REFERENCES

- 1) T. Jiang, W. Xiang, H. H. Chen, and Q. Ni, "Multicast broadcasting services support in OFDMA -based WiMAX systems," IEEE Communications Magazine, vol. 45, no. 8, pp. 78–86, Aug. 2007.
- 2) Gross, R. and D. Veeneman, "Clipping distortion, in DMT ADSL systems," IEEE Electron. Letter, Vol. 29, 2080–2081, Nov. 1993.
- 3) Davis, J. A. and J. Jedwab, "Peak-to-mean power control in OFDM, Golay complementary sequences, and Reed-Muller codes," IEEE Trans. Inform. Theory, Vol. 45, 2397–2417, Nov. 1999.
- 4) Muller, S. H. and J. B. Huber, "OFDM with reduced peak-to average power ratio by optimum combination of partial transmit sequences," IEEE Electron. Letter, Vol. 33, 368–369, Feb. 1997.
- 5) Yung, C., K. Shang, C. Kuan, and C. Mao, "Turbo coded OFDM for reducing PAPR and error rates," IEEE Transactions on Wireless for Communications, Vol. 7, No. 1, Jan. 2008
- 6) Tao Jiang, Yiyang Wu, "An overview: Peak-to-Average Power Ratio Reduction Techniques for OFDM Signals." IEEE Transactions on Broadcasting, Vol. 54, NO. 2, JUNE 2008.
- 7) Prasad Ramjee, OFDM for Wireless Communication Systems. (Artech House, Inc. Boston, London, 2004)
- 8) Le Goff, Boon Kien Kho, Tsimenidis, Sharif B.S., "A Novel selected mapping technique for PAPR reduction in OFDM systems", IEEE Transactions on Communications, Vol. 56, Nov. 2008.
- 9) Rakesh Kumar Jha, Idris Z. Bholebawa, Upena D. Dalal, "Location Based Performance of WiMAX Network for QoS with Optimal Base Stations (BS)", Wireless Engineering and Technology, [Volume 2, No.3, July 2011](#).
- 10) L.D. Malviya A. Gaiwak Dr. P.D. Vyavhare, "Simulation based comparison of different Modulation schemes for Mobile WiMAX using TCP and its Variants", 978-0-7695-3267-7/08 \$25.00 © 2008 IEEE DOI 10.1109/ICETET.2008.191 First International Conference on Emerging Trends in Engineering and Technology.
- 11) Shraddha Bansal, Raksha Upadhyay, "Performance Improvement of Wi-Max IEEE 802.16e in Presence of Different FEC Codes", CICSYN, IEEE, 2009.
- 12) T Anouar and Abdelkrim Haqiq, "Performance Analysis of VoIP Traffic in WiMAX using various Service Classes" International Journal of Computer Applications, volume -20, pp. 29-33, August 2012.
- 13) Chenn-Jung Huang et al "A Bluetooth routing protocol using evolving fuzzy neural network" international journal of wireless information network vol. 11, no3, July 2004.