

Energy Analysis of 12.5 MW Co-generation plant at Porbandar

¹ MILAN PANKHANIYA, ² AKASH SHUKLA,
³ ASHUTOSH JOSHI, ⁴ HARDIK PANELIYA

^{1,4} Lecturer in Mechanical Engineering Department, Atmiya Institute of Technology & Science, Rajkot, Gujarat-India

ABSTRACT

The point of this project is to utilize the energy analysis in view of the first law of thermodynamics to recognize the areas and magnitudes of losses with a specific end goal to boost the execution of a 12.5 MW plant at Nirma organization ltd., Porbandar, to assess the general plant, heater, and turbine and subsystem inefficiencies. Energy flows in a boiler have been appeared in this paper. The heater proficiency is figured utilizing backhanded strategy in the wake of evaluating the different warmth misfortunes in the boilers. From results the general heat losses of the plant by processing the individual proficiency of the boiler (78.85%), steam turbine (35.75%), and generator (95%). The general proficiency of the plant seems, by all accounts, to be 25.78 %

Keywords—Energy, Boiler Efficiency, Extraction back-Pressure Turbine.

1: INTRODUCTION

Energy is one of the major inputs for the economic development of any country. The overall power scene in India shows heavy shortages in almost all the states. Today, many electrical generating utilities are striving to improve the efficiency (or heat rate) at their existing thermal electric generating stations, many of which are over 25 years old. Often, a heat rate improvement of only a few percent appears desirable as it is thought that the costs and complexity of such measures may be more manageable than more expensive options. To assist in improving the efficiencies of coal-to-electricity technologies, their thermodynamic performances are usually investigated. In general, energy technologies are normally examined using energy analysis. The primary objective of energy efficiency measures in the industry is to lower energy cost by reducing the need for purchased energy or by using least-cost energy resources. Cogeneration, being one of the energy conservation methods, offers good scope, especially in process industries, for attaining higher efficiency levels.[1] The increased awareness that the world's energy resources are limited has caused many countries to re-examine their energy policies and take drastic measures in eliminating waste. The first law analysis is used to assess the overall plant performance. It has also sparked interest in the scientific community to take a closer look at the energy conversion devices and to develop new techniques to better utilize the existing limited resources (Cengel and Boles, 2008). Nowadays, there are a few methods to measure the performance of a power plant (Hussein et al., 2001). [2] Thermodynamically, it is established that the thermal efficiency of the plant increases with an increase in the maximum cycle temperature. However, if the maximum cycle temperature increases, the exhaust temperature also increases, thereby increasing the loss of heat to the environment.

2: WHAT IS COGENERATION?

2.1 Extraction back-pressure turbine type:

This is performed on that the extraction of steam for heat generation is not taken from the rear part but from the middle part of the turbine. This has the advantage that heat and power generation can be adjusted to the different requirements. With the help of valves the extraction pressure can be adjusted right at the extraction point so that the required steam conditions for heat generation can also be kept when run at part load. This is the advantage over the topping steam turbine where the conditions vary according to the load point.[8] To meet the demands of high heat requirements all steam for heat generation can be taken from the extraction point. Depending on the pressure (or temperature) levels at which process steam is required, backpressure steam turbines can have different configurations as shown in Figure 1. In extraction and double extraction backpressure turbines, some amount of steam is extracted from the turbine after being expanded to a certain pressure level. The extracted steam meets the heat demands at pressure levels higher than the exhaust pressure of the steam turbine.

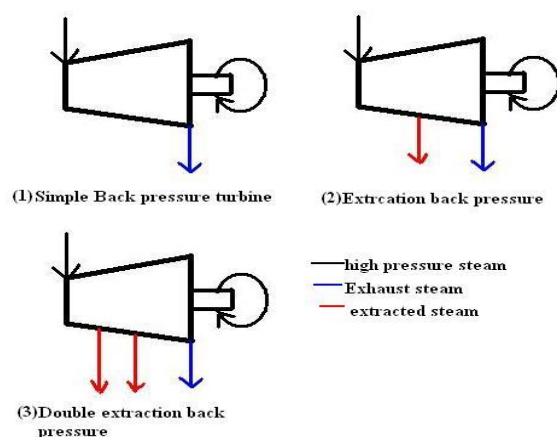

Fig 1 Different Configurations for Back Pressure Steam Turbines

2.2 Application:

Cogeneration systems are also quite suitable for various process industries involving rayon, pulp and paper, chemical process, textile and fertilizer, where both power and process steam are used. When a constant amount of heat is required (because of little possibilities of control) Very often there are various steam turbines arranged on a line in order to allow using one or more turbines according to the requirements. [3]

2.3 Extraction condensing turbine:

The functionality is similar to that of a cycle with back pressure turbine with the difference that here the extraction steam for heat generation is not taken from the rear part but from the middle part of the turbine. This has the advantage that heat and power generation can be adjusted to the different requirements. With the help of valves the extraction pressure can be adjusted right at the extraction point so that the required steam conditions for heat generation can also be kept when run at part load. This is the advantage over the topping steam turbine where the conditions vary according to the load point. [5]

3. DESCRIPTION OF COGENERATION POWER PLANT

The Steam turbine cogeneration plant, chosen for the present study consists of two steam turbine units total 25 MW power output and two CFBC boiler with capacity of 120 TPH steam flow rate each one. Figure 1 shows the schematic layout of the plant. Each ST unit has an installed capacity of 12.5 MW and each boiler unit has the capacity to generate process heat as 120 TPH of HP steam at $105 \text{ kg/cm}^2 \text{ g}$ and 90 TPH of LP steam at $31.5 \text{ kg/cm}^2 \text{ g}$.

3.1 Plant operation:

A schematic diagram of the plant with its various significant components, considered for the present study is shown in figure 1. The demineralized water from the DM tank enters the boiler drum using boiler feed pumps. This DM water then passes through the bank tubes where it is converted into steam and flows through the turbine on reaching to the desire temperature and pressure. The water is converted into steam using the heat energy of the fuel used in combustion process. Lignite coal used as a fuel. After combustion of fuel, gases are generated which after exchanging heat through the water wall tube escapes from the stack. The steam after passing through the turbine goes to extraction and last to the exhausted to process industry. The process is repeated again wherein, the condensed steam is sent back to the upper drum using feed water pumps. The turbine rotates using the steam and the generator is connected through gear box rotates which in turn leads to generation of electricity. This electricity is then transmitted through the transmission lines. the steam extracted from the various points is also shown in the schematic diagram. [9]

Table 1 Working Data of 12.5MW Cogeneration Power Plant

Content	Unit	Value
Load	MW	12.5
Coal Flow	TPH	28
Steam flow	TPH	90
FW pressure before economiser	Kg/cm ² .g	107
FW temp before economiser	°C	125
FW temp at Eco outlet	°C	306
O ₂ in APH inlet	%	4
O ₂ in APH outlet	%	4.5
Superheated steam temp	°C	505
Superheated steam Pressure	Kg/cm ² .g	105
CO ₂ in flue gas	%	14
CO in flue gas	%	0.6
FW flow	TPH	95
LP steam to dearetor temp	°C	133
Temperature of water at dearator outlet	°C	123
Flue gas inlet to APH	°C	144
Flue gas at stack	°C	102
Flue gas inlet to economizer	°C	320
Flue gas at outlet of super heater	°C	667
Hot air from APH	°C	220

Table 2 Coal specifications

Parameter	Kutch Lignite coal	Imported coal
GCV (Kcal/Kg)	3380	6200
Ash content (%)	10.8	10
Moisture (%)	34	13.27
Sulphur content (%)	2.5	0.4
Oxygen (%)	12.5	8.2
Carbon (%)	36.5	62.5
Hydrogen (%)	2.5	4.39

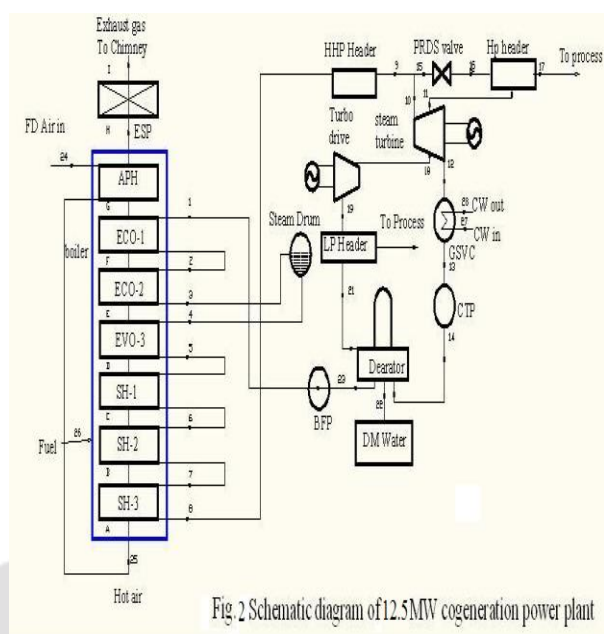

Figure 2 Schmetic diagram of 12.5MW cogeneration plant

4. ENERGY ANALYSIS

The first law of thermodynamics (Energy analysis) deals with the quantity of energy and asserts that energy cannot be created or destroyed. The law merely serves as a necessary tool for the bookkeeping of energy during a process and offers no challenges to the engineer (Ganapathy *et al.*, 2009; Makinde, 2008; Cengel and Boles, 2008). Energy is always conserved (in balance); it can neither be produced nor consumed. Energy is a measure of quantity (Dincer and Al-M uslim, 2001). The First Law deals with the amounts of energy of various forms transferred between the system and its surroundings and with the changes in the energy stored in the system. It treats work and heat interactions as equivalent forms of energy in transit and offers no indication about the possibility of a spontaneous process proceeding in a certain direction. The first law places no restriction on the direction of a process, but satisfying the first law does not ensure that the process can actually occur. This inadequacy of the first law to identify whether a process can take place is remedied by introducing another general principle, the second law of thermodynamics. Energy analysis of a thermal system is based on the first law of thermodynamics which embodies the following two distinct assertions: A system can interact with its surroundings in only one direction. There is a property called energy whose change gives It is important to note that for conservation of energy it is necessary to pursue two objectives, namely to reduce the demand for energy and to supply this demand at the maximum possible efficiency. The second objective is within the field of the engineering community. The first law efficiency of a thermal system, which is the ratio of the work output to the heat input, has shortcomings. For example: It cannot be readily generalized to complex systems in which the desired output is a combination of work and heat, as in total energy systems. It completely ignores the exergy concept which plays the central role in governing utilization and conservation of fuel resources. It does not provide any suitable guidance for fuel loss minimization and thus leads to wrong conclusions in terms of fuel economy [6].

5. RESULT ANALYSIS AND DISCUSSION

The data for boiler operation and turbine operation of TPS at full load were observed and relevant parameters have been estimated. Using these data and compiled value, First law analysis (energy analysis) is carried out for the given plant. The performance of a plant is evaluated by calculating the overall efficiency of unit by using the individual efficiencies of boiler, turbine and generator. The performance of a plant is evaluated by calculating the individual efficiencies of the boiler, turbine and generator. The efficiency of the boiler is evaluated by indirect method. In the indirect method the input is assumed to be 100% and the various losses encountered in the boiler are calculated and subtracted from 100. The various losses in the boiler are; energy losses due to exhaust gas, energy losses due to hydrogen in fuel, energy losses due to moisture in fuel, energy losses due to moisture coming with air supplied, energy losses due to partial conversion of C to CO, energy losses due to

unburnt in fly ash & bottom ash, and radiation, convection. [7] Based on the data available in table 1, the calculations are made for boiler losses and the results are shown in table 4. From the available data for the turbine, following calculations are made to calculate the turbine efficiency. Turbine inlet steam flow = 90 TPH = 25 kg/s.

$$\begin{aligned} \text{Heat Input to Turbine} &= m_S \times (h_S - h_{FW}) + m_{DS} \times (h_{\text{inlet}} - h_{FW}) \\ &= 25 \times (3379.7 - 516.31) + 1.11(2734 - 139.16) \\ &= 71584 + 2880.27 \\ &= 74464.27 \text{ KJ/kg} \end{aligned}$$

$$\eta_T = \frac{\text{Power generation}}{\text{heat input to turbine}}$$

$$\begin{aligned} &= \frac{25 \times 1000}{74464.27} \\ &= 35.75 \% \end{aligned}$$

Overall thermal efficiency = boiler efficiency × turbine efficiency × generator efficiency

$$\begin{aligned} \eta_o &= 78.85 \times 35.75 \times 95 \\ &= 25.78 \% \end{aligned}$$

Table 3 Different efficiencies of power plant

Sr no	Component	Efficiency (%)
1	Boiler	78.85
2	Turbine	35.75
3	Generator	95
4	Overall efficiency	25.78

Table 4 Summary of Heat Balance for Coal Fired Boiler

Parameter	Kcal/kg of coal	(%)
Heat input	3380	100
Losses in Boiler	223.08	6.60
Energy losses due to the exhaust gas	241.33	7.14
Energy losses due to hydrogen in fuel	147.36	4.36
Energy losses due to moisture in fuel	222.74	6.59
Energy losses due to moisture coming with air supplied	9.126	0.27
Energy losses due to partial conversion of C to CO	59.48	1.76
Energy losses due to radiation & convection	67.6	2
Energy losses due to unburnt in fly ash	4.90	0.145
Energy losses due to unburnt in bottom ash	7.77	0.23
Total losses		79.499

6. CONCLUSION

From the above experiment & result analysis it is very clear that CFBC boiler efficiency is highest, which is 78.85% and the heat losses are only 21.15%. Out of all the boiler losses, the highest heat losses 7.14% occurs due to the exhaust gas.

The turbine efficiency is very less and is estimated as 35.75% Because of the several turbine losses like; Losses in regulating valve, Nozzle friction losses, Blade friction losses, Disc friction losses, Partial admission losses, Gland leakage losses, Carry over losses.

From the thermodynamic analysis using first law of thermodynamics, we can conclude that, energy analysis evaluates the plant quantitatively. The power plant overall efficiency is 25.78%.

7. FUTURE WORK

In the future work performance analysis will be carried out at Saukem Ltd, Porbandar using plant operational data to evaluate the energy, exergy efficiency of plant, along with heat loss and exergy loss occurs in each component of plant. For that mass flow rate, pressure and temperature of each component are considered for the performance analysis of lignite coal based 12.5 MW cogeneration power plant.

8. ACKNOWLEDGMENTS

We are very much thankful to peoples of Nirma cogeneration power plant for providing sufficient data for plant. We are also thankful to those who help directly or indirectly to complete the project

9. REFERENCES

- [1] T. Ganapathy, N. Alagumurthi, R.P. Gakkhar, Exergy Analysis Of Operating Lignite Fired Thermal Power Plant, Journal Of Engineering Science And Technology Review 2(1), 123-130, [2009].
- [2] R.K. Kapooria, S. Kumar, K.S. Kasana,, "An Analysis Of A Thermal Power Plant Working On A Rankine Cycle A Theoretical Investigation", Journal Of Energy In Sourthen Africa, Vol 19(1), February [2008], 77-82.
- [3] Nag, P. K., "Power Plant Engineering,", Tata McGraw Hill, New Delhi, 2nd Edition, [2001].
- [4] El-Wakil, M. M., "New Power Plant Technology", New York, McGraw-Hill, [1984].
- [5] Çengel, Y.A. and A.B. Michael, "Thermodynamics An Engineering Approach.", McGraw Hill Companies, Inc., New York, 6th Edition .
- [6] C. Mborah, "On the Energy and Exergy Analysis of a 500 KW Steam Power Plant at Benso Oil Palm Plantation", Research journal of Environmental and Earth Sciences 2(4): 239-244, [2010].
- [7] Prof. Alpesh V. Mehta, "Thermodynamic Analysis of Gandhinagar thermal power station", International Journal of Advanced Engineering Technology, E-ISSN 0976-3945, December [2010].
- [8] "Energy efficiency in thermal utilities", Bureau of Energy Efficiency, Vol 2 pp 155-169 [2007].
- [9] Thyssen-krupp India ltd, "operation & maintenance manual design handbook", [2007].