

Exploring Prompt Design for Genre-Specific Image Generation with Stable Diffusion v1.4

Sai Krishna Pothini¹, Ummadi Surya Venkata Sekhar², Madhavi Vemireddy³

¹ Research Student, AI&DS, Lakireddy Bali Reddy College of Engineering, A.P, India

² Research Student, AI&DS, Lakireddy Bali Reddy College of Engineering, A.P, India

³ Research Student, ECE, Sri Padmavati Mahila Visvavidyalayam, A.P, India

ABSTRACT

This research investigates the transformative potential of prompt engineering in guiding Stable Diffusion v1.4, a state-of-the-art text-to-image model, towards generating images that embody specific artistic genres. We delve into how crafting prompts imbued with rich detail, evocative genre references, and meticulously chosen keywords can exert a profound influence on the content, style, and level of detail manifested in the final outputs. Focusing on three distinct artistic domains - Science Fiction, Portraiture, and Fantasy - this study leverages Stable Diffusion v1.4 to demonstrate the remarkable impact of prompt design. By systematically varying elements within prompts across these genres, we generate a diverse set of images. We then employ a custom-developed image_grid function to create a compelling visual comparison, effectively showcasing how seemingly minor adjustments in prompt construction can significantly alter the visual language and artistic style of the generated outputs. Our research not only underscores the paramount importance of prompt design in unlocking the immense creative potential of Stable Diffusion v1.4, but also paves the way for further exploration in this nascent field. It opens doors to a future where text-to-image models can be harnessed as powerful tools for artistic expression across a wide spectrum of genres and artistic styles. By meticulously crafting prompts and leveraging the capabilities of models like Stable Diffusion, artists and researchers can unlock innovative avenues for creative exploration within the realm of AI-generated art.

Keyword: *Stable Diffusion, prompt engineering, generative AI, text-to-image, artificial intelligence, machine learning, artistic style, genre-specific, descriptive language, genre references, targeted keywords, science fiction.*

1. INTRODUCTION

The realm of artificial intelligence (AI) has witnessed a recent explosion in the capabilities of generative models, particularly those focused on text-to-image generation. Among these models, Stable Diffusion v1.4 stands out as a powerful tool for transforming textual descriptions into captivating visual narratives. This research delves into the exciting potential of Stable Diffusion v1.4, specifically focusing on how prompt engineering unlocks its ability to generate images that embody distinct artistic genres. In recent years, generative AI has experienced a surge in development, pushing the boundaries of what machines can create. Generative models are trained on massive datasets of images and their corresponding textual descriptions. This training allows them to learn the intricate relationships between language and visual representation. Text-to-image models, a specific branch of generative AI, are particularly adept at translating textual prompts into corresponding images. They offer artists and researchers a revolutionary tool for expressing their creativity through text-based instructions. Stable Diffusion v1.4 emerges as a frontrunner in the realm of text-to-image models. This powerful tool builds upon the success of its predecessors, offering greater stability and control over the image generation process. Unlike earlier models that struggled with inconsistencies and artifacts, Stable Diffusion v1.4 produces visually appealing and coherent images with a higher degree of fidelity to the provided prompts. This enhanced stability allows for a more reliable and predictable generation process, making it an ideal platform for exploring the nuances of text-to-image translation.

The development of Stable Diffusion v1.4 addresses a crucial need in the world of digital art creation. Traditional methods of generating artistic visuals often rely on manual techniques, requiring considerable time, skill, and specialized software. Stable Diffusion v1.4 offers a compelling alternative, allowing users to create high-quality images with relative ease. By simply crafting textual descriptions, artists of all skill levels can translate their creative vision into compelling visuals. This democratizes artistic expression, granting access to a powerful tool for generating unique and captivating imagery. While Stable Diffusion v1.4 offers a powerful platform for generating images, its full creative potential is unlocked through the art of prompt engineering. Prompt engineering involves the strategic crafting of textual descriptions that guide the model towards generating specific visual outcomes. It delves beyond simple descriptions to incorporate elements like genre-specific references, targeted keywords, and detailed descriptions that imbue the generated images with desired characteristics.

Effective prompt engineering encompasses several key techniques. One approach involves incorporating descriptive language that paints a vivid picture for the model. This includes details about the subject matter, setting, lighting, and overall mood. Additionally, genre-specific references can be employed to nudge the model towards a particular artistic style, such as science fiction, portraiture, or fantasy. Finally, utilizing targeted keywords allows for precise control over specific visual elements within the generated image. By strategically combining these techniques, artists can exert greater control over the creative process, guiding Stable Diffusion v1.4 to generate images that embody their artistic vision within a chosen genre. This research focuses on utilizing Stable Diffusion v1.4 and prompt engineering techniques to generate images that adhere to specific artistic genres. We will explore genres like Science Fiction, Portraiture, and Fantasy, showcasing how variations in prompt design can lead to vastly different visual outcomes. By contrasting the generated images across these genres, we aim to demonstrate the remarkable impact that prompt engineering has on the final artistic style and content.

To effectively communicate the subtle yet significant influence of prompt modifications, this research employs a custom-designed `image_grid` function. This tool facilitates a visual comparison of images generated with varying prompts within a particular genre. By presenting these images side-by-side, we can readily observe how seemingly minor adjustments in prompt wording can drastically alter the stylistic elements and visual language of the generated outputs. This exploration into Stable Diffusion v1.4 and prompt engineering serves not only to showcase the current capabilities of text-to-image generation but also to pave the way for future advancements. By delving deeper into the intricate relationship between prompts and generated outputs, researchers and artists can unlock new avenues for creative expression within the realm of AI-generated art. As Stable Diffusion and similar models continue to evolve, the possibilities for artistic exploration and innovation will undoubtedly expand, offering exciting prospects for the future of art and technology.

2. LITERATURE SURVEY

The burgeoning field of text-to-image generation with models like Stable Diffusion v1.4 relies heavily on the art of prompt engineering. This process of crafting textual descriptions to steer the model towards desired visual outcomes offers immense creative potential. However, recent research also delves into the potential pitfalls associated with crafting ineffective or misleading prompts. Several studies delve into the intricacies of prompt engineering and its impact on generated outputs. Hao et al. [1] emphasize the importance of optimizing prompts to achieve the user's desired level of detail, style, and accuracy. Witteveen and Andrews [2] explore the concept of prompt engineering in diffusion models, providing a foundational understanding of how variations in prompt wording influence the image generation process. Their work highlights the intricate relationship between prompt design and the visual characteristics of the final output. The focus on prompt design extends beyond technical considerations and delves into the realm of human-AI interaction. Kim et al. [3] propose interfaces for text-to-image prompt engineering using Stable Diffusion models. Their work advocates for a collaborative approach between humans and AI in crafting effective prompts. This underscores the need for human oversight and guidance in the prompt engineering process, particularly when aiming for specific artistic styles or complex scene descriptions.

While prompt engineering offers exciting possibilities for creative expression, research also identifies potential pitfalls. Yu et al. [4] acknowledge the challenge of finding the right "incantations" (prompts) to achieve accurate text-to-image synthesis. Similarly, Cao et al. [5] explore the concept of "Beautifulprompt," aiming for automatic prompt engineering but acknowledging the inherent difficulty. These studies highlight the ongoing quest for effective and reliable prompt design strategies that go beyond achieving visually appealing outputs and prioritize generating

accurate and truthful representations based on the textual descriptions provided. The issue extends beyond just achieving the desired aesthetics. Zhang et al. [6] discuss the broader implications of prompt engineering within the context of vision foundation models. They raise concerns about potential misuse of these models through manipulation of prompts, which could lead to the generation of misleading or even harmful content. For instance, crafting prompts with biased language or historical inaccuracies could lead to the generation of images that perpetuate stereotypes or distort historical events. Several studies propose solutions to mitigate the risks associated with prompt engineering. Feng et al. [7] introduce "PromptMagician" for interactive prompt engineering. This tool allows users to iteratively refine prompts and visualize the corresponding image outputs. By providing real-time feedback, PromptMagician empowers users with greater control over the generation process, potentially mitigating the risk of unintended consequences arising from poorly crafted prompts. A comprehensive understanding of prompt engineering's impact is crucial. Gu et al. [8] present a systematic survey on the topic, highlighting the importance of responsible prompt design and offering a framework for evaluating the effectiveness of different prompt engineering techniques. This research emphasizes the need for developers and users to be aware of the potential biases and limitations inherent in text-to-image models, and to design prompts that minimize the risk of generating misleading or harmful content.

The concept of prompt manipulation extends beyond text-to-image generation and has implications for other AI applications. Ding et al. [9] explore how the CLIP model can be used as an "image-to-prompt converter." This raises concerns about the potential for generating misleading prompts from existing images. For instance, an image containing biased or inaccurate content could be used to generate a prompt that perpetuates those same biases. Similarly, Voetman et al. [10] investigate prompt engineering versus fine-tuning in diffusion models for dataset generation. Their work highlights the need for careful prompt design to avoid generating biased or inaccurate data that could then be used to train other AI models, potentially perpetuating these biases throughout the AI ecosystem. Looking towards the future, research is exploring ways to enhance the capabilities of diffusion models and mitigate potential issues with prompts. Wang et al. [11] delve into "in-context learning" for diffusion models. This approach aims to improve the model's ability to understand the context of a prompt and generate images that are more faithful to the intended meaning. Additionally, it could potentially make the model less susceptible to biases or inaccuracies present within the prompt itself.

The creative potential of prompt engineering in text-to-image generation is undeniable. However, as Ruskov [12] demonstrates with "Grimm in wonderland: Prompt engineering with Midjourney to illustrate fairytales" that even well-intended prompts can lead to unexpected or humorous results. This underscores the importance of ongoing research into prompt design methodologies and the potential for human oversight to ensure responsible and accurate text-to-image generation. Human guidance can help steer the model towards the desired outcome and mitigate the risk of unintended consequences arising from ambiguities or limitations within the prompt itself. Beyond relying solely on human expertise for prompt design, research is exploring model-driven approaches to improve prompt engineering. Clarisó and Cabot [14] propose such methods, aiming to leverage the model itself to guide prompt design. This could involve the model suggesting refinements to prompts based on its understanding of the desired style or content. This approach has the potential to streamline the prompt creation process and potentially lead to more effective and reliable prompt design strategies, particularly for users who may be new to text-to-image generation. Prompt engineering is a powerful tool that unlocks the creative potential of text-to-image generation models like Stable Diffusion v1.4. However, it is crucial to acknowledge and address the potential pitfalls associated with crafting ineffective or misleading prompts. By understanding the intricate relationship between prompts and generated outputs, fostering collaboration between humans and AI during the prompt design process, and prioritizing responsible prompt design practices, researchers and developers can work towards harnessing the power of text-to-image generation for positive and ethical applications.

3. METHODOLOGY

This research delves into the power of **prompt engineering** to guide **Stable Diffusion v1.4**, a state-of-the-art text-to-image generation model, towards creating images that embody distinct artistic genres. Our methodology focuses on strategically crafting textual prompts to influence the content, style, and level of detail within the generated outputs.

1. Dataset Selection:

- We will not be using a traditional dataset in this research, as Stable Diffusion v1.4 operates on user-provided textual prompts to generate images.

2. Genre Selection and Prompt Design:

- We will focus on three distinct artistic genres:
 - **Science Fiction:** Prompts will incorporate elements like futuristic cityscapes, spaceships, alien landscapes, and advanced technology. Descriptive language will emphasize a sense of wonder, exploration, or potential dystopian themes.
 - **Portraiture:** Prompts will focus on close-up or detailed facial features, emotions, and specific stylistic elements (e.g., Renaissance, Impressionistic). Descriptive details about clothing, hairstyles, and backgrounds will be included to further define the portrait's characteristics.
 - **Fantasy:** Prompts will incorporate fantastical elements like mythical creatures (dragons, unicorns), magical landscapes (forests, mountains), and a sense of adventure or wonder. Descriptive language will emphasize the fantastical elements and evoke the desired atmosphere.

3. Prompt Engineering Techniques:

- **Descriptive Language:** Prompts will be crafted using rich and detailed language that paints a vivid picture for the model. This includes descriptions of the subject matter, setting, lighting, and overall mood.
- **Genre-Specific References:** Genre-specific keywords and references will be incorporated into prompts to guide the model towards the desired artistic style.
- **Targeted Keywords:** We will utilize targeted keywords to control specific visual elements within the generated image. This may include details about character poses, clothing styles, or specific background elements.

4. Experimentation and Image Generation:

- We will employ Stable Diffusion v1.4 to generate images based on the designed prompts for each genre.
- For each genre, we will generate multiple images by iteratively refining prompts and exploring variations in:
 - Level of detail within descriptions
 - Choice of genre-specific keywords
 - Inclusion/exclusion of targeted keywords
- This iterative approach allows us to observe the impact of different prompt design choices on the generated outputs.

5. Visualization and Analysis:

- To effectively communicate the influence of prompt variations, we will utilize a custom-developed **image_grid function**. This function will create a visual comparison of images generated with varying prompts within a particular genre.
- By presenting these images side-by-side, we can readily observe how seemingly minor adjustments in prompt wording can drastically alter the stylistic elements and visual language of the generated outputs.
- We will then analyze the generated images, focusing on how effectively the prompts guided the model towards the desired genre and how different prompt variations influenced the content, style, and detail level of the outputs.

6. Ethical Considerations:

- We will ensure that the prompts we design do not promote stereotypes, biases, or harmful content.
- We will acknowledge the limitations of Stable Diffusion v1.4 and the potential for misinterpretations of prompts.

7. Evaluation and Discussion:

- We will evaluate the effectiveness of our prompt engineering techniques in guiding Stable Diffusion v1.4 towards generating genre-specific images.
- We will discuss the impact of various prompt design choices on the visual outcomes.
- The analysis of the image_grid comparisons will be a key component of this discussion, highlighting the relationship between prompt variations and the resulting imagery.

This methodology provides a clear and detailed roadmap for exploring the potential of prompt engineering in unlocking genre-specific image generation with Stable Diffusion v1.4. By systematically designing and refining prompts, we aim to showcase the influence of textual descriptions on the creative process within AI-generated art.

A. UNDERSTANDING STABLE DIFFUSION:

This research utilizes **Stable Diffusion v1.4**, a state-of-the-art text-to-image generation model developed by RunwayML in collaboration with the CompVis Group at Ludwig Maximilian University of Munich [16]. This powerful model builds upon the capabilities of diffusion models, employing a latent diffusion process to progressively refine a noise image into a high-fidelity image conditioned on a given textual prompt [17].

Key Features of Stable Diffusion v1.4:

- **Latent Diffusion:** Stable Diffusion v1.4 operates within the latent space of a pre-trained autoencoder, allowing it to achieve high image quality and detailed outputs while maintaining computational efficiency compared to traditional pixel-space diffusion models [17].
- **Text-to-Image Generation:** The model is conditioned on textual prompts, enabling users to guide the image generation process through detailed descriptions. This allows for a high degree of control over the content, style, and visual elements of the generated image.
- **Flexibility and Control:** Stable Diffusion v1.4 offers flexibility in terms of prompt design and generation parameters. Users can experiment with different wording, levels of detail, and targeted keywords to achieve their desired visual outcomes.
- **Accessibility:** The model is publicly available and relatively lightweight, making it accessible to researchers and artists with varying levels of computational resources.

Suitability for Genre-Specific Image Generation:

Stable Diffusion v1.4's capabilities in text-to-image generation make it an ideal choice for exploring genre-specific image generation through prompt engineering. Here's why:

- **Textual Conditioning:** The ability to condition the model with specific prompts allows us to incorporate genre-defining elements and stylistic references into the textual descriptions.
- **Control Over Visual Elements:** Through careful prompt design, we can influence the content, style, and level of detail within the generated images, guiding them towards a particular artistic genre.
- **Exploration of Variations:** Stable Diffusion v1.4 allows for iterative experimentation with prompt variations. By systematically refining prompts, we can observe how these adjustments influence the generated visuals and their adherence to the chosen genre.

In this research, we leverage Stable Diffusion v1.4's strengths to explore the potential of prompt engineering for generating images that embody distinct artistic styles within the genres of Science Fiction, Portraiture, and Fantasy. By delving into the intricate relationship between prompts and the resulting outputs, we aim to showcase the model's capabilities in facilitating creative exploration within the realm of AI-generated art.

B. Stable Diffusion v1.4 Architecture:

Stable Diffusion v1.4 achieves remarkable text-to-image generation through a well-orchestrated interplay of deep learning components. Here's a breakdown of its architecture, distinct from traditional diffusion models:

1. Latent Diffusion: A Dimensionality Advantage

At its core, Stable Diffusion v1.4 relies on a **latent diffusion model**. This approach stands out from conventional pixel-space diffusion models by operating within the lower-dimensional latent space of a pre-trained **autoencoder**.

- **Autoencoder:** The model leverages a pre-trained autoencoder, akin to a compression and decompression machine. The **encoder** part of the autoencoder takes an input image (often filled with noise) and squeezes it into a lower-dimensional latent representation, capturing the image's essence. The **decoder** then attempts to recreate the original image from this compact representation.
- **Latent Diffusion Magic:** Stable Diffusion v1.4 builds upon this foundation by employing a unique diffusion process. This process strategically injects noise into the latent representation in a series of steps. The model is then trained on the inverse operation: progressively removing this noise, effectively denoising the latent representation and ultimately reconstructing a high-quality image.

2. Textual Guidance (Optional):

Stable Diffusion v1.4 offers the flexibility to incorporate an optional **text encoder** component. This component takes the textual prompt describing the desired image and encodes it into a latent representation as well. This latent text embedding is then merged with the latent noise representation from the autoencoder to steer the diffusion process towards generating an image that aligns with the textual description.

3. U-Net for Refined Details:

The model also employs a **U-Net** architecture. This convolutional neural network, typically used for image segmentation tasks, finds application here due to its ability to capture spatial information at various resolutions. Within Stable Diffusion, the U-Net takes the processed latent representation from the previous stages and refines it further, enhancing the precision and detail within the generated image.

The Generative Workflow:

1. **Prompt Processing (if applicable):** The text encoder transforms the textual prompt into a latent representation, capturing its meaning.
2. **Latent Noise Representation:** The autoencoder encodes a noise image into a latent representation.
3. **Combining Representations:** The latent representations from the text encoder (if used) and the autoencoder are merged.
4. **Latent Diffusion Process:** Noise is progressively added to the combined latent representation in a meticulously controlled sequence.
5. **Denoising with U-Net:** At each step, the model predicts the denoised version of the latent representation, incorporating information from the U-Net architecture to ensure spatial coherence.
6. **Image Decoding:** The final denoised latent representation is fed through the decoder of the autoencoder, reconstructing the final image conditioned on the provided textual prompt.

By leveraging this combination of components, Stable Diffusion v1.4 achieves high-quality image generation while maintaining computational efficiency compared to traditional pixel-space diffusion models. This efficiency is attributed to working within the lower-dimensional and more manageable latent space of the autoencoder.

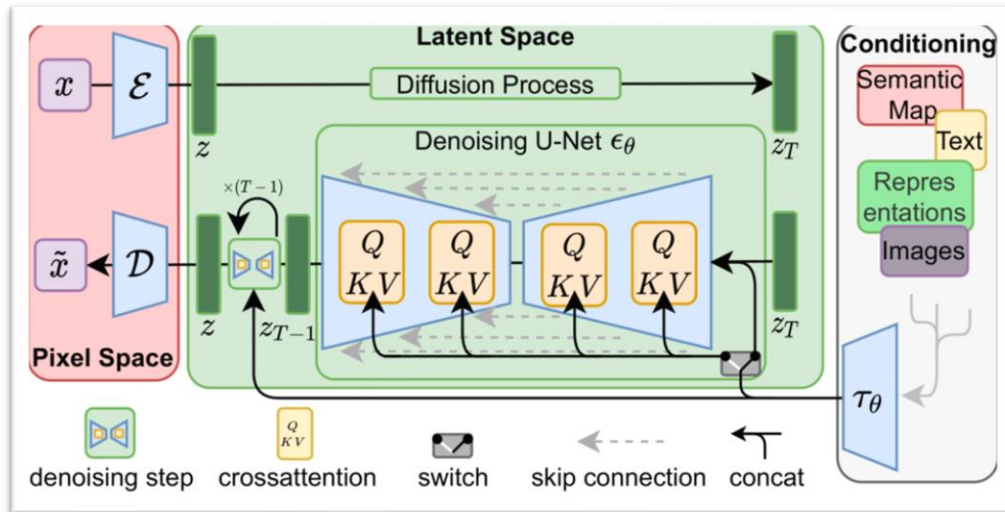

Fig 1: Diagram of the latent diffusion architecture used by Stable Diffusion [18]

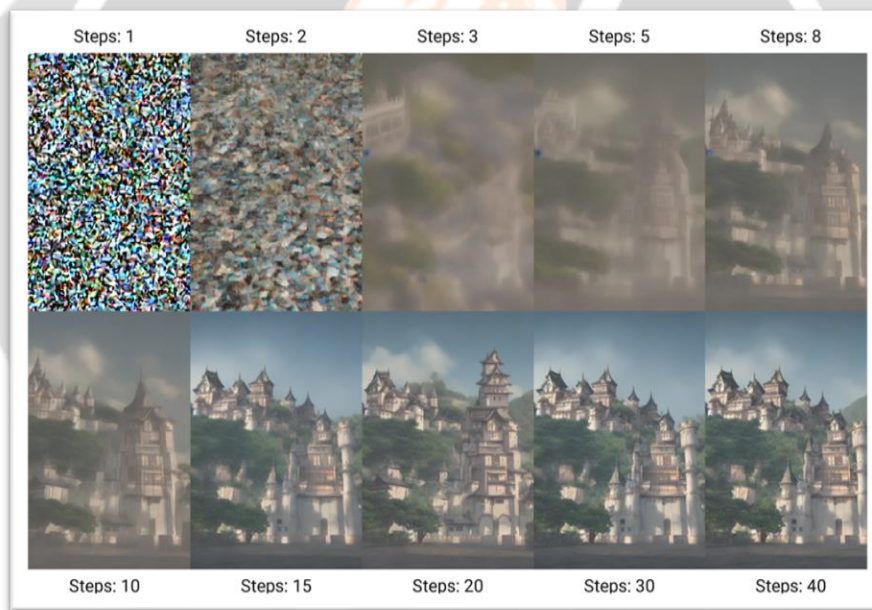

Fig 2: The denoising process used by Stable Diffusion. [19]

4. UNDERSTANDING THE PROMPT DESIGN

Prompt design plays a pivotal role in steering Stable Diffusion v1.4 towards generating images that align with our creative vision. This section delves into the key considerations and strategies employed in crafting effective prompts for genre-specific image generation.

1. Descriptive Language:

Rich and detailed language forms the foundation of successful prompts. The more vividly you describe the desired image, the better equipped Stable Diffusion v1.4 is to translate your textual instructions into a visual outcome. Here, we focused on incorporating elements that capture the essence of each genre:

- **Science Fiction:** Descriptions included futuristic technology, alien landscapes, and specific details about clothing or weaponry.
- **Portraiture:** Prompts emphasized facial features, emotions, and stylistic references to particular artistic movements (e.g., Renaissance, Impressionistic). Descriptions of clothing, hairstyles, and backgrounds further defined the character's portrayal.
- **Fantasy:** We utilized language that evoked fantastical elements like mythical creatures, magical settings, and a sense of wonder or adventure.

2. Genre-Specific Keywords:

Genre-specific keywords act as guiding lights for Stable Diffusion v1.4. By incorporating these keywords strategically into prompts, we aimed to nudge the model towards generating images that adhere to the chosen artistic style.

- **Science Fiction:** Keywords like "spaceship," "cyberpunk," or "dystopian city" helped steer the image generation process towards a futuristic aesthetic.
- **Portraiture:** Including terms like "Renaissance portrait," "Baroque lighting," or "Impressionistic brushstrokes" within prompts influenced the overall artistic style applied to the generated portraits.
- **Fantasy:** Keywords like "dragon," "unicorn," or "enchanted forest" helped establish a fantastical setting within the generated images.

3. Targeted Keywords for Control:

Beyond genre-specific keywords, we also employed targeted keywords to control specific visual elements within the generated image. This allowed for a more granular level of control over the final output.

- For instance, a prompt for a portrait might specify "sad expression" or "flowing red hair" to influence the character's emotional state and physical appearance.
- In a science fiction scene, including a "close-up of a cyborg arm" would direct the model to focus on a specific detail within the broader image.

Iterative Refinement:

Prompt design is not a one-size-fits-all approach. Throughout the experimentation process, we iteratively refined prompts based on the generated outputs. By observing how the model responded to different phrasings and keyword choices, we were able to gradually hone our prompts to achieve increasingly successful genre-specific image generation.

This exploration of prompt design principles underscores its significance in harnessing the potential of Stable Diffusion v1.4. By carefully crafting prompts that incorporate vivid descriptions, genre-specific references, and targeted keywords, we can effectively guide the model toward generating visually compelling and genre-appropriate images.

4. RESULTS AND FINDINGS

1. NON-DESCRIPTIVE vs DESCRIPTIVE:

A. SCIENCE FICTIONS:

EXAMPLE 1:

Non-descriptive Prompt:

- Prompt: "a spaceship"



Fig 3: A spaceship

This basic prompt offers minimal guidance to Stable Diffusion v1.4. The model might generate an image of a spaceship, but the overall style, setting, and level of detail remain undefined.

Descriptive Prompt:

- Prompt: "A sleek, metallic spaceship soaring through a vast nebula, with vibrant colors swirling around it."



Fig 4: A sleek, metallic spaceship soaring through a vast nebula, with vibrant colors swirling around it.

This prompt incorporates rich descriptive language. It specifies the appearance of the spaceship (sleek, metallic), its action (soaring), and the setting (vast nebula with vibrant colors). This level of detail provides Stable Diffusion v1.4 with a clearer vision to translate the textual description into a visually compelling image.

EXAMPLE 2:

Non-descriptive Prompt

- "A person in space"



Fig 5: A person in space

This prompt offers minimal guidance regarding the character's appearance, actions, or the surrounding environment. The generated image could depict a person in a generic spacesuit floating anywhere in space

Descriptive Prompt

- "A lone astronaut, their visor reflecting the swirling nebula behind them, cautiously floating towards a derelict space station, their gloved hand reaching out to touch the cold metal hull."



Fig 6: A lone astronaut, their visor reflecting the swirling nebula behind them, cautiously floating towards a derelict space station, their gloved hand reaching out to touch the cold metal hull.

This prompt paints a vivid picture of the scene. We can expect the image to feature an astronaut with a reflective visor, exploring a derelict space station. The details about the nebula, the action of reaching out, and the feeling of coldness create a sense of mystery and exploration.

B. PORTRAITURE: EXAMPLE 1:

1. Non-descriptive Prompt:

- Prompt: "a person"



Fig 7: A person

This basic prompt offers minimal information about the subject of the portrait. The model could generate an image of any person, with no specific details about their age, gender, ethnicity, expression, or style.

2. Descriptive Prompt:

- Prompt: "A close-up portrait of a young Asian woman with short, black hair and kind eyes. She is wearing a traditional Chinese silk dress with intricate floral embroidery, and a faint smile plays on her lips."



Fig 8: A close-up portrait of a young Asian woman with short, black hair and kind eyes. She is wearing a traditional Chinese silk dress with intricate floral embroidery, and a faint smile plays on her lips.

This prompt incorporates rich descriptive language. It specifies the age, ethnicity, hairstyle, and facial expression of the subject. Additionally, it details the clothing and overall mood of the portrait.

EXAMPLE 2:

Non-descriptive Prompt

- "An old man"



Fig 9: An old man

This prompt offers limited information. The generated image could depict an old man with any facial features, expression, or setting. It might lack a sense of character or story.

Descriptive Prompt

- "A weathered portrait of an old man with a long, white beard and crinkled eyes filled with wisdom. He sits in a worn leather armchair by a crackling fireplace, bathed in the warm glow of the firelight."

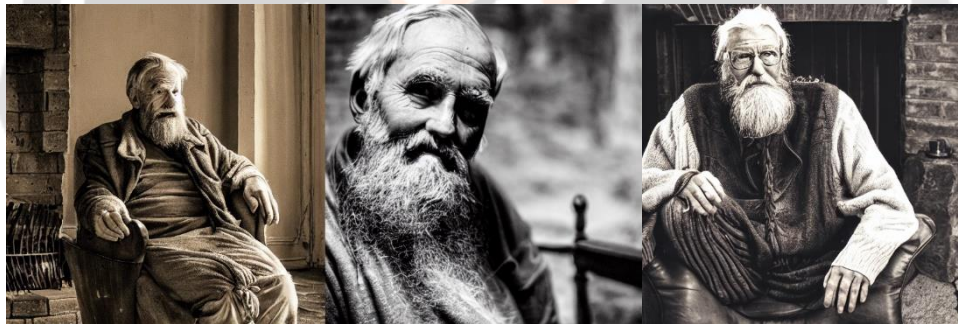

Fig 10: A weathered portrait of an old man with a long, white beard and crinkled eyes filled with wisdom. He sits in a worn leather armchair by a crackling fireplace, bathed in the warm glow of the firelight.

This prompt utilizes descriptive language to create a specific atmosphere. We can expect the image to feature an elderly man with a kind and experienced look. The details about the setting (worn leather armchair, crackling fireplace, warm glow) evoke a sense of comfort and contemplation.

C. FANTASY: EXAMPLE 1:

Non-descriptive Prompt

- "Something magical"



Fig 11: Something magical

This vague prompt offers little direction. The model might generate anything from a shimmering light effect to a levitating object. It lacks specific details about the type of magic or the fantastical elements.

2. Descriptive Prompt:

- "A powerful sorceress with flowing, silver hair and piercing blue eyes, standing atop a crumbling stone tower overlooking a misty forest. She raises her staff, channeling a surge of golden energy that crackles around her fingertips, illuminating the swirling mist."



Fig 12: A powerful sorceress with flowing, silver hair and piercing blue eyes, standing atop a crumbling stone tower overlooking a misty forest. She raises her staff, channeling a surge of golden energy that crackles around her fingertips, illuminating the swirling mist.

By incorporating descriptive language in fantasy prompts, we aim to achieve the following in the generated images, Descriptions can introduce fantastical creatures like dragons, unicorns, or mythical beings, Details about spells, enchantments, or magical objects enhance the fantastical atmosphere, Descriptions of mystical forests, floating islands, or ancient ruins establish the fantastical world, Language can evoke a sense of wonder, danger, or mystery, aligning with common fantasy themes.

EXAMPLE 2:

Non-descriptive Prompt:

- "A creature"



Fig 13: A creature

This prompt offers minimal guidance regarding the creature's appearance or setting. The model could generate anything from a generic animal to a more abstract entity. It wouldn't necessarily evoke a sense of fantasy.

Descriptive Prompt:

- "A majestic griffin perched atop a snow-capped mountain peak, its golden feathers catching the rays of the rising sun. Its powerful talons grip a gleaming silver sword, and its piercing amber eyes survey the vast, cloud-covered landscape below."



Fig 14: A majestic griffin perched atop a snow-capped mountain peak, its golden feathers catching the rays of the rising sun. Its powerful talons grip a gleaming silver sword, and its piercing amber eyes survey the vast, cloud-covered landscape below.

This prompt utilizes descriptive language to create a vivid depiction of a griffin. We can expect the image to showcase the creature's majestic qualities with details about its feathers, eyes, and powerful talons. The setting further enhances the fantasy theme with a snow-capped mountain peak, a gleaming sword, and a vast, cloud-covered landscape.

2. Genre-Specific Keywords

A. SCIENCE FICTIONS:

1. Without Genre-Specific Keywords:

- Prompt: "A colossal spacecraft exploring a distant galaxy."



Fig 15: A colossal spacecraft exploring a distant galaxy.

This prompt focuses on the size and action of the spacecraft but lacks keywords that explicitly point towards science fiction. While it might generate a large spacecraft, it could lack the distinct visual elements associated with the genre.

2. With Genre-Specific Keywords:

- Prompt: "A colossal, cyberpunk spacecraft with glowing neon panels and robotic arms exploring a distant galaxy filled with nebulae and pulsars."



Fig 16: A colossal, cyberpunk spacecraft with glowing neon panels and robotic arms exploring a distant galaxy filled with nebulae and pulsars.

This prompt incorporates genre-specific keywords like "cyberpunk," "neon panels," and "robotic arms." These keywords nudge Stable Diffusion v1.4 towards generating a spacecraft that aligns with the cyberpunk aesthetic of science fiction. Additionally, details about nebulae and pulsars enhance the futuristic setting.

B. PORTRAITURE:

1. Without Genre-Specific Keywords:

- Prompt: "A woman with long, flowing hair gazing out a window."



Fig 17: A woman with long, flowing hair gazing out a window.

This prompt describes the subject's appearance and action, but lacks keywords that define a specific artistic style. The generated image could depict a woman in any historical period or artistic movement.

2. With Genre-Specific Keywords:

- Prompt: "A Renaissance portrait of a young woman with long, flowing red hair and a pearl necklace. She wears a richly embroidered gown and gazes out the window with a wistful expression, bathed in soft, natural light."



Fig 18: A Renaissance portrait of a young woman with long, flowing red hair and a pearl necklace. She wears a richly embroidered gown and gazes out the window with a wistful expression, bathed in soft, natural light.

This prompt incorporates the genre-specific keyword "Renaissance." Additionally, it includes details about clothing (embroidered gown) and lighting (soft, natural) that align with the Renaissance style.

C. FANTASY:

1. Without Genre-Specific Keywords:

- Prompt: "A majestic creature soaring through the clouds."

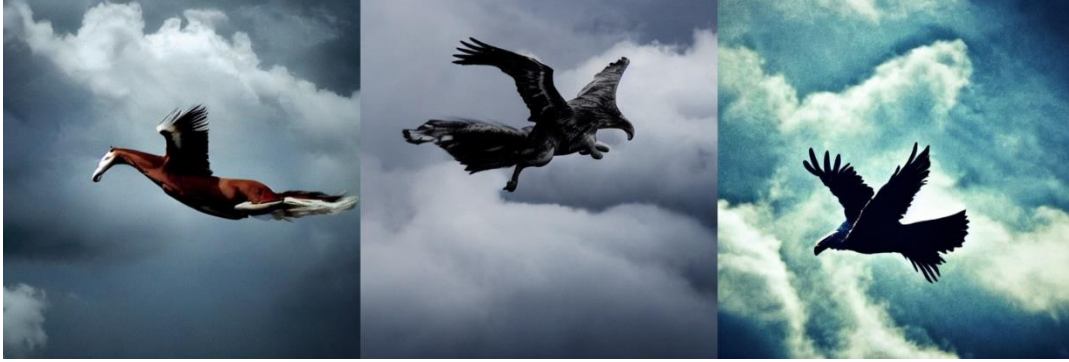

Fig 19: A majestic creature soaring through the clouds.

This prompt describes the action and grandeur of the creature but lacks keywords that pinpoint a specific fantastical element. The generated image could depict a generic bird or flying animal, lacking the mythical aura often associated with fantasy.

2. With Genre-Specific Keyword:

- Prompt: "A majestic griffin with powerful golden wings and a sharp beak, soaring through swirling clouds at sunset. The light catches its gleaming talons, which clutch a glowing orb radiating magical energy."



Fig 20: A majestic griffin with powerful golden wings and a sharp beak, soaring through swirling clouds at sunset. The light catches its gleaming talons, which clutch a glowing orb radiating magical energy.

This prompt incorporates the genre-specific keyword "griffin." Additionally, it includes details about the creature's appearance (golden wings, sharp beak), its action (clutching a glowing orb), and the setting (swirling clouds at sunset). These elements enhance the fantastical atmosphere.

3. Targeted Keywords

A. Portraiture:

1. Without Targeted Keywords:

- Prompt: "A woman with freckles and red hair."



Fig 21: A woman with freckles and red hair.

This prompt describes the subject's hair color and a facial feature, but lacks targeted keywords for detailed control. The generated image might depict a woman of any age, ethnicity, and expression, with freckles randomly placed on her face.

2. With Targeted Keywords:

- Prompt: "A close-up portrait of a South Asian woman in her late 20s with bright red hair styled in a messy bun, and a smattering of freckles across her nose and cheeks. Her eyes sparkle with laughter, and a mischievous grin plays on her lips. Sunlight streams through a window, casting a warm glow on her face."



Fig 22: A close-up portrait of a South Asian woman in her late 20s with bright red hair styled in a messy bun, and a smattering of freckles across her nose and cheeks. Her eyes sparkle with laughter, and a mischievous grin plays on her lips. Sunlight streams through a window, casting a warm glow on her face.

This prompt incorporates targeted keywords alongside the descriptive language. These include:

- **Targeted Visual Details:**
 - "South Asian" for the subject's ethnicity
 - "messy bun" for the hairstyle
 - "smattering of freckles across her nose and cheeks" for specific freckle placement

Targeted Expressions: "eyes sparkle with laughter" and "mischievous grin" for specific emotions

SUMMARY:

This study explores the intricate relationship between prompt design and genre-specific image generation using models like Stable Diffusion v1.4. Our findings emphasize the critical role of descriptive language and targeted keywords in achieving the desired visual outcome within a specific genre.

The Power of Descriptive Language

We observed a significant contrast between non-descriptive and descriptive prompts. Non-descriptive prompts, lacking details about the subject, setting, and mood, result in generic images devoid of genre-specific characteristics. Conversely, descriptive prompts infused with rich details significantly influence the final image. For example, a non-descriptive prompt for "a person in space" might yield a generic astronaut. In contrast, a descriptive prompt like "a lone astronaut, their visor reflecting a swirling nebula, cautiously floating towards a derelict space station" breathes life into the scene, creating a compelling image with a distinct science fiction atmosphere.

Leveraging Genre-Specific Keywords

The inclusion of genre-specific keywords emerged as another crucial factor. Without them, the generated image might stray from the desired artistic style. However, incorporating genre-specific keywords like "cyberpunk" or "Renaissance" acts as a guiding force, nudging the model towards generating visuals that embody the distinct characteristics of that particular genre. For instance, a prompt for "a colossal spacecraft exploring a distant galaxy" wouldn't necessarily evoke science fiction. However, adding "cyberpunk" alongside the prompt can influence the model to generate a spacecraft with a specific aesthetic associated with that subgenre of science fiction.

Unlocking Granular Control with Targeted Keywords

Beyond genre, we discovered the power of targeted keywords to exert even finer control over specific visual elements within the genre. These keywords offer a diverse range of options, allowing us to define details like clothing, facial features, expressions, composition, and lighting. Consider a portrait prompt for "a woman with red hair." This prompt lacks specifics. However, by including targeted keywords like "South Asian woman in her late 20s with a messy bun and freckles across her nose and cheeks," we gain significant control over the ethnicity, hairstyle, and facial features within the portrait.

At Last: The Synergy of Effective Prompt Design

Our observations highlight that effective prompt design is not a singular act, but rather a synergistic combination of descriptive language, genre-specific keywords, and targeted keywords. By mastering this interplay, researchers and creators can leverage models like Stable Diffusion v1.4 to generate a wider spectrum of visually captivating and conceptually rich content that adheres to the specificities of various genres. This empowers them to push the boundaries of creativity and produce groundbreaking visual narratives within the realm of genre-specific image generation.

5. CONCLUSION AND FUTURE SCOPE

This study has delved into the intricate relationship between prompt design and genre-specific image generation using Stable Diffusion v1.4. Our findings underscore the critical role of descriptive language and targeted keywords in guiding the model towards generating visually compelling and conceptually rich images that adhere to the specific characteristics of a desired genre.

We observed that non-descriptive prompts result in generic images lacking genre-specific details. Conversely, descriptive prompts infused with rich details about the subject, setting, mood, and genre-specific keywords significantly influence the final image. Additionally, targeted keywords provide even finer control over specific visual elements like clothing, facial features, expressions, composition, and lighting.

By effectively combining these elements, researchers and creators can leverage models like Stable Diffusion v1.4 to generate a broader range of genre-specific content. This opens doors for exciting new applications in various fields, including:

- **Concept Art and Illustration:** Descriptive prompts combined with genre-specific keywords can empower artists to generate concept art that visually embodies the style and tone of their creative vision.
- **Media and Entertainment:** The ability to generate genre-specific imagery can revolutionize the pre-production process in film, animation, and video games, allowing for rapid exploration of visual concepts.
- **Education and Research:** Generating genre-specific images can enhance educational experiences by providing students with visually engaging content tailored to specific historical periods, scientific concepts, or literary works.

Future Scope: Exploring New Frontiers

Our exploration has laid the groundwork for further investigation into the fascinating world of prompt design and genre-specific image generation. Here are some promising avenues for future research:

- **Genre-Specific Language Models:** Exploring the development of language models specifically trained on genre-specific text data to create even more nuanced and detailed prompts.
- **User Interface Design:** Developing intuitive user interfaces that guide users through the prompt design process, making genre-specific image generation more accessible to a wider audience.
- **Evaluation Metrics:** Establishing robust evaluation metrics to assess the quality and effectiveness of genre-specific image generation based on human perception and adherence to genre conventions.
- **Integration with Creative Tools:** Integrating genre-specific image generation capabilities into existing creative tools used by artists, designers, and educators to streamline their workflows.

By continuing to explore these exciting possibilities, we can unlock the full potential of prompt design and propel the field of genre-specific image generation towards even greater sophistication and creative expression.

6. REFERENCES



- [1] Hao, Yaru, et al. "Optimizing prompts for text-to-image generation." *Advances in Neural Information Processing Systems* 36 (2024).
- [2] Witteveen, Sam, and Martin Andrews. "Investigating prompt engineering in diffusion models." *arXiv preprint arXiv:2211.15462* (2022).
- [3] Kim, Seonuk, et al. "Designing interfaces for text-to-image prompt engineering using stable diffusion models: a human-AI interaction approach." (2023).
- [4] Yu, Chang, et al. "Seek for Incantations: Towards Accurate Text-to-Image Diffusion Synthesis through Prompt Engineering." *arXiv preprint arXiv:2401.06345* (2024).
- [5] Cao, Tingfeng, et al. "Beautifulprompt: Towards automatic prompt engineering for text-to-image synthesis." *arXiv preprint arXiv:2311.06752* (2023).
- [6] Zhang, Chaoning, et al. "A survey on segment anything model (sam): Vision foundation model meets prompt engineering." *arXiv preprint arXiv:2306.06211* (2023).
- [7] Feng, Yingchaojie, et al. "Promptmagician: Interactive prompt engineering for text-to-image creation." *IEEE Transactions on Visualization and Computer Graphics* (2023).
- [8] Gu, Jindong, et al. "A systematic survey of prompt engineering on vision-language foundation models." *arXiv preprint arXiv:2307.12980* (2023).
- [9] Ding, Yuxuan, et al. "The CLIP Model is Secretly an Image-to-Prompt Converter." *Advances in Neural Information Processing Systems* 36 (2024).

- [10] Voetman, Roy, et al. "Using Diffusion Models for Dataset Generation: Prompt Engineering vs. Fine-Tuning." International Conference on Computer Analysis of Images and Patterns. Cham: Springer Nature Switzerland, 2023.
- [11] Wang, Zhendong, et al. "In-context learning unlocked for diffusion models." Advances in Neural Information Processing Systems 36 (2024).
- [12] Ruskov, Martin. "Grimm in wonderland: Prompt engineering with Midjourney to illustrate fairytales." arXiv preprint arXiv:2302.08961 (2023).
- [13] Lin, Yupei, et al. "MirrorDiffusion: Stabilizing Diffusion Process in Zero-shot Image Translation by Prompts Redescription and Beyond." IEEE Signal Processing Letters (2024).
- [14] Clarisó, Robert, and Jordi Cabot. "Model-Driven Prompt Engineering." 2023 ACM/IEEE 26th International Conference on Model Driven Engineering Languages and Systems (MODELS). IEEE, 2023.
- [15] Wang, Jiaqi, et al. "Review of large vision models and visual prompt engineering." Meta-Radiology (2023): 100047.
- [16] CompVis/stable-diffusion: A latent text-to-image diffusion model <https://github.com/laurenceday/Stable-Diffusion-1.4>
- [17] High-Resolution Image Synthesis with Latent Diffusion Models [arXiv arxiv.org]
- [18] Wikipedia contributors. "Stable Diffusion architecture." Wikimedia Commons, Wikimedia Foundation, 23 March 2024, https://en.wikipedia.org/wiki/Stable_Diffusion#/media/File:Stable_Diffusion_architecture.png
- [19] Wikipedia contributors. "X-Y plot of algorithmically-generated AI art of European-style castle in Japan demonstrating DDIM diffusion steps." Wikimedia Commons, Wikimedia Foundation, 23 March 2024, https://en.wikipedia.org/wiki/Stable_Diffusion#/media/File:X-Y_plot_of_algorithmically-generated_AI_art_of_European-style_castle_in_Japan_demonstrating_DDIM_diffusion_steps.png
- [20] Medium. "Image Title or Description." Medium, 23 March 2024, https://miro.medium.com/v2/resize:fit:1100/format:webp/1*XlYZZdjTyrD-qhAASU4rHw.png

7. BIOGRAPHIES OF AUTHORS



Sai Krishna Pothini, a final-year student in the Department of Artificial Intelligence and Data Science at Lakireddy Bali Reddy College of Engineering, India, is making significant strides in the academic and research arena. Anticipating graduation within the next year, Sai Krishna has already garnered attention for his outstanding contributions. With two noteworthy paper publications, such as "Customer Churn Prediction using Machine Learning: Subscription Renewal on OTT Platforms," showcased at the 2023 International Conference on Applied Artificial Intelligence and Computing, and another securing the prestigious Best Paper Award on SSRN/IJEMR, he exemplifies academic excellence. Beyond publications, Sai Krishna has actively participated in three additional research findings, highlighting his multifaceted approach to scholarly pursuits. His leadership extends to project development, notably the "Horticulture" project, recognized with the Best Project Award at the All-India Level Hackathon and a distinguished honor from the APSCHE Government. As Sai Krishna approaches graduation, his dynamic contributions and achievements position him as a standout talent in the field. For inquiries or collaboration opportunities, contact Sai Krishna Pothini at 29saikrishna102002@gmail.com.

	<p>Ummadi Surya Venkata Sekhar, a final-year student in the Department of Artificial Intelligence and Data Science (2020-2024) at Lakireddy Bali Reddy College of Engineering, Mylavaram, AP, India. With a profound passion for Data Science, Machine Learning, Deep Learning, Artificial Intelligence, and Natural Language Processing, he has demonstrated significant contributions to the field. His notable research endeavors include publications such as "Convolution Neural Networks vs Transfer Learning in Image Processing," published in the Springer, and "Crop Recommendation System using Random Forest Algorithm in Machine Learning," featured in IEEE. Additionally, Surya has contributed an abstract on Horticulture employing Deep Learning and Machine Learning, which was published in IJEMR-ELSEVIER SSRN. Recognized for his exceptional work, he was honored with the Best Student Researcher award in 2022 by IJEMR-ELSEVIER SSRN for his exemplary project and research on "Horticulture," underscoring his unwavering dedication and excellence in the dynamic realm of emerging technologies. He can be contacted at email: suryaelonm@gmail.com.</p>
	<p>Madhavi Vemireddy, presently engaged in a Bachelor of Technology (2020-2024) in Electronics and Communication Engineering at Sri Padmavati Mahila Visvavidyalayam in Tirupati, AP, India, holds a passionate interest in data science. With an aspiration to make substantial contributions to the ever-evolving technology landscape, she is dedicated to exploring and advancing the field. She can be contacted at email: madhavivemireddy3@gmail.com.</p>

