

Improving The Segmentation of Digital Images by Using a Modified Image Segmentation Techniques

Priya Ranjan Kumar, Dr. Dinesh Kumar Sahu

SRK University, Bhopal M.P., India

ABSTRACT

image processing is any kind of signal processing for which the input is an image, such as photographs or frames of video; the output of image processing can be an image. Image processing plays an important role in computer vision. The process of image segmentation provides the partition of image into different segments according to their feature attribute. Region based segmentation is a type similarity based segmentation. Another type of segmentation is called thresholding based segmentation. In thresholding based segmentation method some thresholding techniques are used. Thresholding techniques are classified into two major categories as, Global and Local. In global thresholding, pixel values are categorized in two classes, one class belong to object and another class belong to background. We use one threshold value in global thresholding for whole image that belongs to single level thresholding and if threshold value used in segmentation is more than one, technique is called multilevel thresholding. Local thresholding belongs to multilevel thresholding method. In this paper a comparative analysis of global thresholding and local thresholding methods is made according to time taken for image segmentation. Experimental results provide a conclusion that Global thresholding takes less time than local thresholding.

Keywords: Image Segmentation, Thresholding, Local Thresholding, Global Thresholding.

INTRODUCTION

An image is further segmented to observe each of these objects residing in the region to extract some vital information of high level. The output of image segmentation technique is a group of segments that totally able to cover the entire image, or a set of contours lines retrieved from the image parts. An image is a systematic arrangement of regions and shapes or objects and not just a group of pixels. Extracting bits of information from a source image is considered as image processing which is one of the prerequisite steps in pattern identification systems. Each part of the image is a group of set of pixels. Image segmentation is term which constitutes classification of all the pixels into different clusters in an image that exhibit similar patterns. This is a technique of dividing an image object into its component's objects in the image parts i.e. set of pixels/regions such that pixels in a region are equivalent while considering some homogeneity criteria to be compared such as color, texture or intensity so as to identify boundaries in a particular region of an image [12].

An image is further segmented to observe each of these objects residing in the region to extract some vital information of high level. The output of image segmentation technique is a group of segments that totally able to cover the entire image, or a set of contours lines retrieved from the image parts. Adjacent parts are significantly dissimilar to the characteristic which are equivalent. Segmentation is required in a wide range of algorithms. Different software libraries need different types of objects. The mostly used images are light intensity and range image, computerized tomography, magnetic resonance images. Image segmentation is dependent on the type of an image; hence there is no one generalized scheme that is most suitable for all kinds of images [13].

Normally, regions are divided into two types on the basis of their present color in the image, i.e. gray scale image and colorful one. Therefore, image segmentation for non-gray scale images is from the bottom different from gray scale images, e.g., For content based image retrieval techniques. Segmentation can be either local or global per technique used. In Local segmentation, small windows are generated on a whole image and segmenting sub image. Global segmentation constitutes segmenting whole image. Global segmentation is used on large no of pixel. Local segmentation is used to deal with lesser no of pixel when compared to global segmentation [14]. Segmentation methods can be classified into seven groups. (1) Histogram thresholding, (2) Clustering (Soft and Hard), (3) Region growing, region splitting and merging, (4) Edge-based, (5) Physical model based, (6) Fuzzy approaches, and (7) Neural network and GA (Genetic algorithm) based approaches [7].

The rest of paper discuss as in section 2 discuss the JPEG file format. In section 3 discuss the ProblemFormulation. In section 4 discuss proposed Work. In section 5 discuss the experimental result and analysis. finally discuss conclusion & future work in section 5.

2. JPEG FILE FORMAT

Images saved in loss compression formats such as JPEG are not meant for high-resolution imaging, nor, was the format created to be used for image preservation. The use of the JPEG image file format as a primary imaging format such as in DSLR cameras was not a goal of the Joint Photographers Expert Group (Released 1992). The format was devised to limit the file size, and to allow for quick access and display of an image on the internet. The format was adopted by the camera manufacturers to compensate for the small size of the original memory cards (8-32 MB) used to store images onboard the camera. JPEG uses two major compression technologies (a) conversion of the RGB color space into YCC (50-75% color compression) and (2) discrete cosign transform (DCT) that creates blocks of varying spatial compression depending upon (i) image complexity and (ii) quality level selected by user. For a given quality setting (1-12), different images will yield widely differing file sizes and image appearances. An image with significant texture and fine detail will produce a relatively large JPEG file, no matter the quality setting, while an image consisting largely of blue sky and clouds will produce a much small file size. Lossy compression is an irreversible way of reducing the size of data by approximating it from the original bitmap image. Once bitmapped image information has been lost it cannot be recovered. The process is irreversible and iterative. Saving the same image as a JPEG over and over recompresses the image. If a JPEG image is to be manipulated and resaved, especially saved several times during the manipulation process, it should first be converted into a TIFF file [9].

The image will be the same, the original compression artifacts will still be there, but when it is resaved eventually as a JPEG, less overall compression will be applied to the image. Trying to improve the appearance of a JPEG image by re-compressing at a higher quality setting achieves very little except an increase in file-size. Once data is compressed, it is gone, no matter what the “seeming enhancements” software will allow, such as a higher quality level. For a given quality setting (1-12) when saving, different images will yield widely differing file sizes and image appearances. An image with lots of texture and fine detail will produce a large JPEG file, while one consisting only of blue sky will be very small. The JPEG compression process uses the DCT (Discrete Cosign Transfer) coding algorithm. The degree of possible compression is estimated for each step, some are cumulative some steps are one-time-only compressions, or, full data losses [16].

3. ROLE AND IMPORTANCE OF IMAGE SEGMENTATION

Segmentation is most important to analyze and interpret an image automatically. It bridges the gap between low level image processing and high level image processing. Mostly, some type of Segmentation technique is used in the applications which involve detection, recognition and measurement of objects in images. The role of the segmentation is very crucial in tasks which require image analysis. Because the success or failure of the task depends directly on segmentation result. However, It is very difficult to achieve a reliable and accurate segmentation of an image without using the segmentation technique. Histogram Thresholding does not need prior information of the image. For a wide class of images satisfying the requirement, segmentation works very well with low computation complexity. Feature Space Clustering straightforward [6] for classification and easy for implementation. Region-Based Approaches Work best when the region homogeneity criterion is easy to define. They are also more noise-immune than edge detection approach. Edge Detection Approaches Edge detecting techniques the way in which human perceives objects and works well for images having good contrast between regions. Fuzzy Approaches Fuzzy membership function can be used to represent the degree of some properties or linguistic phrase, and fuzzy IF-THEN rules can be used to perform approximate inference. Neural Network Approaches No need to write complicated programs. It can fully utilize the parallel nature of neural networks.

4. PROPOSED ALGORITHM

Image segmentation is process in which process image is segmented in predefined parts. The process of image segmentation uses the concept of thresholding. The thresholding technique defines in terms of local thresholding and global thresholding. Apart from the straight concept of thresholding various types of thresholding algorithm is available now a days. Here we have compared two threshold based image segmentation technique.

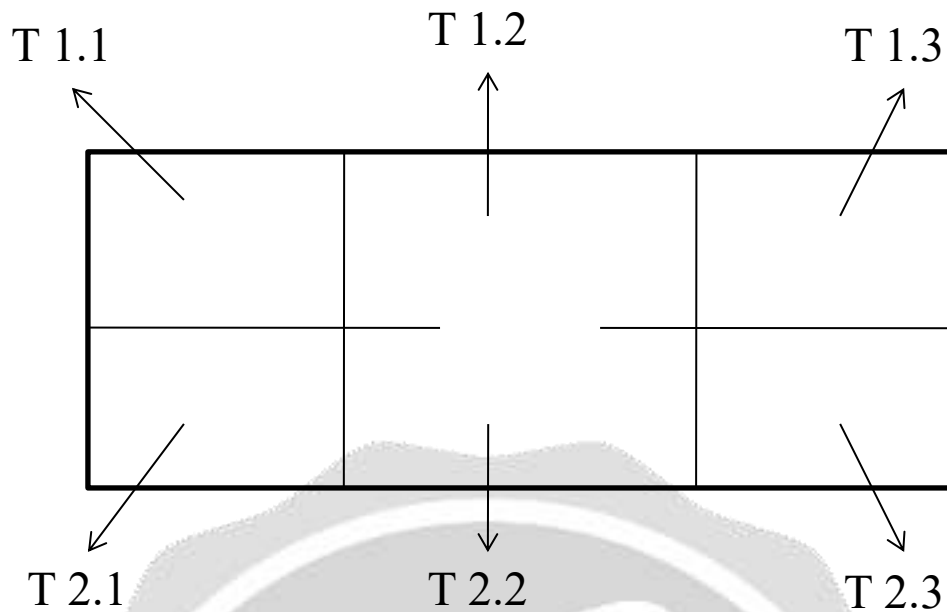

Figure 1: shows that image partition technique

Thresholding is the process of converting a gray scale image to a bi-level image using an optimum threshold value T . It is a process of partitioning an image into object pixels and background pixels. An individual pixel is made an object pixel if the pixel value is greater than a certain threshold value and a background pixel otherwise [8]. There are two types of thresholding algorithms:

- Global Thresholding Method
- Local or Adaptive Thresholding Method

Global Thresholding Methods uses a single global value of threshold to partition an image into distinct regions where as a Local Method uses different local value of threshold for different area [9].

Thresholding is an important technique in image segmentation applications. Its main aim is to classify the pixels of an image into two classes that is, object and the background. The basic idea is to select an optimal threshold value [7] for separating objects from the background. The gray level histogram of an image is usually considered as efficient tools for development of image thresholding algorithms [15]. Many threshold methods have been proposed to binarize the image. Otsu method is global thresholding selection method, which is widely used due to its simple and effective process. Traditional thresholding techniques based on histogram of the image suffered two major limitations:

- Unable to consider contextual information for selecting optimum threshold.
- Inefficient for multilevel thresholding as computationally demanding and complicated to implement [10]

A simple algorithm:

1. Initial estimate of T (the average intensity of the image is a good initial choice for T)
2. Initially put the value of ΔT that will be minimum like 0.1. parameter ΔT is used to control the number of iterations in situations where speed is an important issue.
3. Segmentation using T :
 - G1, pixels brighter than T ;
 - G2, pixels darker than (or equal to) T .
4. Computation of the average intensities m_1 and m_2 of G1 and G2.
5. New threshold value:

$$T_{\text{new}} = (m_1 + m_2)/2$$

6. If $|T - T_{new}| > \Delta T$, Repeat steps 2 through 4 until the distinction in T in progressive iteration is smaller than a predetermined parameter ΔT .

5. EXPERIMENTAL RESULT ANALYSIS

For the performance evaluation procedure some images, namely Barbara, Brain and Camera Man, have been taken. These images are given as input to the global thresholding algorithm and local thresholding algorithm. The results are compared on the basis of execution time taken by both algorithms.

Name Of Image	Name of Method	Execution Time
Barbara	Local	5.690
	Global	0.532
Brain	Local	0.640
	Global	0.431
Camera Man	Local	0.769
	Global	0.632

Table 1: Comparative performance evaluation for the local and global image segmentation techniques with the various images.

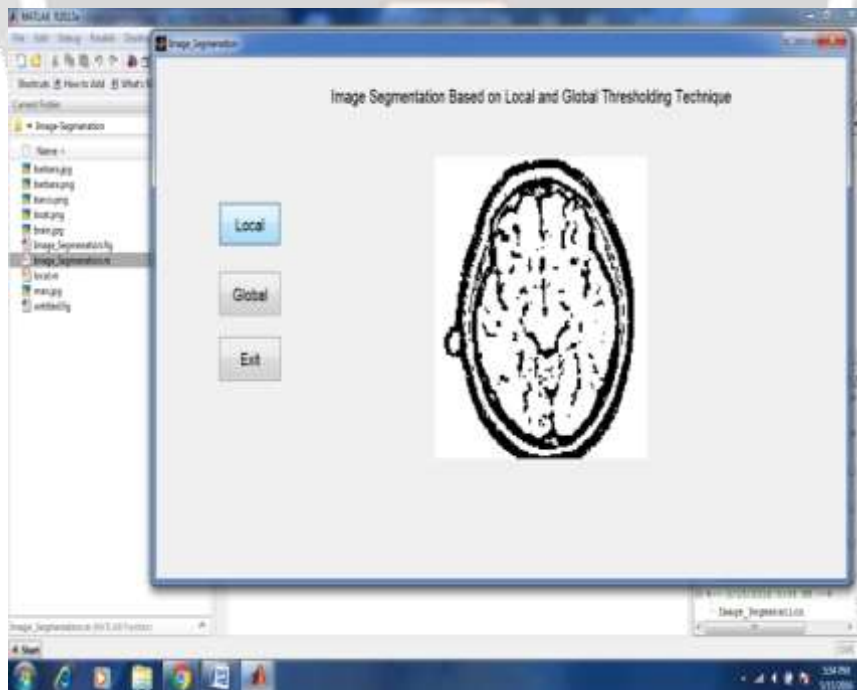

Figure 2: Describe the experimental window for local image threshold segmentation method with original Brain image .

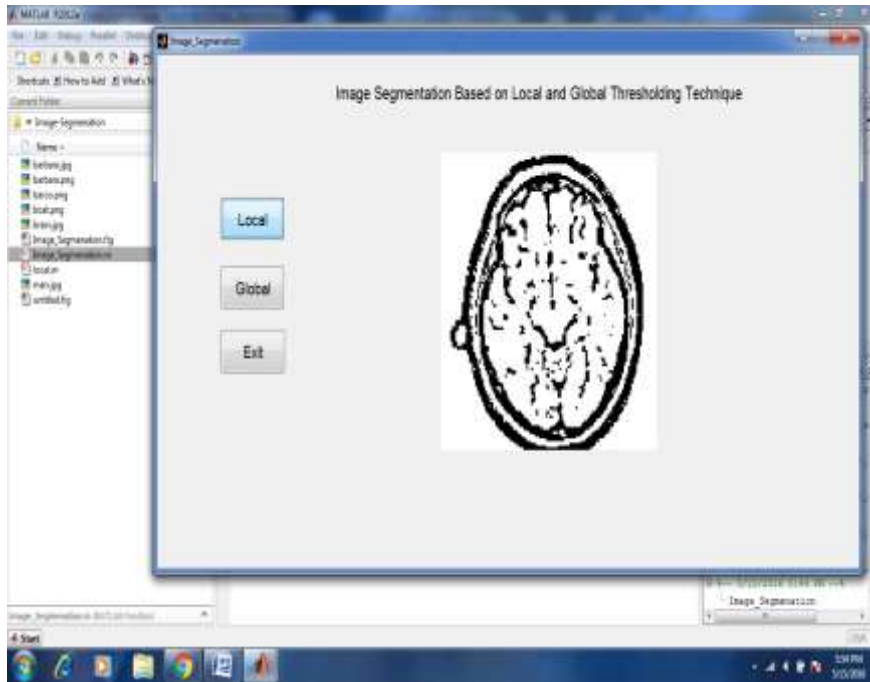

Figure 3: Describe the experimental window for global image segmentation method with original Brain image e.

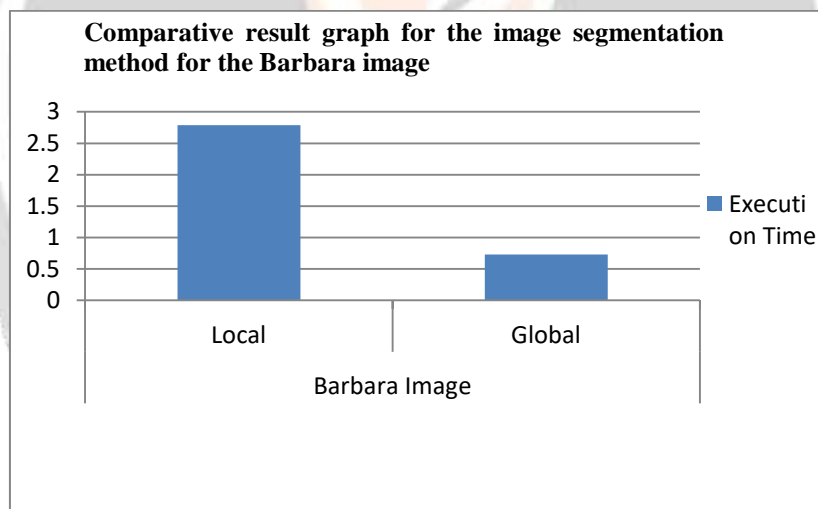

Figure 4: Comparative result graph for the Barbara image.

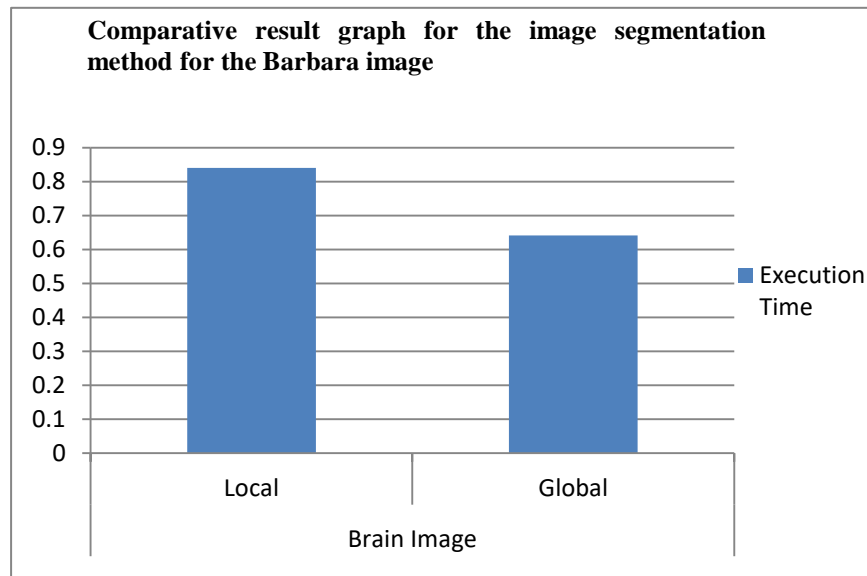

Figure 5: Comparative result graph for the Brain image.

6.CONCLUSION AND FUTURE WORK

image processing is any kind of signal processing for which the input is an image, such as photographs or frames of video; the output of image processing can be an image. Image segmentation plays a vital role in computer vision. The process of image segmentation provides the partition of image into different segment according to their feature attribute. Thresholding is the simplest method of image segmentation. For the validation of global and local image segmentation algorithm implement done in MATLAB software and used reputed standard image dataset such as cameraman, Barbara and boat image. For the evaluation of performance of algorithm, elapsed time or execution time of both algorithms is used. Our experimental result shows that the global thresholding algorithm is very efficient instead of local image segmentation. In future, Image segmentation methods can be applied to video formats in order to process video files. Also, there are many more methods fuzzy cluster means or tri class method, results can be analyzed for them.

REFERENCES

- [1] Andy Tsai, Anthony Yezzi, Jr. and Alan S. Willsky, "Curve Evolution Implementation of the Mumford–Shah Functional for Image Segmentation, Denoising, Interpolation, and Magnification," IEEE Transactions On Image Processing, Vol.10, No.8, AUGUST 2001 pp. 1169-1186.
- [2] R. C. Gonzalez and R. E. Woods, Digital Image Processing (Prentice Hall, 2018).
- [3] J. K. Aggarwal and R. O. Duda, "Special issue on digital filtering and image processing," IEEE Transaction Circuits System, Vol. CAS-2, 1975 pp. 161-304.
- [4] Anil K.Jain, "Fundamental of digital image processing".
- [5] Mohamed A. El-Sayed, Tarek Abd-El Hafeez, "New Edge Detection Technique based on the Shannon Entropy in Gray Level Images," International Journal on Computer Science and Engineering (IJCSSE) Vol. 3 No. 6, June 2011, pp. 2224- 2232.
- [6] Xiao-Feng Wang, De-ShuangHuang, HuanXu, "An efficient local Chan–Vese model for image segmentation," Pattern Recognition 43, 2018, pp. 603 – 618.
- [7] S.K Somasundaram, P.Alli, "A Review on Recent Research and Implementation Methodologies on Medical Image Segmentation," Journal of Computer Science, Vol. 8, No.1, 2017, pp. 170-174.

- [8] Baidya Nath Saha, Nilanjan Ray, Russell Greiner, Albert Murtha, Hong Zhang, "Quick Detection of Brain Tumors and Edemas: A Bounding Box Method Using Symmetry," Computerized Medical Imaging and Graphics, ISSN 08956111. 2016, pp. 95-107.
- [9] S. S. Varshney, N. Rajpal, R. Purwar, "Comparative Study of Image Segmentation Techniques and Object Matching using Segmentation," Proceeding of International Conference on Methods and Models in Computer Science, 2009, pp. 1-6.
- [10] S. Jayaraman, S. Esakkirajan, T. Veerakumar, "Digital Image Processing," Tata McGraw Hill Education Private Limited, 2009.
- [11] Puneet and Naresh Kumar Garg, "Binarization Techniques used for Grey Scale Images," International Journal of Computer Applications (0975 – 8887) Vol. 71, No.1, June 2015.
- [12] Savita Agrawal, Deepak Kumar Xaxa, "Survey on Image Segmentation Techniques and Color Models," International Journal of Computer Science and Information Technologies, ISSN: 0975-9640, Vol. 5 (3), 2014.
- [13] A. M. Khan, Ravi. S, "Image Segmentation Methods: A Comparative Study," International Journal of Soft Computing and Engineering (IJSCE) ISSN:2231-2307, Vol.3, Issue 4, September 2017.
- [14] Sezgin and B. Sankur, "Survey over image thresholding techniques and quantitative performance evaluation," Journal of Electronic Imaging 13 (1), 2004, pp. 146–165.
- [15] Tim Vitale, "Digital Image File Formats and their Storage -- TIFF, JPEG & JPEG2000," Vol. 20, Feb, 2015,
- [16] Liu Chien-Chih, Hang Hsueh-Ming, "Acceleration and Implementation of JPEG 2000 Encoder on TI DSP platform," IEEE International Conference on Image Processing (ICIP) 2007, Vol. 3, pp. 329-339.
- [17] ISO/IEC 15444-1:2000(E), "Information technology-JPEG 2000 image coding system-Part 1: Core coding system," 2020.
- [18] Jian-Jiun Ding and Jiun-De Huang, "Image Compression by Segmentation and Boundary Description," Master's Thesis, National Taiwan University, Taipei, 2021.
- [19] G. K. Wallace, "The JPEG Still Picture Compression Standard," Communications of the ACM, Vol. 34, Issue 4, 2020, pp. 30-44.
- [20] James Bruce, Tucker Balch, Manuela Veloso, "Fast and Inexpensive Color Image Segmentation for Interactive Robots," Proceedings of the 2021 RSJ International Conference on intelligent Robots and Systems.
- [21] Dibya Jyoti Bora, Anil Kumar Gupta and Fayaz Ahmad Khan, "Comparing the Performance of L*A*B* and HSV Color Spaces with Respect to Color Image Segmentation," ISSN 2250-2459, Vol. 5, Issue 2, FEBRUARY 2021, pp. 192-204.
- [22] K. Bhargavi and S. Jyothi, "A Survey on Threshold Based Segmentation Technique in Image Processing," International Journal Of Innovative Research & Development, November 2022, pp. 234-239.
- [23] Kamal A. ElDahshan, Mohammed I. Youssef, Emad H. Masameer and Mohammed A. Mustafa, "An Efficient Implementation of Acute Lymphoblastic Leukemia Images Segmentation on the FPGA," Advances in Image and Video Processing Vol. 3, Issue 3, JUNE, 2022, pp. 8-17.
- [24] Jay Patel and Kaushal Doshi, "A Study of Segmentation Methods for Detection of Tumor in Brain MRI," ISSN 2231-1297, Vol. 4, November 2023, pp. 279-284.