

Inverter design using high frequency

Chandrakant R Shinde¹, Gopal R Shinde²,

¹ Assistant Professor, Electrical Engineering Department, Matoshri College of Engineering & Research Centre, Nasik, Maharashtra, India

² Senior Production officer, Production Department, Binani 3B Glass Fibre Limited, Goa, India

ABSTRACT

In this paper we are developing inverter which is very cheap in cost and portable we are using 50KHz frequency for DC Technique and output 250V DC, 500mA, 100watt and then by level shifting and full bridge converter topology we are converting it into 220AC with the frequency of 50Hz. DC to AC power inverter is commonly used in uninterruptable power supply, Lighting, fan and other applications. This method has disadvantages like large size, large weight and costly so, it will be advantageous to minimize size, weight, and cost and improve overall efficiency. In which we are developing an inverter which is to be light in weight, compact and highly energy efficient. This can possible with the help of High Frequency Inverter; hence we have selected this project. We have used push pull convection and full bridge conversion topology.

Keyword: - Inverter, High frequency, design.

1. INTRODUCTION

We are converting DC to AC (Square wave) with the help of switching device like MOSFET and then again converting it into DC by the process of rectification by high frequency technique. We are doing this to get compactness and to become economical. There are lot of applications like laptop charging, Domestic & commercial lighting. We have used IC SG3525 which will set the oscillator frequency also by pulse width modulation we get controlled constant voltage. There are lot of advantages behind choosing high frequency technique. We have also used ferrite transformer because normal transformer substantial losses at high frequency operation instead, Ferrite reduces losses and its cost is much less. We are using this IC SG3525 for two purposes. Generating 50 KHz frequency and 50 Hz.

2. MATERIAL SELECTION

Here we are going to used special integrated circuit for high frequency name as IC SG3525 for two purposes. Generating 50 KHz frequency and 50 Hz frequency.

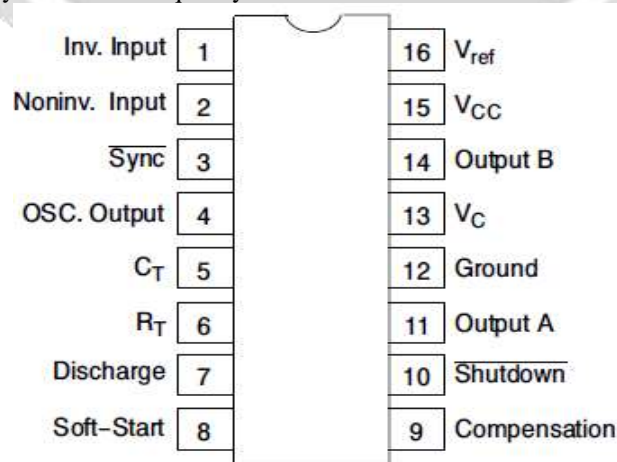

Fig -1: Pin diagram of IC SG 3525

2.1 Ferrite Transformer

The selection of magnetic core materials for a particular inductor or fly back transformer application can be very confusing. Each magnetic material has inherent advantages and disadvantages. Attributes such as permeability, core loss, saturation flux density, winding losses caused by fringing flux, electromagnetic emissions and costs all need to be considered. The objective often is to choose a core material that will result in a design with the lowest cost component, that supplies enough inductance to filter high frequencies or store energy, functions with an acceptable temperature rise and does not emit electromagnetic interference. Marrying inexpensive soft ferrites that have low core loss with inexpensive iron powder that have distributed air gaps in a composite core is a great way to meet such objectives. Ferrite are ceramic compound of the transition metal with oxygen, which are ferromagnetic but non conductive. Ferrite that are used in transformer of electromagnetic core contain nickel, zinc and manganese compound. Ferrite core is a type of magnetic core made of ferrite on which the winding of electric transformer and other wound components like inductor are

2.2 Design of Ferrite and Windings

For designing consider 12A current as input in place of 10A to reduce losses $\gamma=3.14$.

- Input voltage=9.5V.
- Input current=12A
- Output voltage=240V.
- Output current= 500mA.
- Output wattage= 100W
- Turns ratio= $\frac{V_2}{V_1} = \frac{220}{9.5} = 24$
- Primary Impedance = $\frac{V_1}{I_1} = \frac{9.5}{12} = 0.79 \Omega$
- Primary inductance=impedance

$$2 \times \pi \times f \times L = 0.79$$

$$2 \times 3.14 \times (50 \times 10^3) \times L = 0.79$$

$$L_1 = 2.3 \mu H$$

$$Q = 2 \times \pi \times f \times \frac{L}{R}$$

Where Q is inductance factor, we assume 1Turn=300nF. According to this, we are taking primary no. of Turns =3.

$$(1 \text{ Turn})^2 = (300 \times 10^{-9})$$

$$(3 \text{ Turn})^2 = (270 \times 10^{-9})$$

$$\frac{V_2}{V_1} = \frac{N_2}{N_1}$$

$$24 \times 3 = N_2$$

$$N_2 = 72$$

- Secondary inductance

$$L_2 = (N_2/N_1)^2 \times L_1 = (72/3)^2 \times (2.7 \times 10^{-6}) = 1.55 \text{mH}$$

2.3 Filter Design

Filter is necessary to minimize the ripple from output current. Assume minimum current through the filter chock is 0.1A, because the filter choke is always designed for minimum

$$V_0 = 220V, f = 50\text{KHz}, L = ?$$

$$L = \frac{V_0(1-D)T}{(\Delta I)} = \frac{220 \times (1-0.95) \times (10 \times 10^{-6})}{(0.1)} = 1.1\text{mH}$$

Assume Ripple to be 2.22% means $220 \times 0.022 = 5V$

$$P = 0.50.5 \times C \times V^2 \times f$$

$$100 = 0.5 \times C \times 5^2 \times (100 \times 10^3) \quad C = 80\mu F.$$

3. WORKING OF DC TECHNOGY

- When supply is given to pin no. 13 & pin no.15, the circuit capacitor connected to the pin no. 8 of the IC starts charging to provide safe starting of the IC and then IC starts working.
- The supply from battery is provided to the pin no .13 and 15 as well as to centre tap Ferrite transformer.
- The pin no. 13 and 15 will power output pin no. 11 and 14 to generate pulses to drive MOSFET. When MOSFET get drive pulse from pin no. 11 and 14 they start switching.
- Due to switching action, the current from battery flow in the primary of the ferrite transformer will change and due to magnetic coupling action emf get induced in the secondary winding.
- Then, we will get AC supply which will rectified through ultrafast recovery diode (rectification circuit) and we will get DC voltage which will be filter out through filter circuit.
- The shunt regulator is connected in parallel with filter circuit to sense the change in current and voltage.
- This signal is then fed to the inverting terminal of an error amplifier which will compare the inverting input with the non inverting input and output of this error amplifier is given to the input of Schmitt trigger and output of this Schmitt trigger is then fed to the compensation to provide smoothness to output voltage.

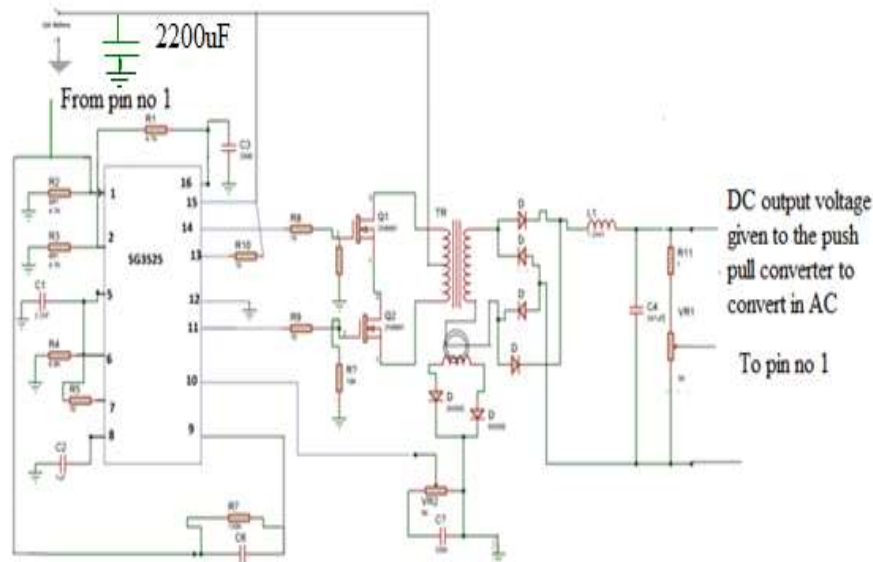
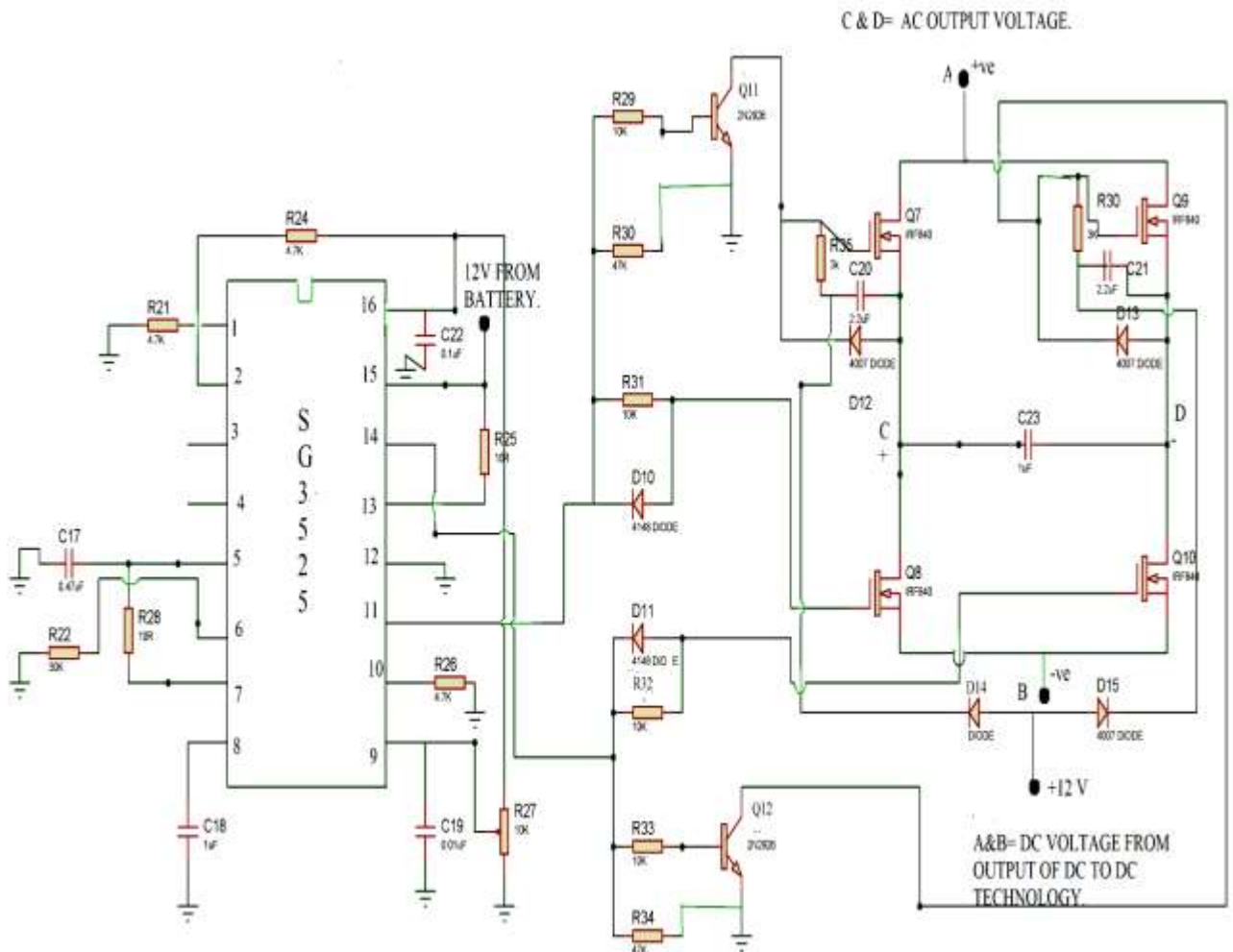

Fig -2: Working of DC Technology

4. WORKING OF DC TO AC TECHNOLOGY.

- The supply from battery (12V) is supplied to the Pin no.13 &15, which starts the operation of IC in soft manner.
- This IC develops 50Hz frequency and Pin no.11&14 fed the pulses to the MOSFET for switching.
- However the pulses are fed one by one to avoid short circuit for that dead time is provided between the switching instant.
- Now suppose first Pin no.11 has fed pulses to the transistor (Q₁₁) and MOSFET (Q₈). Due to which they becomes ON.
- When transistor (Q₁₁) becomes ON then cathode current develop voltage drop across the MOSFET (Q₇) and charge the capacitor. At the same time 12V supply voltage from battery and transistor voltage drop the forces the MOSFET (Q₇) to be OFF.
- At the same time 12V from battery is given to the MOSFET (Q₉) and it becomes ON.
- Due to which MOSFET (Q₈) & MOSFET (Q₉) starts switching the 250V DC voltage and hence we get the half cycle AC Output with the Process of full bridge rectifier.
- For the next Half cycle the Pin no.14 starts feeding the pulses thus transistor (Q₁₂) & MOSFET (Q₁₀) becomes ON.
- Same process is happened as far discussed, then MOSFET (Q₁₀)& MOSFET (Q₇) switch the 250V DC output and by full bridge we get another Half cycle.
- Thus we get 250V AC output. If we changed the DC output then AC output will also changed.
- We are connected small value of capacitor for filtration of AC output



5. CONCLUSIONS

- We have seen the performance of the IC SG3525 pulse width modulation. The output of this IC is square wave and its amplitude is according to supply voltage (12V BATTERY).
- We also observe the frequency which is set by the IC as per designed.
- We have also checked the output voltage of DC Technique as well as DC to AC Technique and we are getting successful results.
- Due to High frequency, our circuit has become compact, light in weight and economical.
- With the Process of full bridge converter and level shifting we have got the AC output voltage and the cost required for circuit is very less for 100W.
- We have also checked the designed component, which is working properly even though MOSFET performance specially heating is very less and efficient.
- By the costing Sheet, our circuit has become cheaper and efficient

6. REFERENCES

- [1] P. T Krein, "High Frequency link inverter based on multiple carrier PWM"
- [2] Sibylle Dieckerhoff, Michael J. Ryan and Rik W. De Doncker "Design of an IGBT-based LCL-Resonant Inverter for High-Frequency Induction Heating" 1999 IEEE
- [3] K. Mauch "Transistor Inverters for Medium Power Induction Heating Applications", IEEE IAS 1986, pp. 555-562
- [4] E. J. Dede, V. Esteve, J. Jordan J. V. Gonzalez, D. Ramirez: "Design
- [5] Considerations for Induction Heating Current Fed Inverters with IGBTs Working at 100 kHz", IEEE APEC Conference Record 1993, pp. 679-685
- [6] Lakshminarayanan.V, 2Anand.B,3 Balakrishnan. P.A. " Analysis and Design of ferrite core transformer for high voltages ,high frequency which is used in ozonators" ISSN 2305-8269
- [7] Chrysis, G. 1989. *High frequency switching power supply*. McGraw Hill, New York, NY, USA

BIOGRAPHIES



Author¹, Mr. Shinde C.R. currently working as a Assistant Professor at Matoshri college of Engineering, Nasik and he has a five year of experience in teaching field & Pursuing his Master of Engineering in Electrical & Electronics from Sant Gadge Baba Amravati university, Completed BE from Dr. Babasaheb Ambedkar University Aurangabad and successfully completed diploma from government college of polytechnic Washim.