

# LOW COST WATER PURIFIER FOR RURAL AREAS.

Ekta Bagde<sup>1</sup>, Aditya Kuthe<sup>2</sup>, Praful Wanjari<sup>3</sup>, Mitali kharbade<sup>4</sup>, <sup>5</sup>Prof. Jayant Dorve.

<sup>1234</sup>Student, Department of Electronics & Telecommunication Engineering, Priyadarshini J.L. College of Engineering, Nagpur, India.

<sup>5</sup>Assistant Professor, Department of Electronics & Telecommunication Engineering, Priyadarshini J.L. College of Engineering, Nagpur, India.

## ABSTRACT

*This paper is about making a water purifier of low cost for rural areas by using Arm7 controller for the betterment of rural areas. In this areas they are dealing with the problems like lack of water and unpurified water. This also causes the health diseases. In this project we will use natural purifying technique called "Biosand". The power required for this system will be given by solar panel. Which will run all the circuitry of our system. The water will be provided by coin based system. One has to insert coin and water will be provided. As per our literature survey on purifying water we found different technique to purify water such as , using solar energy, using chemical water treatment, though this processes took time to purify water as well as this were not healthy to drink because of chemicals, Therefore we are using the biosand method of purifying water. As its maintenance will be less it is low cost and will provide water to group of people by common means.*

**Keyword:** - natural water, water treatment, solar, lowcost, Biosand etc.

## 1. INTRODUCTION

The paper aims at making a system that will provide safe water in adequate quantity effectively at low cost. This purifier will work according to the instructions given to the processor. There will be unpurified water at the input and purified water at the output. The project will be capable of providing water in rural areas in large quantity according to requirement of drinking water of an individual houses or and community. It will work according to the user command given to controller through the pressure sensor. Once the project is made there is no need to control the project manually only we have to give input to it as an coin it will provide purified water.

Here we are going to use solar panel for power because it is low cost water purifier, and Arm-7 controller as an basic component to controller the circuit and two sensors. There will be motor to fetch the water and tanks to store it, as well as the valves to controller the flow of water. In this project water will be store in main tank which is connected to purifier. This purified water is further pass to output tank . External input is given as a coin to pressure sensor which will turn ON the valve and purified water will be provided.

## 2. LITRATURE SERVEY

**2.1, "Clean and Cost Effective Industrial Wastewater Treatment Technology for Developing Countries", International Journal of Scientific and Research Publications, Volume 5, Issue 12, December 2015.**

Author's paper deals with irradiative treatment of contaminated water with high dose of gamma rays . In this process of water purification they performed five steps. With the use of sulphuric acid they adjusted the pH value waste water of acidity adjustment. now hydrogen peroxide and ferrous sulphate are used to perform Fenton reaction which is a oxidation process. As initiator only trace amount was added. Then the gamma irradiation and sample irradiated was conducted in gamma chamber at room temperature. According to the mark the sample was filled into one liters bottle glass. Then the following doses were irradiated:0 kGy,1 kGy,2 kGy,3 kGy,.....18 kGy respectively. Now for alkaline sedimentation process the samples were carried out, after irradiation process. For next process, the pH value of sample was adjusted to value not less than 10 with calcium hydroxide for perform centrifuge method and sedimentation with gravity. For the purpose of color removal activated carbon filtration is used which is the final step of this experiment. As gamma radiation is helpful in purification of industrial waste water because they have lots of waste deposits as well as bacteria but for the normal use of water purification cannot be done with gamma radiation because it is harmful to health [1].

## **2.2 “Low-cost solar water purifier for rural households” ,Nimbkar Agricultural Research Institute (NARI) Phaltan, Maharashtra, India.**

Author have discussed about technique of water purification with the help of solar energy. They used simple solar device to purify the water in their system. They started heating water using tubular solar collector. All the harmful deposits were eliminated by heating water using solar technique but they have to heat the water until the next morning to a desired temperature. Then they have to collect it next morning. As in this process the water purification method takes a lot of time. This method is also no useful for the rainy seasons or the season where there is low temperature . Therefore this time required is very much as if we want a purifier which has fast service. They also surveyed how many days there will be the temperature above 45 degree and analysis [2].

## **2.3 “Various method involved in water treatment to control water pollution”. Department of chemistry , J.L Charturvedi College of Engineering, Nagpur, India.**

Author proposes various methods involved in waste water treatment to control water pollution. In this paper they have discussed about different characteristics of water that is physical, chemical, biological and radiological characteristics. They founded the physical characteristic as temperature, turbidity, and color. The another characteristic was chemical characteristics of water which includes pH levels hardness, and dissolves solids. Biological characteristics were having algae bacteria protozoan and viruses. They have also differentiates different parameter of natural water and waste water. What pollution was caused by the industries in water.

There were also different methods available for treatment of hazardous wastes water treatment such as thermal and fixation method. They have also some a survey by year wise on the amount of water pollution by the states[3].

## **3. PROBLEM STATEMENT**

India lives in villages, and more than 65% of our population with hundreds of millions of people are still living and working in rural areas and villages across India. The health of the Rural India is the barometer of the health of India itself. Rural India has its own set of challenges, and the top among them is the availability of Pure drinking water. Among the top 3 needs of humans – Food, water and Shelter, Water is the most affected part of our lives, with contamination affecting 95% of our water resources. Drinking water accounts for at least 35% of all diseases affecting the rural India. India spent about 135,000 Crores Rupees in its last Five year plan to take care of this problem. The worst affected people are Children and women, who bear the brunt of this contamination, and though a lot of work is being done to elevate our rural India from this menace, we have just scratched the surface so far.

## **4. PROPOSED IDEA:**

In this system we are using natural resources to purify the water for the use of rural areas .in this paper we are going to use Arm7 for controlling the process of providing purified water. First we will collect unpurified water

and then purify it with the help of natural recourses then we will use solar as a power to run our device that it could provide the purified water. As in many rural areas there is a lack of water and if they try to bring water for their use by purchasing it, this will increase the cost. Therefore we are making a device that could give the purified water at very low cost. Say for 1rs it will provide 4 liters of water. The water will be provided after inserting a coin as discussed in methodology.

## 5. BLOCK DAIGRAM:

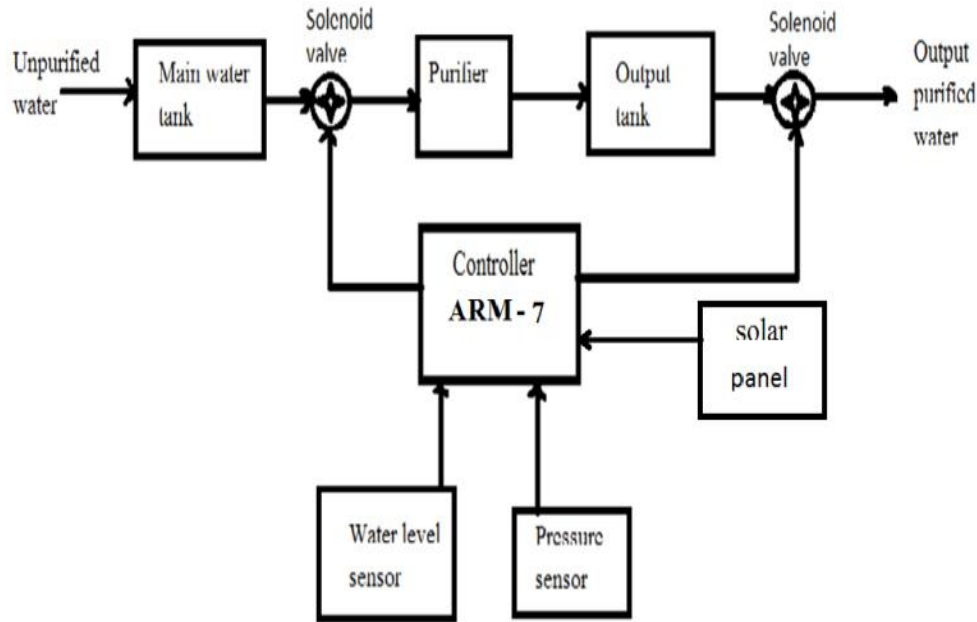

Fig. Block diagram

Fig-1. Block diagram.

### 5.1 WORKING:-

When coin is inserted in box which contains pressure sensor, it will sense pressure of coin. After this the bottle or any container will be placed below the tap which has the motion detector. After detecting the container the controller will send the command to open the valve that will provide the water. Earlier we have assumed that the water tank was full with the purified water, then if the tank gets empty more than 50% then the controller will send the signal and make the valve off. Basically there will be three level sensors on 25%, 50% and 90%. Therefore there will always be water in the main tank. All of these processes will be based on solar power to run the system, and we can also run the system on external power. In this way the water in the purified water tank will be provided. The purified water tank contains two level sensors to sense the level of the water, whether it is low or high. If the water level is low, then the valve of the main tank which contains unpurified water will be in ON condition and the water will pass to the purifier. If the water level is high in the purified tank, then the valve of the main tank will be in OFF condition.

### 5.3 FLOW DAIGRAM

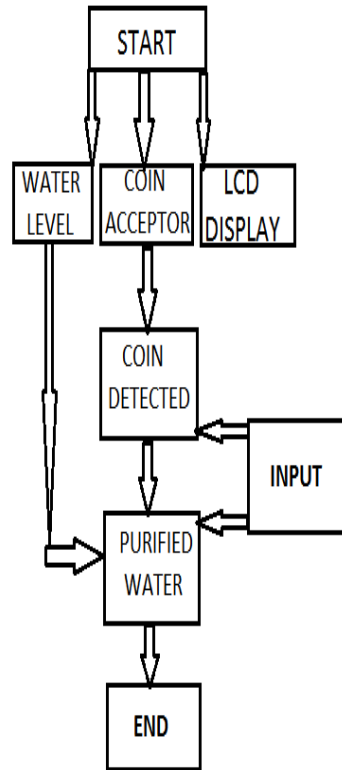

**Fig-2.** Flow diagram.

### 6. CONCLUSIONS

As per the whole survey we have proposed a Low Cost Water Purifier for rural area using Arm7. It has applications to be placed at rural areas or the transport station at very low cost. This system is capable of providing purified water in adequate quantity. It can be placed at the community uses also. This system reduces the complexity of the circuit and it also reduces the manual work and also keep us away from deceases.

### 7. ACKNOWLEDGEMENT

It is a great presumption to ascribe our success to our own management, and not to esteem ourselves upon any blessing rather as it is the bounty of heaven, then the acquisition of own prudence. We take this opportunity to express profound gratitude and deep regards to our guide Prof. J. Dorve for this exemplary guidance and monitoring.

### 8. REFERENCES

[1] Mr. TunTunNaing\*, KhinKhinLay, "Clean and Cost Effective Industrial Wastewater Treatment Technology for Developing Countries", International Journal of Scientific and Research Publications, Volume 5, Issue 12, December 2015.

[2] Mr. Anil K. Rajvanshi and Amol Dalvi, “ Low-cost solar water purifier for rural households”, Nimbkar Agricultural Research Institute (NARI) Phaltan, Maharashtra, India , May-2015 ISSN: 2278-2834, p- ISSN: 2278-8735. Volume 9, Issue 4, Ver. V (Jul - Aug. 2014), PP 13-20.

[3] Mr. S.S Turkar, D.B Bharti and G.S Gaikwad. “various method involved in water treatment to control water pollution”. Department of chemistry, J.L Chaturvedi College of Engineering, Nagpur, India.

