

MICROPROCESSOR BASED SLIP POWER RECOVERY IN INDUCTION MOTOR

Rushabh Dodke¹, Shareyu Bhad², Umesh Lahudkar³, Mayur karpate⁴
Nikita Vyawahare⁵, Darshana Bhajikhaye⁶, Prof. Mr. Prasanna Titarmare⁷

¹ Rushabh Dodke, Electrical Engineering, KDKCE, Maharashtra, India

² Shareyu Bhad, Electrical Engineering, KDKCE, Maharashtra, India

³ Umesh Lahudkar, Electrical Engineering, KDKCE, Maharashtra, India

⁴ Mayur Karpate, Electrical Engineering, KDKCE, Maharashtra, India

⁵ Nikita Vyawahare, Electrical Engineering, KDKCE, Maharashtra, India

⁶ Darshana Bhajikhaye, Electrical Engineering, KDKCE, Maharashtra, India

⁷ Prof. Mr. Prasanna Titarmare, Electrical Engineering, KDKCE, Maharashtra, India

ABSTRACT

Slip power recovery slip ring induction motor drives are used in limited speed range, high power applications where control of slip power provides the variable speed drive system. The speed of the motor is control by various methods such as three variable rheostat of same rating used at the output slip terminals of different phases. Second is converting AC slip power to DC but the problem of poor drive efficiency remains the same. To avoid this losses third method is designed named as static Kramer drive system. This paper describes the energy saving in large electric drives by using implementation of "Slip Power Recovery System".

Keyword : - Slip power recovery system, Synchronous power, Power loss due to heat.

1. INTRODUCTION

Induction motor drives with control of speed have huge applications in modern industrial set up . More than 75% of load today in the industry of an country consists of induction motor drives. Induction motor drives have found great applications due to easily available slip power from slip rings and can be utilized mechanically or electronically for better speed control. Instead of wasting power in resistance slip power can be recovered from static converts. High performance induction motor drive application requires low cost, high efficiency and simple control circuitry for complete speed range. The slip power recovery system comprising static kramer drives provides speed control of slip ring induction motor below synchronous speed. In this system, a portion of power available at rotor is brought outside at very low frequency i.e. slip frequency & is converted into dc using three-phase bridge rectifier. The dc is filtered & fed to inverter whose firing angle is set to minimum value of 90°. This power is then transferred to source using recovery transformer. As the flow of power from rotor to rectifier is unidirectional due to diode bridge, power can flow from rotor to bridge-side only. Thus only sub-synchronous speed control is possible. Use of diode rectifier on rotor side & inverter on source side not only injects harmonics, low power factor & creates other power quality problems power source. To overcome such problems many techniques have been suggested in this literature. This paper is study of those techniques & look into latest trends for remedies of problems.

2. METHODS

There are two methods which are used for the speed control of the slip ring used very much.

2.1 Doubly-fed machine speed control by rotor resistance

This method is simple of speed control of a wound rotor induction motor is by mechanical variation of the rotor circuit resistance at output slip terminals. By varying the rheostat the speed of the motor can be controlled. But this method is very inefficient because slip energy is wasted in the rotor circuit resistance.

2.2 Speed control by converting AC to DC

In this method the external resistance in the rotor circuit can be varied statically by using a diode-bridge rectifier and chopper as usual the stator of the machine is connected directly to the line supply. The dc voltage is converted to current source by connecting a large series inductor then it is connected shunt resistance. When the IGBT is ON the resistance is short circuited and the current is bypassed through it. On the other hand if the IGBT is OFF the resistance is connected in the circuit and current flow through it. So the developed torque and the speed can be controlled by the variation of the duty cycle of the chopper. But in this method the problem of poor drive efficiency is same. Therefore this method has been used where the efficiency is not great concern.

2.2 Modified Static Kramer Drive System

In this method the slip power recovery scheme for Induction Motor speed control. The slip power recovery (SPR) drive is an external system connected to the rotor circuit in place of the external resistors. The SPR provides speed and torque control like resistors but can also recover the power taken off the rotor and feed it back to the power system to avoid energy waste.

In an SPR drive consists of two interconnected power converters. The slip power recovery drive that permits only a sub-synchronous range of speed control through a converter cascade is known as a modified static Kramer drive. In this modified static kramer model circuit some modifications are there at the output. The slip terminal are connected to the drive rectifiers that converted three phase ac slip power into dc and an inductor is connected in series and the current through the inductor is applied to the inverter that convert dc in to the form of 3 phase ac voltage. With the use of inverter the speed of the slip ring motor can be controlled easily by changing firing angle of the microprocessor devices. In all methods the output voltage and frequency amplitude of IM is changed and less than the input voltage and frequency due the slip. So to set the voltage and frequency of output. The output voltage is given to the step up transformer that increases the amplitude of voltage. For the variation of firing angle in inverter frequency is changed. After that the feedback power given to the main supply. Hence we can reduce all losses due to slip and the speed of motor can also be controlled easily by the drive system. The speed and current feedback signals are obtained by connecting tachogenerator to the motor shaft. After digitizing, these signals are fed to the microprocessor where they are compared with respective reference signals. The firing pulses generated by the microprocessor are fed to the inverter through driver circuit.

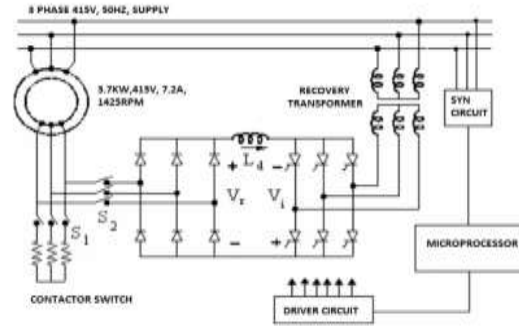

Fig -1: Slip power recovery system

3. EQUATIONS

Considering the equivalent circuit, if the injected voltage is increased, the rotor current will be reduced, resulting in a reduction in the available torque generated by the motor. If there is a load applied to the motor, the rotor will slow down, resulting in an increase in slip. As slip increases, the effective voltage seen by the stator will be reduced (the actual voltage physically induced in the rotor, due to the stator, will increase). As a result, rotor current will increase. This process allows the machine to find a new steady state where the induced rotor current produces enough torque to equal the load torque.

In order to simplify the analysis, assume that the magnetising reactance can be moved to the terminals of the equivalent circuit. (If this is not the case, the stator phase voltage, stator impedance and magnetising reactance can be replaced by a Thevenin source and impedance. Simply replace subscript "s" in the following analysis with subscript "TH").

If the injected voltage is in phase with the rotor current, then the voltages in the equivalent circuit may be written as

$$V_s = \bar{I}_R \left(R_s + \frac{R_R}{s} \right) + \frac{V_i}{s} + j\bar{I}_R (X_{Ls} + X_{Lr})$$

$$V_s^2 = \left(I_r R_s + \frac{I_r R_r + V_i}{s} \right)^2 + I_r^2 (X_{Ls} + X_{Lr})^2$$

$$V_s = \frac{I_r R_r + V_i}{s} \angle \theta_r + I_r (X_{Ls} + X_{Lr}) \angle (\theta_r + 90^\circ)$$

3.1 Power and Torque

The air gap power of the machine may be written as

Breaking this equation into parts, it can be seen that the air gap power is the sum of resistive losses, power recovered through the slip rings and the mechanical power.

$$P_{gap} = 3I_r^2 R_r + 3I_r V_i + 3I_r (I_r R_r + V_i) \frac{(1-s)}{s}$$

Using the expression for air gap power, the torque may be written as

$$\tau = 3I_r \frac{(I_r R_r + V_i)}{S \omega_s}$$

Now, substituting the slip expression into the torque expression gives the result that torque is only a function of rotor current, not slip or injected voltage:

$$\tau = \frac{3I_r}{\omega_s} [(V_s - I_r^2 (X_{ls} + X_{lr})^2)^{1/2} - I_r R_s]$$

The expression above means that for a given torque, the rotor current will always be the same, independent of speed. Analysing the torque equation, this in turn means that for a given constant value of torque

$$\frac{(I_r R_r + V_i)}{S}$$

will be constant. The injected voltage required to adjust the slip at a given load can be found from this expression.

3.2 No-Load Condition

Consider again the expression for slip:

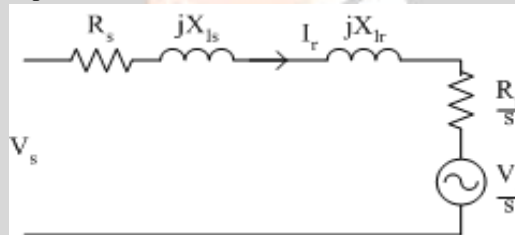

$$S = \frac{V_i + I_r R_r}{(V_s - I_r^2 (X_{ls} + X_{lr})^2)^{1/2} - I_r R_r}$$

If the torque is zero, then the rotor current will also be zero and at zero torque, the slip is given by

$$S_0 = \frac{V_i}{V_s}$$

3.3 Efficiency

Since some of the power supplied to the motor is recovered from the rotor circuit, the efficiency cannot be calculated as simply output power over input power. Instead, in a slip energy recovery drive the efficiency is

$$\eta = \frac{P_{out}}{P_{in} - P_{recovered}}$$

3.4 Static Kramer Drive

A static kramer drive is a method to obtain an injected voltage that is in phase with the rotor current. The schematic circuit for a static kramer drive is shown below

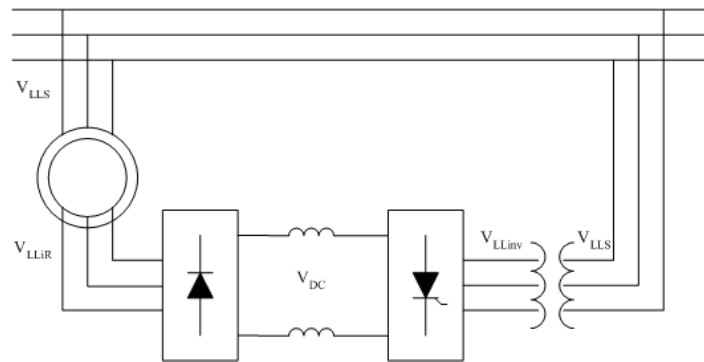

Fig -2: Static Kramer Drive

The voltage at the slip rings is forced to be in phase with the rotor currents by the diode rectifier. The magnitude of the slip ring voltage is set by the DC link voltage, which is in turn set by the inverter connected back to the AC supply. In the diagram above and the analysis presented, the inverter used is a thyristor converter. However, a PWM inverter can also be used.

3.5 Simple Analysis

This simple analysis of the static kramer drive illustrates the operation of the drive. It neglects the voltage drops in the drive and any possible commutation overlap in the diode rectifier.

The voltage at the input to the diode rectifier is given by

$$V_{LLiR} = \sqrt{3} \frac{V_i}{\alpha_{eff}}$$

and the dc link voltage can be found from the diode input line-line voltage as

$$V_{DC} = \frac{3\sqrt{2}}{\pi} V_{LLiR}$$

Considering the thyristor converter, this circuit can be thought of as a thyristor rectifier connected in reverse, and the DC link voltage is related to the line-line inverter voltage as

$$V_{DC} = \frac{-\sqrt{2}}{\pi} V_{LLiR} \cos \alpha = \frac{\sqrt{2}}{\pi} V_{LLinv} |\cos \alpha|$$

Substituting the above expressions, the voltage injected into the rotor can be calculated as

$$V_i = \frac{\alpha_{eff}}{\sqrt{3}} V_{LLinv} |\cos \alpha|$$

In the case that the inverter line-line voltage is connected to the supply through a transformer, as shown in the diagram above, the injected voltage can be related to the supply voltage as

$$V_i = \frac{\alpha_{eff}}{\sqrt{3}} \frac{N_{inv}}{N_{line}} V_{LLS} |\cos \alpha|$$

Using this simplified analysis together with the slip energy recovery torque equations, the thyristor firing angle required for a particular torque at a particular speed can be found. If necessary, more detailed analysis can be carried out by repeating the above process, but including device voltages and commutation overlap.

3.6 Torque-Speed

Because the slip ring voltage is derived using a diode bridge, the torque speed curve for a motor operated using a static kramer drive does not produce a negative torque as soon as the speed exceeds the no-load speed. If the slip is too low for a given injected voltage, the voltage induced in the rotor circuit by the stator will have a lower magnitude than the DC link voltage. As a result, no rotor current will flow and the torque will be zero.

4. CONCLUSIONS

In this paper, different methods has been put forward in design of three phase slip ring induction motor. The wasted slip energy in rotor circuit resistances like losses of power into heat is removed and slip power is recovered. The power drive efficiency is increased and used in intermittent speed controlled applications at any speed range.

5. REFERENCES

- [1]. Ajay Kumar, S. K. Agrawal, L. M. Saini, and Ashwani Kumar, "Performance analysis of a microcontroller based slip power recovery drive" International Journal of engineering, science and technology volume 3, No.3, 2011
- [2]. Jagendra Singh, Swati Rani, Rohini, "Slip Power Recovery System In Three Phase Slip Ring Induction Motor" IOSR Journal of electrical and electronics Engineering(IOSR-JEEE)-2014
- [3]. Shiv Kumar, Ajay Kumar, Himanshu Gupta, "Comprehensive Analysis Of Slip Power Recovery Scheme" IJIRT Volume 2 Issue 1 ISSN:2349-6002 JUNE 2015.
- [4]. B. K. Singh and K. B. Naik, "Steady State Modelling and Performance Analysis Static Slip Energy Recovery Controlled Slip Ring Induction Motor Drive" proceedings of the international multiconference of engineers and computer scientists 2009 vol II IMECS 2009, March 18-20, 2009 Hong Cong.
- [5]. Shiv Kumar , Ajay Kumar , Himanshu Gupta , "Comprehensive analysis of slip power recovery scheme" June 2015 | IJIRT | Volume 2 Issue 1 | ISSN:2349-6002.