

Optimization of Air Conditioning by weight reduction using static and model analysis

¹Ms. Salunke Priyanka Arjun, ²Mr.Khandagale Pravin Bharat, ³Mr. Lawand Sagar Shashikant

¹Lecturer,Department of Mechanical Engg. Department,SIET, Polytechnic,Paniv ,Maharashtra,India

²Lecturer,Department of Mechanical Engg. Department,SIET, Polytechnic,Paniv ,Maharashtra,India

³Lecturer,Department of Mechanical Engg. Department,SIET, Polytechnic,Paniv ,Maharashtra,India

ABSTRACT

The air conditioners used in cars are mounted on a bracket in the bonnet. This project intends to analyze the bracket and optimize the weight by replacing the material of the bracket by composite material. Weight reduction will increase the efficiency, though very minute.

Keywords—AC, Bracket, GFRP, ANSYS

1. INTRODUCTION

Consider air conditioning and cooling as unit. Though the air conditioning system and the engine cooling system are two separate systems, they influence one another. Air conditioning system operation places additional load onto the engine cooling system and the coolant temperature rises.

The additives contained in the coolant not only protect against frost, but also against engine overheating. The proper coolant composition increases the boiling point of the medium to above 120 °C. An enormous performance reserve is particularly important in the summer, when air conditioning system and cooling system are heavily burdened by ambient temperatures and long trips. The best approach is to check the coolant during air conditioning service as well.

2.LITERATURE REVIEW

R. P. Kumar, Dr. K Rambabu presented their work on “Study of Design and Analysis of Air Conditioner Compressor Mounting Bracket.” In this work the authors said that, parameters like cost of vehicle and fuel efficiency are mostly influenced by the weight of the vehicle in the automotive industries. As per the safety standards this is very important to design the light weight component. This paper describes the study of the optimized design of the Air-Conditioner compressor mounting bracket. The study of the topology optimization is done as per the requirement of the bracket design. This study also highlights the factors for the failure of the mounting bracket and the effect of the optimization by various analysis.

Harshal Bankar and P. Baskar submitted their study on “Dynamic Analysis of Air Conditioner Compressor Mounting Bracket.” In this study the researchers have said that simulation plays very important role in the automotive industries for the higher levels of quality, better cost effectiveness and quick market response. In this paper, the use of dynamics analysis technique is used for the simulation of the compressor mounting bracket for various vibration loads. The standard testing conditions were used for the testing of the compressor mounting bracket. The results showed that resonance in the dynamic analysis is the major cause for the failure of the compressor mounting bracket, under static analysis, under the same magnitude of load resonance cannot be predicted. Thus, dynamic analysis gives best results for design validation of the compressor mounting bracket.

M. Singh, D. Singh and J. S. Saini presented their study on “Dynamic Analysis of Condenser Assembly of Automobile Air Conditioning System Using CAE Tools.” In this study it is said that with the automotive air-conditioning industry aiming at higher levels of quality, cost effectiveness and a short time to market, the need for simulation is at an all-time high. In this work, the use of dynamics analysis is proposed in the simulation of

the automobile air conditioning condenser assembly for the vibration loads. The condenser assembly has been analyzed using the standard testing conditions. The results revealed that the components of condenser assembly may fail due to resonance in dynamic analysis. Thereafter, the condenser assembly was optimized, resulting in a 2 % reduction in mass.

3. PROBLEM STATEMENT

Weight optimization of the components mounted on the automobile is one of the measure area of study in today's engineering studies. We need to design the compressor support bracket for Ashok Leyland 220 Bus, using different materials including conventional as well as composite materials. We need to find out optimum solution for this application's support bracket even considering material and manufacturing costs.

4. THEORETICAL DESIGN

4.1. Calculation of thickness for Steel Bracket:

Compressor will be installed on the bracket with the help of bolts, which allows us to change the width of the bracket which can be less or more than the width of the compressor. Bolts and base of the compressor may have shape which will help us bolting the compressor to the plate.

This leads to shape of side closed L bracket, Dimension of the bracket will be 450 mm in length and W mm in width which is variable in the design table. All the formulae below are submitted in the design table and best suited width of 100 mm is selected from that design table. Stress calculations for the 100 mm width SS 403 steel plate bracket design is given below.

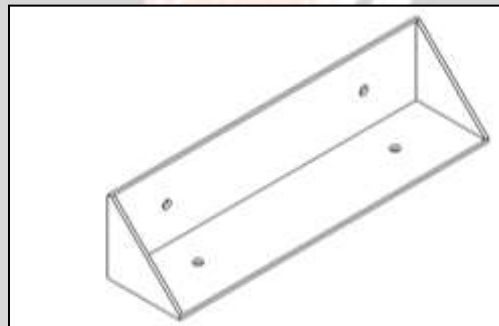

Fig.1. AC Compressor Bracket Final

Following stress needs to be checked
Shear Stress.

Direct and Bending Stress

Let us consider 17.4kg weight on the bracket. Material for manufacturing of bracket is selected as steel. Forces acting on the component installed on automobile are as follows 3g loading in all three directions independently acting on the component when applied on the compressor. Area of the plate under compressor is 450mm by 100mm

So area of plate under the compressor:-

$$A = 450 \times 100 = 45000 \text{mm}^2$$

$$\text{Load acting} = 17.4 \text{kg} \times 3 \times \text{gravetational acce}$$

$$\text{Load acting} = 17.4 \times 3 \times 9.81$$

$$\text{Load acting } L = 512.08 \text{ N}$$

$$\text{Direct Stress} = \frac{512.08}{45000}$$

$$\sigma_{\text{direct}} = 0.0114 \text{ Mpa}$$

So direct stress is negligible.

Design thickness of plate according to shear limit.

Small area under shear is width wise

Which is

$$A_{shear} = W \times t$$

$$A_{shear} = 100 \times t$$

Force = 512.08 N

$$\tau = \frac{F}{A_{shear}}$$

$$\tau = \frac{512.08}{100 \times t}$$

$$\tau_{all} = \frac{5.1208}{t}$$

$$\tau_{all} = \frac{0.5 \times S_{yt}}{FOS}$$

Factor of safety selected as 2

$$\tau_{all} = \frac{0.5 \times 205}{2}$$

$$\tau_{all} = 51.25 \text{ Mpa}$$

Hence

$$t = \frac{5.1208}{51.25} = 0.099 \text{ mm}$$

38 gauge sheet should be selected which is approx 0.152 mm thick. Also we must check thickness according to bending stress. Bending forces acting on base plate are on the centre of compressor or acting downwards. 512 N downward causes couple with distance of 50 mm frame support at cross-section B just near the support bending stress will be caused by 512 N as follows

$$M = F \times \frac{W}{2}$$

$$M = 512 \times \frac{100}{2}$$

$$M = 25600 \text{ N.mm}$$

According to bending we know that

$$\frac{M}{I} = \frac{\sigma}{Y} = \frac{F}{R}$$

σ is maximum when $Y = \max$

Where

$Y =$ distance of stress from neutral axis

$$Y = \frac{t}{2}$$

$$I = \frac{bd^3}{12}$$

$$I = \frac{100 \times t^3}{12}$$

$$\sigma_{all} = \frac{M.Y}{I} = \frac{25600 \times 6}{100 \times t^2}$$

$$\sigma_{all} \times t^2 = 1536$$

$$\sigma_{all} = \frac{205}{2} = 102.5 \text{ Mpa}$$

$$t^2 = 14.985$$

$t = 3.87 \text{ mm}$

Nearest gauge for the mounting is 8

Thickness of the sheet will be 4.176 mm

Weight of the Bracket can be given by the following formulae

Total area of the developed sheet metal will be 2 width and length rectangular areas and 2 end covers with square areas

$$\begin{aligned}At &= 2 \times Al + 2 \times Ab \\At &= 2 \times b \times l + 2 \times b \times b \\At &= 2 \times 100 \times 450 + 2 \times 100 \times 100\end{aligned}$$

$$At = 110000 \text{ mm}^2$$

$$\begin{aligned}\text{volume} &= At \times t \\V &= 110000 \times 4.176 \\V &= 459360 \text{ mm}^3 \\weight &= V \times \rho\end{aligned}$$

Where ρ – Density of SS 403 material which is $8E-06 \text{ kg/mm}^3$

$$\begin{aligned}\text{weight} &= 459360 \times 8E - 06 \\Weight &= 3.675 \text{ kg}\end{aligned}$$

Weight of the designed bracket is 3.67 kg. Natural frequencies of the bracket will be evaluated and mode shapes will be observed in the FEA analysis. Equivalent design with composite material will be done and same FEA will be done on that design to optimize the weight without losing the frequency characteristics of the component.

We also need to verify the vibrational frequencies of the mounting bracket of the AC compressor. First natural frequency of the bracket can be found using the following formulae.

Thickness of AC compressor bracket for GFRP:-

Compressor will be installed on the bracket with the help of bolts, which allows us to change the width of the bracket which can be less or more than the width of the compressor. Bolts and base of the compressor may have shape which will help us bolting the compressor to the plate.

This leads to shape of side closed L bracket, Dimension of the bracket will be 450 mm in length and W 100 mm in width which is variable in the design table. All the formulae below are submitted in the design table and best suited width of 100 mm is selected from that design table. Stress calculations for the 100 mm width GFRP plate bracket design is given below.

Following stress needs to be checked

- Shear Stress.
- Direct and Bending Stress

Let us consider 17.4kg weight on the bracket.

Material for manufacturing of bracket is selected as GFRP.

Forces acting on the component installed on automobile are as follows

3g loading in all three directions independently acting on the component when applied on the compressor. Area of the plate under compressor is 450 mm by 100 mm So area of plate under the compressor:-

$$A = 450 \times 100 = 45000 \text{ mm}^2$$

$$\begin{aligned}\text{Load acting} &= 17.4 \text{ kg} \times 3 \times \text{gravetational acce} \\ \text{Load acting} &= 17.4 \times 3 \times 9.81\end{aligned}$$

$$\text{Load acting } L = 512.08 \text{ N}$$

$$\text{Direct Stress} = \frac{512.08}{45000}$$

$$\sigma_{\text{direct}} = 0.0117 \text{ Mpa}$$

So direct stress is negligible.

Design thickness of plate according to shear limit.

Small area under shear is width wise, which is

Force = 512.08 N

$$A_{shear} = W \times t$$

$$A_{shear} = 100 \times t$$

$$\tau = \frac{F}{A_{shear}}$$

$$\tau = \frac{512.08}{100 \times t}$$

$$\tau_{all} = \frac{5.1208}{t}$$

$$\tau_{all} = \frac{0.5 \times S_{yt}}{FOS}$$

Factor of safety selected as 2

$$\tau_{all} = \frac{0.5 \times 100}{2}$$

$$\tau_{all} = 25 \text{ Mpa}$$

Hence

$$t = \frac{5.1208}{25} = 0.2048 \text{ mm}$$

Also we must check thickness according to bending stress.

Bending forces acting on base plate are on the centre of compressor or acting downwards.

512 N downward causes couple with distance of 50 mm frame support at cross-section B just near the support bending stress will be caused by 512 N as follows

$$M = F \times \frac{W}{2}$$

$$M = 512 \times \frac{100}{2}$$

$$M = 25600 \text{ N.mm}$$

According to bending we know that

$$\frac{M}{I} = \frac{\sigma}{Y} = \frac{F}{R}$$

σ is maximum when $Y = \max$

Where

$Y =$ distance of stress from neutral axis

$$Y = \frac{t}{2}$$

$$I = \frac{bd^3}{12}$$

$$I = \frac{100 \times t^3}{12}$$

$$\sigma_{all} = \frac{M.Y}{I} = \frac{25600 \times 6}{100 \times t^2}$$

$$\sigma_{all} \times t^2 = 1536$$

$$\sigma_{all} = \frac{100}{2} = 50 \text{ Mpa}$$

$$t^2 = 30.72$$

$$t = 5.54 \text{ mm}$$

Thickness of the sheet will be 6 mm

Weight of the Bracket can be given by the following formulae

Total area of the developed sheet metal will be 2 width and length rectangular areas and 2 end covers with square areas

$$\begin{aligned}
 At &= 2 \times Al + 2 \times Ab \\
 At &= 2 \times b \times l + 2 \times b \times b \\
 At &= 2 \times 100 \times 450 + 2 \times 100 \times 100 \\
 At &= 110000 \text{ mm}^2 \\
 \text{volume} &= At \times t \\
 V &= 110000 \times 6 \\
 V &= 660000 \text{ mm}^3 \\
 \text{weight} &= V \times \rho
 \end{aligned}$$

Where ρ – Density of GFRP material which is $2.660 \text{ E-6 kg/mm}^3$

$$\begin{aligned}
 \text{weight} &= 660000 \times 2.660 \text{ E} - 6 \\
 \text{Weight} &= 1.76 \text{ kg}
 \end{aligned}$$

Weight of the designed bracket is 1.76 kg. Natural frequencies of the bracket will be evaluated and mode shapes will be observed in the FEA analysis. Equivalent design with composite material will be done and same FEA will be done on that design too to optimize the weight without losing the frequency characteristics of the component.

According to these calculations different materials are selected and DOE is performed to select the best alternative for the design for the compressor support system links.

- Percentage weight reduction if we use GFRP instead of steel

$$\begin{aligned}
 \% \text{ weight reduction} &= \frac{\text{weight of steel bracket} - \text{weight of GFRP bracket}}{\text{weight of steel bracket}} \\
 &= \frac{3.67 - 1.76}{3.67} \\
 &= 52\%
 \end{aligned}$$

5.FINITE ELEMENT ANALYSIS

According to analytical solutions, it has been calculated that the safe operating load on the given design of Steel AC mounting bracket model is 512.08 Newton. Same loading is applied to the bracket bolt holes where compressor is bolted remotely at approximate location of the compressor C.G.

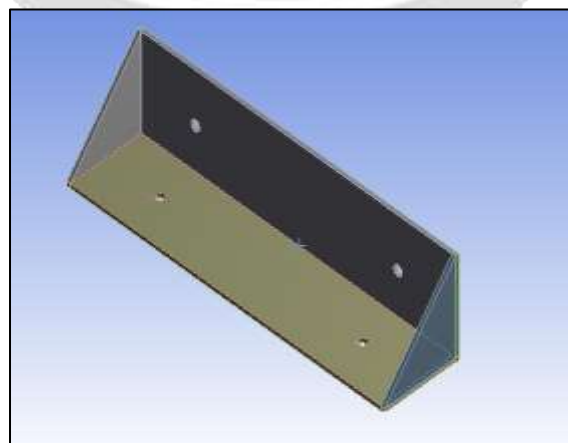

Fig.2.Steel AC mounting bracket

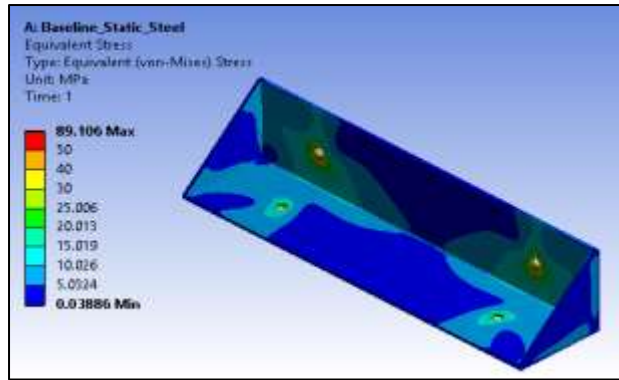

Fig.3.Von Mises Stress plot for Steel AC mounting bracket 1

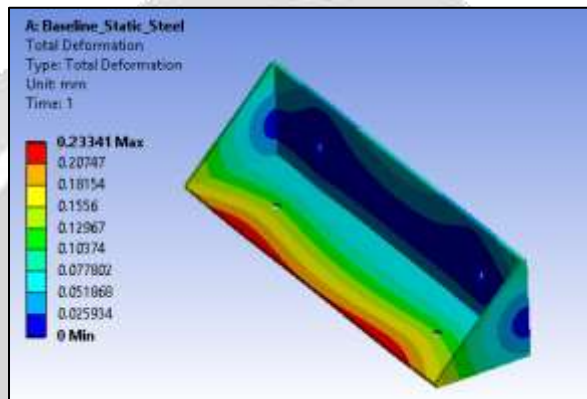

Fig.4.Total deformation plot for Steel AC mounting bracket 1

While building FEA model of GFRP bracket has been modeled using shell with Element type 181 is used for meshing them. Figure below shows the meshed model for the assembly. Standard element size of 1 mm is used for the good results in the analysis. Total of 110783 nodes and 111435 elements are used for the meshing of the model. This small element size selection assures the accuracy of the results.

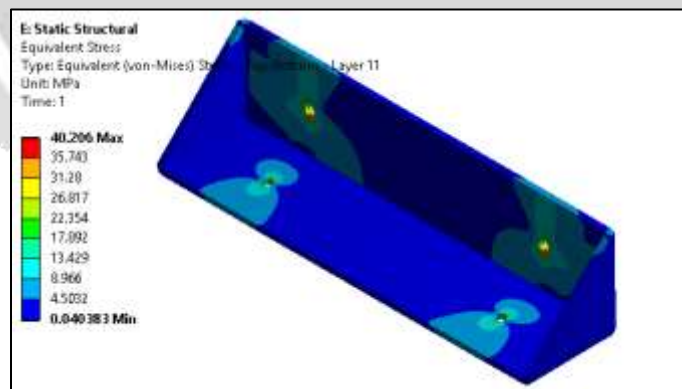

Fig.5.Von Mises Stress plot for GFRP AC mounting bracket1

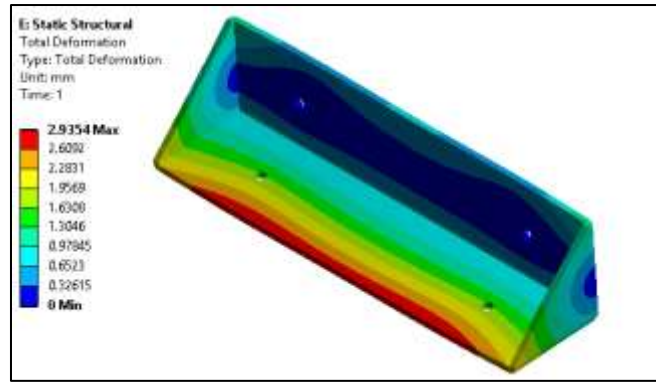

Fig.6.Total deformation plot for GFRP AC mounting bracket 1

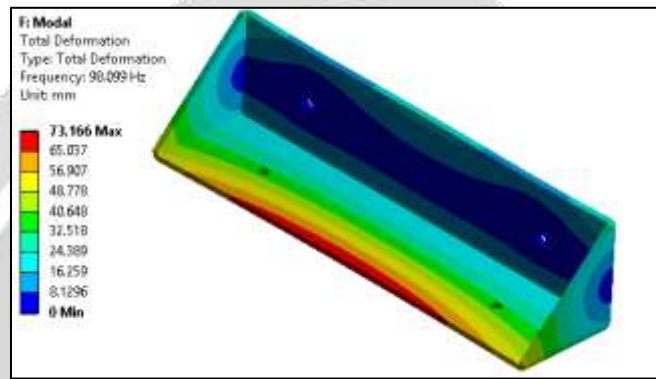

Fig.7.Mode shape plot at 1st natural frequency of steel bracket 98.1 Hz

Plot above shows the mode shape plot for the first natural frequency of the GFRP bracket. That means shape of the deformation is to be studied for the first modal frequency and not the deformation values from the plot do not signify anything.

6. FABRICATION AND TESTING

Parts are fabricated by hand lay-up technique. Molds created using ply wood and GFRP layup angles and adhesive used to create the GFRP final component in the mould. After lay ups are done it is kept under pressure for curing period to settle. After curing period it is taken out as a useful GFRP component. FFT analyzer is used to test the component for its first natural frequency.



Fig.8. Manufacturing process image

7. RESULT AND DISCUSSION

Mode No	Natural Frequency (Hz) GFRP bracket	Natural Frequency (Hz) Steel Bracket
1	98.099	183.19

2	137.25	251.86
3	231.51	357.44
4	284.87	473.89
5	289.46	494.23
6	319.84	523.22

Table.1. Natural frequencies of GFRP and steel AC Mounting bracket

Comparison of the GFRP and steel natural frequencies shows that steel bracket has higher natural frequency when compared with the AC compressor mounting bracket designed for the same application.

FFT Analyzer is used to perform practical testing on the GFRP bracket and results are shown below graphs.

8. CONCLUSION

It can be seen that we can replace the design of steel compressor mounting bracket with GFRP material with weight saving of 52 %. First natural frequency of the AC compressor mounting bracket reduced from 183 to 98 Hz, considering maximum RPM of the compressor motor to have frequency less than 50 Hz i.e. 3000 RPM, 98 Hz is an acceptable result for the first natural frequency of the compressor mounting bracket.

FFT analyzer test is performed on the component and results are close to the simulation results with the error of 5 %.

9. REFERENCES

1. R. P. Kumar, Dr. K Rambabu, "Study of Design and Analysis of Air Conditioner Compressor Mounting Bracket". International Journal of Science and Research (IJSR) ISSN (Online): 2319-7064 Index Copernicus Value (2013): 6.14 | Impact Factor (2013): 4.438.
2. Harshal Bankar, P. Baskar, "Dynamic Analysis of Air Conditioner Compressor Mounting Bracket". International Engineering Research Journal (IERJ) Special Issue 2 Page 4825-4829, 2015, ISSN 2395-1621.
3. M. Singh • D. Singh • J. S. Saini, "Dynamic Analysis of Condenser Assembly of Automobile Air Conditioning System Using CAE Tools". J. Inst. Eng. India Ser. C (April–June 2013) 94(2):135–145 DOI 10.1007/s40032-013-0067-z.
4. Pushpendra Mahajan, Prof. Abhijit L. Dandavate, "Analysis and Optimization of Compressor Mounting Plate of Refrigerator using FEA". Website: www.ijetae.com (ISSN 2250-2459, ISO 9001:2008 Certified Journal, Volume 5, Issue 5, May 2015).
5. Vyankatesh D. Pawade, Pushkaraj D. Sonawane, "Study of Design and Analysis of Air Conditioner Compressor Mounting Bracket". International Journal of Science and Research (IJSR) ISSN (Online): 2319-7064 Index Copernicus Value (2013): 6.14 | Impact Factor (2013): 4.438.
6. Umesh S. Ghorpade, D. S. Chavan, Vinaay Patil & Mahendra Gaikwad, "Finite Element Analysis and Natural Frequency Optimization Of Engine Bracket". Mechanical Engineering Dept., Rajarambapu Institute of Technology, Sakharale, Islampur, India 3&4FEA (Finite Element Analysis) Dept., Vaftsy CAE, Pune, India
7. A. S. Adkine, V. S. Kathavate, G. P. Overikar, S. N. Doijode, "Static Behaviour of Engine Mounting Bracket". International Advanced Research Journal in Science, Engineering and Technology Vol. 2, Issue 4, April 2015.
8. Mallikarjun B Patil, Prof. S.S Kelkar, "Finite Element Analysis and Natural Frequency Optimization of Engine Mounting Bracket". International Engineering Research Journal Page No 981-989.
9. KS. Kong, "Optimization Driven Design of Compressor Mounting Bracket", APM engineering and research SDN BHD. Altair technology conference.