

POWER GENERATION FROM WASTE ENERGY SYSTEM

Akshay Gawhane¹, Sagar Adhalrao², Abhijit Umbardand³

^{1,2}Student, Dept of E&TC, DYPSOET, Maharashtra, India

³Asst. Professor, Dept of E&TC, DYPSOET, Maharashtra, India

ABSTRACT

We all know everywhere there is huge scarcity of energy and for running most of our appliances and to carry out daily work we need electricity. It is really very difficult to imagine our life without electricity, our life would really stop so there is high need to produce electricity at faster rate and find some other feasible method to produce electric energy. On the other hand we see that in this modern world there is lot of noise pollution in roads, airports, industries. Thus to convert this noise pollution into electric energy in our project we have decided to develop new method for generating electricity i.e. generates electricity form sound and from radiated light and generated energy is stored in battery .we can use this stored energy for any application like mobile charging etc.

KEYWORDS:- piezoelectric sensor, photovoltaic sensor, Arduino board, battery, mobile charging unit.

I.INTRODUCTION:-

In our project we have decided to develop new method for generating electricity i.e. generates electricity form sound and from radiated light.

A. CONVERTING SOUND ENERGY TO ELECTRIC ENERGY

Sound is a mechanical form of energy which travel in the form of wave, mechanical wave that is an oscillation of pressure this pressure created by the sound could be used to convert it into electric energy or other form of energy. Also according to law of thermodynamics mechanical energy could be converted into electricity. Piezo material converts mechanical strain into electric energy this property of piezo material could be used to make a device which would be able to sustainably convert the sound energy to electric energy as piezo material convert sound energy to electric energy. Transducer is also used to convert Mechanical energy to electric energy i.e. it can convert sound energy to electric energy the simple e.g. of use of transducer to convert sound to electric and vice versa is in speakers, headset...also it could be converted into electric energy by other methods which we will see in the paper.

B. CONVERTING RADIATED LIGHT ENERGY TO ELECTRIC ENERGY

A typical silicon PV cell is composed of a thin wafer consisting of an ultra-thin layer of phosphorus-doped (N-type) silicon on top of a thicker layer of boron-doped (P-type) silicon. An electrical field is created near the top surface of the cell where these two materials are in contact, called the P-N junction. When sunlight strikes the

surface of a PV cell, this electrical field provides momentum and direction to light-stimulated electrons, resulting in a flow of current when the solar cell is connected to an electrical load

II. DESIGN OF POWER GENERATION FROM WASTE ENERGY SYSTEM

The following are the important elements in the block diagram:-

- I. Arduino board
- II. Power supply
- III. Piezoelectric sound sensor
- IV. Photo voltaic electric sensor

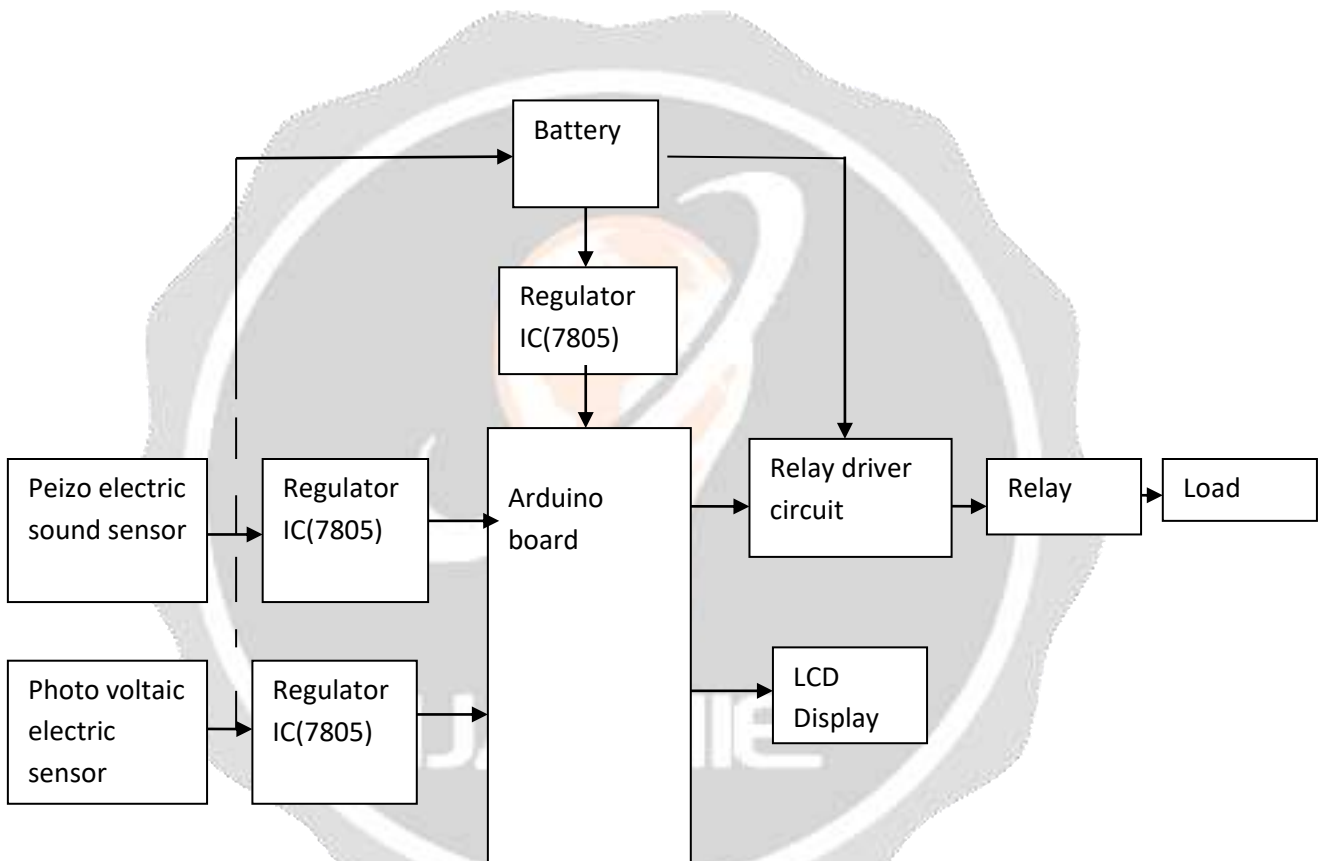

Figure - Block Diagram of Power generation from waste energy

III. WORKING:-

The photovoltaic sensor is also use to convert radiated light energy Example Street light or tube light use in homes into electrical energy. Sound energy is also converting to electric energy by using piezoelectric sensor. We are taking Piezo electric sensor having a high sensibility as compare to piezoelectric sensor use in converting pressure. So proper amount of sound or noise, radiated light and pressure is applied to respective so at output we get electric energy. At the output of these two sensor we get electric energy which is not in proper amount .So by connecting signal conditioner(IC7805) at the output of this two sensor only 5volt is given to Arduino board controller and remaining voltage which is produce by sensor is given to battery.

At the output of battery we are using IC7805 to drive the arduino board. Mainly arduino board is use only for switching purpose and also to display that which sensor is use to charge the battery or given to controller. Arduino board will drive the relay driving only when the input is applied to sensors. At the output of really driving circuit relay is use which is act as a switch. We are using single pole double through (SPDT) relay as a switch. At the output of relay we are connecting a load that means mobile. In this way we can charge our mobile from waste of energy sources.

IV. ADVANTAGES

1. Sensors used have high sensitivity and are easy to handle.
2. Low cost system, providing maximum automation.
3. Low maintenance and low power consumption.
4. The system is more compact compared to the existing ones.
5. No fuel transportation required.
6. No external source is needed for power generation.

V. APPLICATIONS

1. The noise pollution in the road would be able to convert into electric energy and lights the street lightning, signals and various other electrical appliances.
2. The noise pollution in runway could be used to produce electricity.
3. The electricity produce in nuclear power station could increase as the sound produce during nuclear fission also could be used to get more electric energy.
4. The noise pollution in industries could be used to produce electricity and work certain low voltage machine.
5. The radiated light example street light of tube light use in home is reuse by photovoltaic cell to generate electricity.

VI. CONCLUSIONS:-

The result of our project is, we are generating a electrical energy which is free of cost that means waste of energy sources is reused to generate electricity to charge our mobile. Hence by using photovoltaic and piezoelectric sensor we generate a electricity which is economically free.

VII. FUTURE SCOPE

1. These Power source can also implement in agriculture Field, home application and street lighting and as energy source for sensors in remote locations.
2. By using the multi pin charger, we can also connect more than one mobile for charging.

VIII. REFERENCES:-

- [1] Opensource.org, “www.alldatasheet4u.com,” 2011.
- [3] International Journal of Engineering and Innovative Technology (IJEIT) Volume 3, Issue 10, April 2014.
- [4] Websites (google, electronics4u,).
- [5] Home Automation Using Power Line communication- Karim Shah, Zeshan Sikandar Niazi.
- [2] Design Study of Piezoelectric Energy- Harvesting Devices for Generation of Higher Electrical Power Using a Coupled Piezoelectric-Circuit Finite Element Method IEEE Transactions on Ultrasonic's, Ferroelectrics, and Frequency Control, vol. 57, no. 2, February 2010.

