

Solar power bank with wireless charging

Jagtap Chetan Hiranman

MIT Polytechnic, Yeola

Vyavahare Om Balu

MIT Polytechnic, Yeola

Lathe Payal Ganesh

MIT Polytechnic, Yeola

Wavre Dipak Rajendra

MIT Polytechnic, Yeola

Salpure Kiran Sahebrao

MIT Polytechnic, Yeola

Abstract

The smart solar power bank integrates lithium battery pack with solar panels battery protection and wireless charging coils using dc power boosters and charge controllers to provide for a feature packed power bank. This solar panels are used with charge controller to charge the battery pack using charging circuitry. The power bank makes use of LED for indication of current battery capacity. The battery pack power is used to power the induction coil that is mounted on the top of the power bank. When mobile phone is placed over the top of the power bank an electromagnetic induction effect induces electrical current in the coil mounted in the phone back. This is used to charge the phone wirelessly.

Keywords-Solar energy, Portable, Disaster recovery, Battery ,Wireless charging, Inductive coupling

INTRODUCTION

Power banks are one of the need to have product these days. But even power banks need charging. For that one needs to get the power bank charged in a power plug. This is not always possible when travelling so here we design a smart solar powered folding power bank. The solar power bank integrates solar charging with efficient battery support and wireless charging to provide a multi functional unique power bank product. The device is able to self charge anywhere during day time so that the user never runs out of power. Wireless charging is an emerging technology now a days. Wireless charging is also known as wireless power transfer; here the power is transferred to load without interconnecting cords. In 2015 Samsung introduced wireless charging into galaxy s6 mobiles. Wireless charging is also called as inductive charging. Wireless charging mainly eliminates the cable required for charging. It reduces the wear and tear of the hardware ports. The major liability or drawbacks of communication lines comes because of the distortion of electrical lines or lack of generation of electricity as like in remote areas or during disaster or natural calamities. To set back such drawbacks, we need a renewable source of energy which can function round the clock without any disruption. Solar power bank is one of its kind. It works on the power of the sun, converting solar to electrical and helps in charging the cell phones which can be used in communication, and thus, turns to be vital during disasters and power outage. Solar energy has advantages over other renewable energy sources including wind and water power: solar power is generated using solar panels, which do not require any major mechanical parts, such as wind turbines. These mechanical parts can breakdown and cause maintenance issues and can also be quite noisy. Both of these issues are virtually non-existent with solar panels. This project aims at harvesting solar energy and storing it in a rechargeable battery. Using this battery various low-voltage device can be charged. Also, the charge in the battery is displayed on an LCD through a micro-controller.

OBJECTIVES

- 1.Solar energy as energy source.
- 2.Rechargeable battery as storage device.
- 3.Multi-voltage outputs.
- 4.Charging of various low-voltage devices.
- 5.Battery charge analyzer.
- 6.Display of critical conditions of the battery.

METHODOLOGY

The block diagram of solar mobile charger consists of solar panel with control unit, fixed voltage regulators, rechargeable battery, ADC, Schmitt trigger, micro-controller and an LCD. The solar panel of 12V, 10W is used, the output of which varies based on the intensity of incident light. This output is regulated through a control unit and is stored in a battery. This battery produces an output of 12V which can be used directly to charge the load. A 9V fixed output can be obtained by regulating the voltage from battery using an L7809 voltage regulator and can be used to charge a 9V load. The battery can be regulated further to obtain a 5V fixed output, using L7805 and charge a 5V load. The 5V output, so obtained, is also used to power-up the micro-controller, ADC, Schmitt trigger and the LCD. The Schmitt trigger is used to trigger the ADC0808 which converts the analog voltage across the battery terminals into digital. Micro-controller AT89S51 is used to display this charge on the LCD JHD0161.

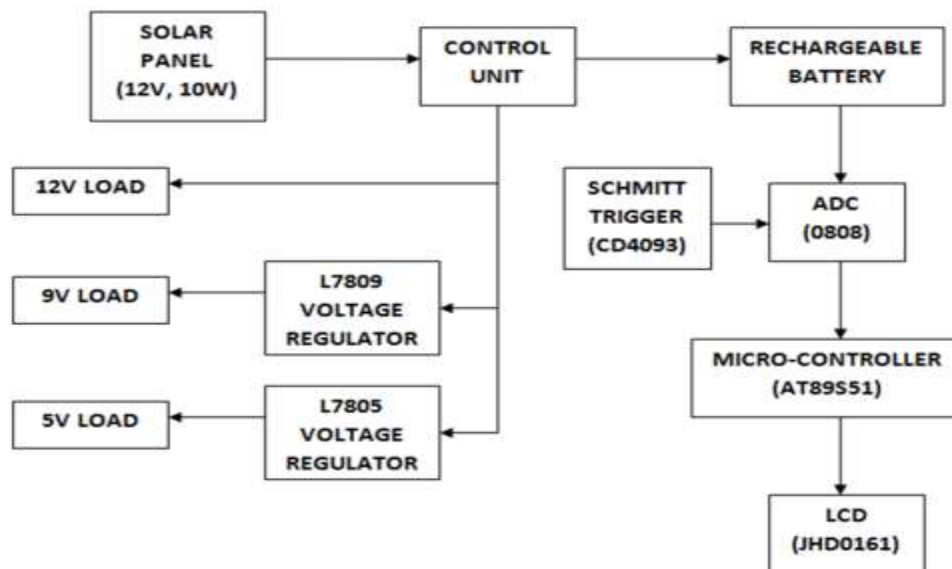

Fig .Block Diagram 1

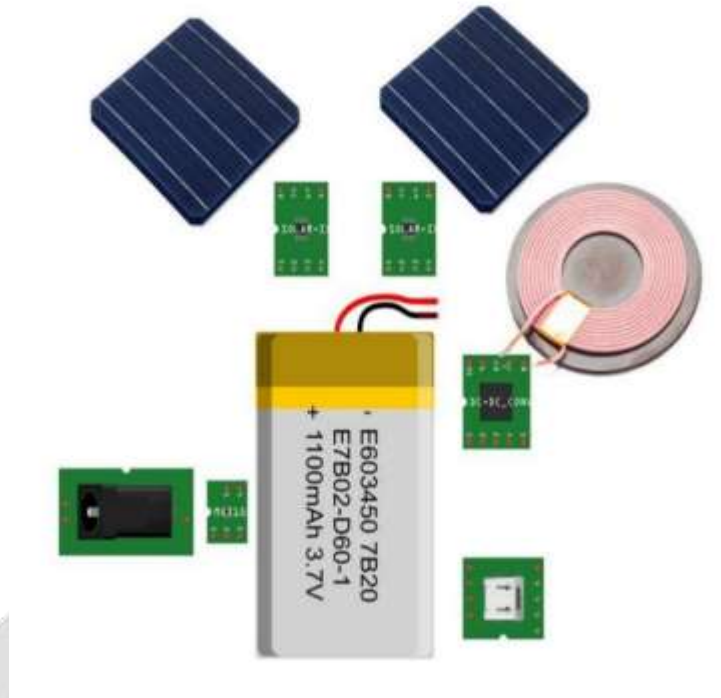

Fig.Block Diagram 2

List of components / Material required

- a. Solar Panels
- b. Charge Controller Charging Coil
- c. Battery Panel d. LED
- e. Voltage Booster IC
- f. Charging Circuitry
- g. Resistors Capacitors
- h. Diodes & transistors
- i. Buttons & Switches Electrical & Wirings
- j. PCB Board k. Coil Mounting hinges
- k. Plastic Cover m. Connectors n. Screws and Fittings

TECHNICAL FEASIBILITY

There are 2 main things to consider choosing a Solar panel or creating a Solar system. Battery capacity is measured in Amp Hours. The AH figure must be multiplied by the battery voltage to convert this to Watt Hours which is given by the simple calculation below. $(1) \diamond X \times Y = Z$ Battery size in AH \diamond where, X Battery Voltage \diamond Y Power available in watt hours \diamond Z However, as we know that we will not be able to power the battery once the voltage drops below our equipment's 150 American Journal of Electrical and Electronic Engineering requirements, that is why, we are never really able to take all the power from a battery. Lead acid batteries will give around 50% of their rated power and Li-ion batteries will give around 80% of their rated power. Solar panels are the most critical and final part in designing solar panels. The generation of power in a solar panel is measured in Watts (e.g. The power generation of part number STP010 in a solar cell is 10W). Theoretically, the energy that can be supplied to a battery can be calculated by multiplying the power generation rating of the solar panel (measured in Watts) to the number of hours the panel is exposed to sunshine. A photovoltaic module can be defined as an assembly of 6x10 solar cells connected and packaged together. The solar array of a photovoltaic system which is generally comprised of these photovoltaic cells generate solar electricity and is used in domestic applications. Under standard test conditions, the DC output power of each module ranges between 100 to 365 watts. If the rated output of a solar panel remains the same, the efficiency is determined by the area of the module i.e. a 16% efficient 230 W solar module will consume half the area as that of a 8% efficient 230W module. Only a few solar panels exceed an efficiency of over 19%.

WORKING

1. Solar panel

Solar panels convert solar energy into electricity. They use the concept of photoelectric effect, emission of electrons when light falls on solar panel. Solar panels are made up of silicon cells, silicon has an atomic number 14. When light falls on silicon cell, the outer most electrons of silicon i.e. two electrons are set into motion. This initiates the flow of electricity. Silicon has two different cell structures: monocrystalline and polycrystalline. Monocrystalline solar panels are manufactured from one large silicon block and are made in silicon wafer formats. Polycrystalline solar cells are also silicon cells, which are produced by melting multiple silicon crystals together.

2. Transmitter

Transmitter section basically consists of an a stable multi vibrator, power resistor, and inductor as shown in Fig.2. The obtained DC voltage from solar panel is converted into AC voltage using an a stable multi vibrator. A stable multi vibrator circuit is built using IC 555 timer, it is a simple oscillator circuit that produces continue square wave pulses. The frequency of the circuit can be adjusted using R1,R2 & C1. The reason for using 555 timer is that it is cheap, stable & user friendly.

3. Batteries

Lithium ion battery is rechargeable battery. During discharging lithium ions moves from negative electrode to the positive electrode, during charging lithium ions move from negative electrode to positive electrode. Electrolyte provides conductive medium for lithium ions to move from positive electrodes to negative electrodes.

4. Voltage regulator

The function of the voltage regulator is to maintain the constant voltage across any device Voltage. The voltage regulator used in this receiver coil is IC LM7805. it provides a constant voltage of +5 volts. The input voltage range is 7v – 5v. current rating IC=1A. the output voltage range is from 4.8v -5.2v.

Applications

1. To charge mobile phone and camera (digital as well as CC cameras).
2. MP3, CD and MD players can be charged.
3. This device can also be used to charge batteries of portable DVD, smart card readers, etc.
4. To charge laptop, I-pods, tablets, blue-tooth devices etc.
5. To power 2W bulbs in hut, bed-lamps, low-watt lights, etc.

FUTURE SCOPE

1. Solar energy can only be harnessed when it is daytime and sunny. To overcome this, solar panels can be coupled with back-up battery which can store the excess power generated during the day and use it to provide energy to system in the absence of sunlight.
2. The Lead-acid battery used in the design is large in size and heavy in weight which makes the device non-portable. Hence a battery of pocket size and optimal weight may be designed to make the device portable.
3. The large size of the solar panel makes the device bulky and non-portable. The solar panel should be fabricated to cover the entire device, which can effectively reduce the size of the entire device.

CONCLUSION

Solar act as good power supplies in bright sunlight. The only problem is the unregulated voltage due to the variation in intensity of light. Voltage regulator is used to solve this problem by regulating the output voltage. The charge so obtained is stored in the battery and is given to the respective loads. The charge present in this battery is analyzed and displayed on an LCD using a micro-controller.

REFERENCES

- [1] Ahmed A. S. Mohammed, Dueal Allen, Osama Mohamed and Tarek Yousef S “Optimal Design of High Frequency HBridge Inverter for Wireless Power Transfer Systems in EV ” in 2016 IEEE/ACES International

Conference on Wireless Information Technology and Systems (ICWITS) and Applied Computational Electromagnetics.

[2] Xiao Luy, Ping Wangz, Dusit Niyatoz, Dong In Kimx, and Zhu Han “Wireless Charging Technologies: Fundamentals, Standards, and Network Applications”

[3] L. Olvitz, D. Vinko and T. Svedek “Wireless Power Transfer for Mobile Phone Charging Device” in MIPRO 2012, May 21-25,2012, Opatija, Croatia.

[4] Harshal Sharma “Study & Survey on Wireless Charging Technology” in International Journal of Engineering Science & Research Technologies.

[5] How solar panel works (<https://www.evoenergy.co.uk/technology/how-solar-panelswork/>).

[6] Lithium-ion battery (https://en.wikipedia.org/wiki/Lithiumion_battery).

